

**Working Paper Series**

**PROVIDE**  
**PROJECT**  
The Provincial Decision-making Enabling Project

**Working Paper 2006:3**

**The impact of an increase in  
wine industry exports on the  
SA economy, focusing on the  
Western Cape**

*Eisenburg*  
*November 2006*

# PROVIDE

# PROJECT

The Provincial Decision-making Enabling Project

## Overview





The Provincial Decision-Making Enabling (PROVIDE) Project aims to facilitate policy design by supplying policymakers with provincial and national level quantitative policy information. The project entails the development of a series of databases (in the format of Social Accounting Matrices) for use in Computable General Equilibrium models.

The National and Provincial Departments of Agriculture are the stakeholders and funders of the PROVIDE Project. The research team is located at Elsenburg in the Western Cape.

## PROVIDE Research Team

|                        |                               |
|------------------------|-------------------------------|
| Project Leader:        | Cecilia Punt                  |
| Senior Researchers:    | Kalie Pauw<br>Melt van Schoor |
| Young Professional:    | Bonani Nyhodo                 |
| Technical Expert:      | Scott McDonald                |
| Associate Researchers: | Lindsay Chant                 |

## PROVIDE Contact Details

|   |  |
|---|--|
|  | Private Bag X1<br>Elsenburg, 7607<br>South Africa                |
|  | <a href="mailto:provide@elsenburg.com">provide@elsenburg.com</a> |
|  | +27-21-8085191   |
|  | +27-21-8085210   |

For the original project proposal and a more detailed description of the project, please visit [www.elsenburg.com/provide](http://www.elsenburg.com/provide)

# The impact of an increase in wine industry exports on the South African economy, focusing on the Western Cape<sup>1</sup>

## Abstract

*A marketing strategy undertaken by role players in the wine industry is expected to lead to increases in South African wine exports. A multi-sector analysis, which takes into account the linkage effects in an economy, was conducted to estimate the impact of an increase in wine exports on the South African economy. The increase in wine exports will be the result of changed perceptions and hence increases in the export price faced by South African wine producers. Results of a 10% increase in the international wine price indicated an increase of 0.1% in gross domestic product (GDP). The general positive effect on the economy is reflected by the creation of 5 824 employment opportunities, of which 20% is in the Western Cape. Factor incomes shows varied results, but are positive for all five labour groups identified in the Western Cape (increase between 0.11 and 0.16%). Domestic production of wine increases by 4.5%, while the volume of exports increases by 26.7% and domestic sales volume by 1.45%. When comparing long-run and short-run results it becomes evident that capital might be a binding constraint over the short-run, but seen in the light that in practice the increase in the international price will not happen overnight, this becomes less of an obstacle. A successful marketing strategy is likely to cause additional investment in the industry.*

---

<sup>1</sup> The main authors of this paper are Scott McDonald, Cecilia Punt and Siphon Bhanisi (Junior Economist, Western Cape Department of Agriculture).

**Table of contents**

|  |            |
|--|------------|
| <b>Executive Summary</b> .....   | <b>iii</b> |
| <b>1. Introduction</b> .....   | <b>1</b>   |
| <b>2. International trade and the SA wine industry</b> .....                     | <b>1</b>   |
| <b>3. Computable general equilibrium model and data</b> .....                    | <b>3</b>   |
| 3.1. CGE model .....   | 3          |
| Behavioural relationships .....  | 4          |
| Price and quantity relationships.....  | 7          |
| 3.2. Data (Social Accounting Matrix) .....                                       | 9          |
| <b>4. Policy scenarios</b> .....   | <b>10</b>  |
| 4.1. Scenarios.....  | 10         |
| 4.2. Closure rules .....   | 10         |
| <b>5. Model results</b> .....  | <b>12</b>  |
| 5.1. Impact on selected macroeconomic indicators .....                           | 12         |
| 5.2. Impact on the wine industry .....   | 13         |
| 5.3. Impact on factor employment and income .....                                | 14         |
| 5.4. Impact on households welfare and consumption.....                           | 16         |
| 5.5. Impact on prices.....   | 19         |
| 5.6. Impacts in the short-run .....  | 20         |
| <b>6. Conclusion</b> .....   | <b>21</b>  |
| <b>7. References</b> .....   | <b>23</b>  |
| <b>8. Appendices</b> .....   | <b>24</b>  |
| 8.1. Appendix A: SAM Accounts.....   | 24         |
| 8.2. Appendix B: Classification of occupations into skill level categories ..... | 26         |

**List of Figures**

|   |    |
|---|----|
| Figure 1: Exports and imports of natural wine (million litres).....   | 2  |
| Figure 2: Price relationships for a standard model with commodity exports .....   | 8  |
| Figure 3: Quantity relationships for a standard model .....   | 9  |
| Figure 4: Impact on selected macroeconomic variables for a 10% increase in the international wine price .....                     | 13 |
| Figure 5: Change in production and trade volumes of wine for a 10% increase in the international wine price .....                 | 14 |
| Figure 6: Number of jobs created for a 10% increase in international wine prices .....  | 15 |
| Figure 7: Changes in incomes of labour in the Western Cape for a 10% increase in international wine prices.....                   | 16 |
| Figure 8: Changes in incomes of households in the Western Cape for a 10% increase in international wine prices.....               | 17 |
| Figure 9: Changes in household welfare for a 10% increase in international wine prices .....                                      | 18 |
| Figure 10: Changes in domestic demand for agricultural and food commodities for a 10% increase in international wine prices ..... | 19 |
| Figure 11: Changes in the consumer prices (PQD) of selected commodities for a 10% increase in international price of wine.....    | 20 |

**List of Tables**

|   |    |
|---|----|
| Table 1: Relationships for the computable general equilibrium model.....  | 6  |
| Table 2: Changes in wine production and trade volumes for the long-run and short-run closure for a 10% increase in the international wine price ..... | 20 |

## Executive Summary

A marketing strategy undertaken by role players in the wine industry is expected to lead to an increase in South African wine exports, because of a perception that the quality of South African wines has increased. A multi-sector analysis, which takes into account the linkage effects in an economy, was conducted to estimate the impact of an increase in wine exports on the South African economy. In the long run the international demand for South African wine will be determined by consumer perceptions about the South African product and its price relative to competitors. If the international demand for South African wine expands then the export price should increase relative to the price received by international competitors, and, in terms of the model, the domestic market price; assuming that the domestic market perception does not increase as much as the international perception. In the context of a relative price based Computable General Equilibrium model, this would manifest as an increase in the export price of South African wine.

Results of a 10% increase in the international wine price indicated an increase of 0.1% in gross domestic product (GDP). The exchange rate shows a depreciation of 0.02%, while the value of total exports and imports for South Africa both increase by approximately 0.14%. The increase in imports is stimulated by a net increase in factor incomes and hence expendable household incomes. The general positive effect on the economy is also reflected by the creation of 5 824 employment opportunities, of which 20% are in the Western Cape. Factor incomes show varied results with changes ranging between 0.76% and -0.57% for labour groups throughout South Africa. Factor incomes increase for all five labour groups identified in the Western Cape (increase between 0.11% and 0.16%). Expendable household incomes show similar trends.

Although aggregate expenditures by households tend to increase, consumption of individual products show both increases and decreases in demand depending on movements in commodity prices of individual products. The purchaser price of wine decreases by 1.47% and domestic consumption increases by 1.45%. This increase in demand is the result of an expansion and price effect. In order to meet the increase in domestic demand, as well as the increase of 26.7% in the volume of exports, domestic production of wine increases by 4.5%. The volume of wine imports decline by 1.73%.

Comparing long-run and short-run results it becomes evident that capital might be a binding constraint over the short-run, but seen in the light that in practice the increase in the international price will not happen overnight, this becomes less of an obstacle. A successful marketing strategy, which leads to sustained increases in the international price of South

African wine, is however likely to require additional investment in the industry in order for the industry to expand sufficiently to reap the benefits of the increase in export demand.

## **1. Introduction**

South Africa has excellent climatic conditions for wine production, and consequently, the country has a history of wine production that dates back to 1655. The latest significant development in this long history has been the opening up of new foreign markets after the end of sanctions, imposed by the international community, following democratic elections held in South Africa in 1994. The South African Wine Industry Council developed a marketing strategy targeted at international markets. The aim of this paper is to discuss the potential socio-economic impacts of increases in global exports of South African wine.

This paper is structured as follows: Section 2 gives an overview of the South African wine industry within a global context. An overview of the model and data used in this study is presented in section 3, while section 4 relates to the various scenarios simulated and the model closure rules. The results are discussed in section 5 and conclusions follow in section 6.

## **2. International trade and the SA wine industry**

The value of fortified, sparkling and natural wine exports in 2005 amounted to R3 810 million, with natural wine accounting for 97.7% (SARS, 2005). Wine exports as a percentage of domestic sales grew from 13.8% to 81.6% from 1994 to 2005, with the total quantity of wine exported increasing by 456% in the same period, from 50.7 million litres to 281.81 million litres (see Figure 1), despite the strengthening of the Rand against most major currencies in the last couple of years. This positive trend in export growth has managed to offset the somewhat sluggish domestic sales, which have dropped by 5.5% from 365.4 million litres in 1994 to 345.1 million litres in 2005 (SAWIS, 2006).

The value of fortified, sparkling and natural wine imports in 2005 amounted to R107 million, with natural wine accounting for 44.4% (SARS, 2005). Wine imports have increased from 0.48 million litres in 1994 to 18.15 million litres in 2005, peaking at 46.4 million litres in 2003 (SAWIS, 2006). As can be seen from Figure 1, this growth has occurred through very cyclical movements. The integration of South Africa into the global economy and its WTO membership necessitated an opening up of the local market by reducing protection, mainly through tariff reductions to levels that are in line with WTO requirements. This has exposed the local industry to increased foreign competition, although it has simultaneously provided the South African consumer with access to a greater variety of products.

**Figure 1: Exports and imports of natural wine (million litres)**

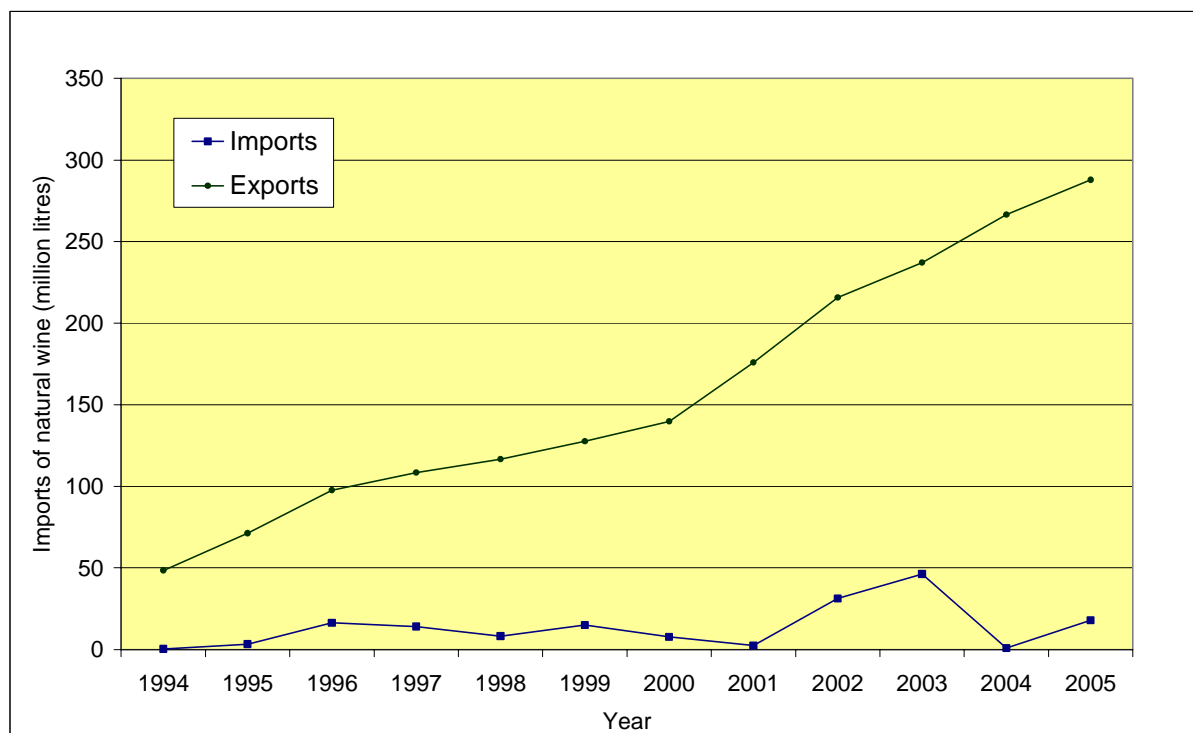

Source: SAWIS (2006) Tables 8.1 and 9.1.

The UK was the biggest foreign consumer of South African wine in 2005, with 32.4% of the value of wine exports destined for the UK, followed by the Netherlands at 12.8% (SARS, 2005). Almost all foreign markets of South African wine showed major growth from 2003 to 2004, with Norway growing the fastest, followed by the South American market, although its recorded growth was from a low base.

In contrast with the domestic market, red wine seems to be more popular with foreign consumers of South African wine, as exports of red wine edged those of white wine in 2004. The growing importance of the foreign market to domestic producers is noticeable, as the land planted to red grape varieties increased from 21.9% to 46% as a percentage of the total land under wine grape plantation, from 1997 to 2004. Also red grapes as a percentage of total grapes utilised for wine making purposes grew from 11.6% to 29.9% in the same period (SAWIS, 2006).

The sluggish domestic wine sales seem to be part of a general decline in the domestic demand for alcoholic beverages. Industry statistics show a poor performance by other alcoholic beverages, such as spirits (brandy, wine spirits, cane spirits and grain spirits), which had a 16.7% drop in domestic sales from 37.6 million litres to 31.3 million litres, from 1994 to 2004. This contraction of the local market, despite the general increase in the income of an average South African, is partly attributable to the rise in domestic prices associated with the

increase in sales to overseas markets. However, the dramatic annual increases in excise tax on wines, ciders and spirits by National Treasury, which increased by 91% for fortified wine and by 130% for sparkling and natural wine between March 1998 and February 2005 (SAWIS, 2006), may also have contributed to reductions in domestic demand.

The South African wine industry still has good growth prospects within the local market, as wine only had a 14.3% market share in the alcoholic beverages market, which is dominated by beer, whose market share was 43% in 2005. A growing middle class market seems the most likely source of growth for domestic sales. The greatest growth potential however, for the local wine industry seems to be the foreign market. Since South Africa produced only 3.3% of world wine in 2003, it appears reasonable to expect considerable growth prospects.

The aim of the marketing strategy is to increase market penetration. If the marketing strategy is successful then the anticipated increase in exports could come from a combination of sources. There is capacity, although limited, to increase the area under vineyards, but this would most likely imply that land must be diverted from another enterprise, with a trade-off effect. In the CGE model the amount of land per agronomic region is assumed fixed and the use pattern of that land remains unaltered. The effect of an increase in the area under vineyards is therefore not taken into account. There is however an implicit assumption that the productivity with which the land is used in combination with other factors of production increases, enabling an increase in total production volumes. Higher yields as a result of improved technology are also a viable source of increased exports, but this source was not explored in the simulations. Another likely source of export increases, which is reflected in the CGE model results, is that a relatively greater share of production will be directed towards the export market as opposed to the domestic market as the export market becomes relatively more profitable.

### **3. Computable general equilibrium model and data**

#### **3.1. CGE model**

The computable general equilibrium (CGE) model (see PROVIDE, 2005) is a member of the class of single country computable general equilibrium (CGE) models that are descendants of the approach to CGE modeling described by Dervis *et al.*, (1982). More specifically, the implementation of this model, using the GAMS (General Algebraic Modeling System) software, is a direct descendant and development of models devised in the late 1980s and early 1990s, particularly those models reported by Robinson *et al.*, (1990), Kilkenny (1991) and Devarajan *et al.*, (1994). The model is a SAM based CGE model, wherein the SAM serves to identify the agents in the economy and provides the database with which the model is calibrated. The SAM also serves an important organisational role since the groups of agents

identified by the SAM structure are also used to define sub-matrices of the SAM for which behavioural relationships need to be defined. As such the modelling approach has been influenced by Pyatt's 'SAM Approach to Modeling' (Pyatt, 1988).

The description of the model here is necessarily brief and proceeds in two stages. The first stage is the identification of the behavioural relationships; these are defined by reference to the sub matrices of the SAM within which the associated transactions are recorded. The second stage uses a pair of figures to explain the nature of the price and quantity systems for commodity and activity accounts that are embodied within the model.

### *Behavioural relationships*

While the accounts of the SAM determine the agents that can be included within the model, and the transactions recorded in the SAM identify the transactions that took place, the model is defined by the behavioural relationships. The behavioural relationships in this model are a mix of non-linear and linear relationships that govern how the model's agents will respond to exogenously determined changes in the model's parameters and/or variables. **Table 1** summarises the model relationships by reference to the sub matrices of the SAM.

Households are assumed to choose the bundles of commodities they consume so as to maximise utility where the utility functions are Stone-Geary functions that allow for subsistence consumption expenditures, which is an arguably realistic assumption when there are substantial numbers of very poor consumers. The households choose their consumption bundles from a set of 'composite' commodities that are aggregates of domestically produced and imported commodities. These 'composite' commodities are formed as Constant Elasticity of Substitution (CES) aggregates that embody the presumption that domestically produced and imported commodities are imperfect substitutes. The optimal ratios of imported and domestic commodities are determined by the relative prices of the imported and domestic commodities. This is the so-called Armington assumption (Armington, 1969), which allows for product differentiation via the assumption of imperfect substitution (see Devarajan *et al.*, 1994). The assumption has the advantage of rendering the model practical by avoiding the extreme specialisation and price fluctuations associated with other trade assumptions. In this model South Africa is assumed to be a price taker for all imported commodities.

Domestic production uses a two-stage production process. In the first stage aggregate intermediate and aggregate primary inputs are combined using CES technology. Hence aggregate intermediate and primary input demands vary with the relative prices of aggregate intermediate and primary inputs. At the second stage intermediate inputs are used in fixed proportions relative to the aggregate intermediate input used by each activity. The 'residual' prices per unit of output after paying for intermediate inputs, the so-called value added prices,

are the amounts available for the payment of primary inputs. Primary inputs are combined to form aggregate value added using CES technologies, with the optimal ratios of primary inputs being determined by relative factor prices. The activities are defined as multi-product activities with the assumption that the proportionate combinations of commodity outputs produced by each activity/industry remain constant; hence for any given vector of commodities demanded there is a unique vector of activity outputs that must be produced. The vector of commodities demanded is determined by the domestic demand for domestically produced commodities and export demand for domestically produced commodities. Using the assumption of imperfect transformation between domestic demand and export demand, in the form of a Constant Elasticity of Transformation (CET) function, the optimal distribution of domestically produced commodities between the domestic and export markets is determined by the relative prices on the alternative markets. The model can be specified as a small country, i.e., price taker, on all export markets, or selected export commodities can be deemed to face downward sloping export demand functions, i.e., a large country assumption. The other behavioural relationships in the model are generally linear.

**Table 1: Relationships for the computable general equilibrium model**

|                      | Commodities   | Activities                                       | Factors  | Households                            | Enterprises                       | Government                           | Capital                 | RoW                        | Total  | Prices                                      |
|----------------------|---|--|--|---------------------------------------|-----------------------------------|--------------------------------------|-------------------------|----------------------------|--|---|
| <b>Commodities</b>   | 0   | Leontief Input-Output Coefficients               | 0  | Utility Functions (Stone-Geary or CD) | Fixed in Real Terms               | Fixed in Real Terms and Export Taxes | Fixed Shares of Savings | Commodity Exports (CET)    | Commodity Demand   | Consumer Commodity Price Prices for Exports |
| <b>Activities</b>    | Domestic Production   | 0  | 0  | 0                                     | 0                                 | 0                                    | 0                       | 0                          | Constant Elasticity of Substitution Production Functions | Factor Income                               |
| <b>Factors</b>       | 0   | Factor Demands (CES)                             | 0  | 0                                     | 0                                 | 0                                    | 0                       | Factor Income from RoW     | Household Income   | Enterprise Income                           |
| <b>Households</b>    | 0   | 0  | Fixed Shares of Factor Income  | Fixed (Real) Transfers                | Fixed (Real) Transfers            | Fixed (Real) Transfers               | 0                       | Remittances                | Government Income  | Total Savings                               |
| <b>Enterprises</b>   | 0   | 0  | Fixed Shares of Factor Income  | 0                                     | 0                                 | Fixed (Real) Transfers               | 0                       | Net Transfers              | Current Account 'Deficit'                                | Total 'Expenditure' Abroad                  |
| <b>Government</b>    | Tariff Revenue<br>Export Taxes<br>Commodity Taxes               | Indirect Taxes on Activities<br>Factor Use Taxes | Factor Income Taxes<br>Fixed Shares of Factor Income<br>Depreciation | Direct Taxes on Household Income      | Direct Taxes on Enterprise Income | 0                                    | 0                       | Net Transfers              | Government Income  |   |
| <b>Capital</b>       | 0   | 0  | 0  | Household Savings                     | Enterprise Savings                | Government Savings (Residual)        | 0                       | 0                          | 0  |   |
| <b>Rest of World</b> | Commodity Imports   | 0  | Fixed Shares of Factor Income  | 0                                     | 0                                 | 0                                    | 0                       | 0                          |  |   |
| <b>Total</b>         | Commodity Supply (Armington CES)                                | Activity Input                                   | Factor Expenditure   | Household Expenditure                 | Enterprise Expenditure            | Government Expenditure               | Total Investment        | Total 'Income' from Abroad |  |   |
|                      | Producer Commodity Prices Domestic and World Prices for Imports | Value Added Prices                               |  |                                       |                                   |                                      |                         |                            |  |   |

The model is set up with a range of flexible closure rules. The specific choices about closure rules used in this study are defined in the Policy Analysis section below.

### *Price and quantity relationships*

**Figure 2** and **3** provide an overview of the interrelationships between the prices and quantities. The supply prices of the composite commodities ( $PQS_c$ ) are defined as the weighted averages of the domestically produced commodities that are consumed domestically ( $PD_c$ ) and the domestic prices of imported commodities ( $PM_c$ ), which are defined as the products of the world prices of commodities ( $PWM_c$ ) and the exchange rate ( $ER$ ) uplifted by *ad valorem* import duties ( $tm_c$ ). These weights are updated in the model through first order conditions for optima. The supply prices exclude sales, excise and fuel taxes, and hence must be uplifted by (*ad valorem*) sales taxes ( $ts_c$ ), excise taxes ( $tex_c$ ) and fuel taxes ( $tfue_c$ ) to reflect the composite consumer price ( $PQD_c$ ). The producer prices of commodities ( $PXC_c$ ) are similarly defined as the weighted averages of the prices received for domestically produced commodities sold on domestic and export ( $PE_c$ ) markets; the weights are updated in the model through first order conditions for optima. The prices received on the export market are defined as the products of the world price of exports ( $PWE_c$ ) and the exchange rate ( $ER$ ) less any exports duties due, which are defined by *ad valorem* export duty rates ( $te_c$ ).

The average price per unit of output received by an activity ( $PX_a$ ) is defined as the weighted average of the domestic producer prices, where the weights are constant. After paying indirect/production/output taxes ( $tx_a$ ), this is divided between payments to aggregate value added ( $PVA_a$ ), i.e., the amount available to pay primary inputs, and aggregate intermediate inputs ( $PINT_a$ ). The factor prices paid by activities ( $WF_{f,a}$ ) constitute the components of value added, while total payments for intermediate inputs per unit of aggregate intermediate input are defined as the weighted sums of the prices of the inputs ( $PQD_c$ ).

**Figure 2: Price relationships for a standard model with commodity exports**

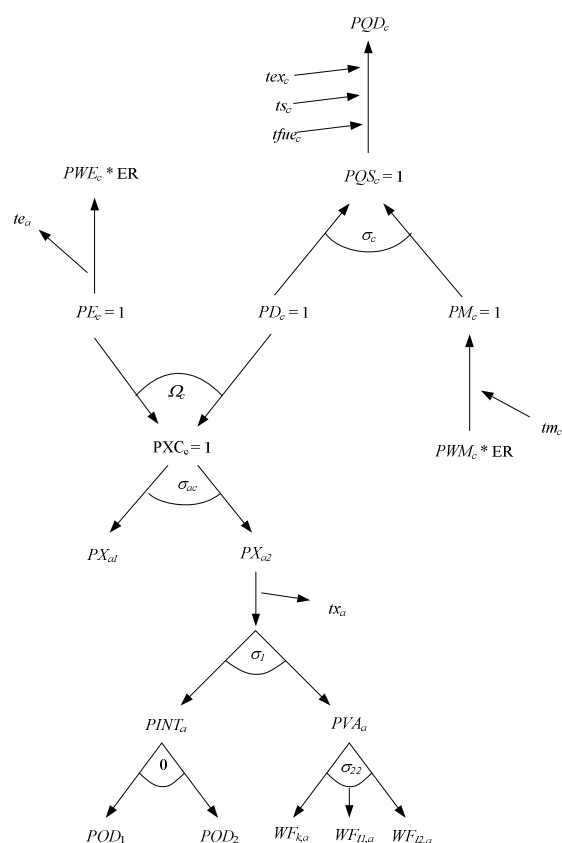

Total demands for the composite commodities,  $QQ_c$ , consist of demands for intermediate inputs,  $QINTD_c$ , consumption by households,  $QCD_c$ , enterprises,  $QENTD_c$ , and government,  $QGD_c$ , gross fixed capital formation,  $QINVD_c$ , and stock changes,  $dstocconst_c$ . Supplies from domestic producers,  $QD_c$ , plus imports,  $QM_c$ , meet these demands; equilibrium conditions ensure that the total supplies and demands for all composite commodities equate. Commodities are delivered to both the domestic and export,  $QE_c$ , markets subject to equilibrium conditions that require all domestic commodity production,  $QXC_c$ , to be either domestically consumed or exported.

The multi-product activities are modelled using the assumption that commodities are differentiated by (source) activity but that activities produce outputs in fixed proportions.<sup>2</sup> Hence the domestic production of a commodity ( $QXC_c$ ) is a CES aggregate of the quantities of that commodity produced by a number of different activities ( $QXAC_{a,c}$ ), which are produced by each activity in activity specific fixed proportions, i.e., the output of  $QXAC_{a,c}$  is a Leontief (fixed proportions) aggregate of the output of each activity ( $QX_a$ ).

<sup>2</sup> The model allows for the imposition of the alternative assumption that the ‘same’ commodities produced by different activities are homogenous.

**Figure 3: Quantity relationships for a standard model**

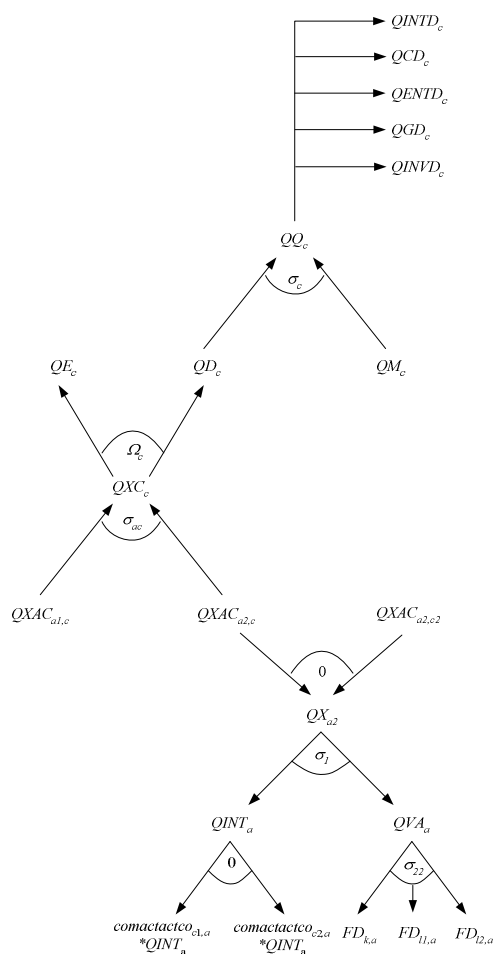

Production relationships by activities are defined by a series of nested Constant Elasticity of Substitution (CES) production functions. The nesting structure is illustrated in lower part of Figure 3, where, for illustration purposes only, two intermediate inputs and three primary inputs ( $FD_{k,a}$ ,  $FD_{11,a}$  and  $FD_{12,a}$ ) are identified. Activity output is a CES aggregate of the quantities of aggregate intermediate inputs ( $QINT_a$ ) and value added ( $QVA_a$ ), while aggregate intermediate inputs are a Leontief aggregate of the (individual) intermediate inputs and aggregate value added is a CES aggregate of the quantities of primary inputs demanded by each activity ( $FD_{f,a}$ ). The allocation of the finite supplies of factors ( $FS_f$ ) between competing activities depends upon relative factor prices via first order conditions for optima. While the base model contains the assumption that all factors are fully employed and mobile this assumption can be relaxed.

### 3.2. Data (Social Accounting Matrix)

The benchmark data are arranged in the form of a social accounting matrix (SAM), which is a system of accounts recording all transactions between agents in the economy. The SAM used for this paper is a 139 account aggregation of the PROVIDE SAM for South Africa in 2000

(See PROVIDE 2006 for a full description of the South Africa SAM database). The SAM has 10 agricultural commodities, 19 non-agricultural commodities, 9 agricultural activities, 19 non-agricultural activities, 41 factors (including capital (GOS), 9 land and 31 labour factors) and 32 households. There are also accounts for enterprise, government, capital, stock changes and the rest of the world. It should be noted that alcoholic beverages, which includes wine, are combined with soft drinks and tobacco in one account in the SAM. A full listing of the accounts can be viewed in Appendix A.

The SAM uses a supply and use structure that allows for the possibility that activities can produce multiple products, which is the case for all activities in this SAM. In other words, each agricultural activity can produce a range of commodities, which is consistent with the fact that farms are typically multi-product firms. For this study agricultural activities are defined according to provinces. Both factors and households are disaggregated according to provinces. In addition, labour factors are distinguished according to race and the level of skill of the occupation; and households are distinguished according to race and level of education of the head of the household.

#### **4. Policy scenarios**

##### **4.1. Scenarios**

Price incentives play a major role when South African wine producers make long term production and marketing decisions. Changes in international prices of wine have the effect of either stimulating or dampening exports. It is expected that a successful international marketing strategy would have the effect of increasing the export prices for South African wines. In the long-run the international demand for South African wine will be determined by consumer perceptions about the quality of South African wine and its price relative to competitors on the international market. If the international demand for South African wine increases then the export price would increase relative to the prices received by South Africa's international competitors and, in terms of the model, relative to the domestic market price; this assumes that the domestic market perception does not increase as much as the international perception. In the context of a (relative price based) CGE model, this would be manifested as an increase in the export price. For these scenarios we investigate how increases in the international price of wine of up to 25%, in five percentage point steps, would impact on the South African economy.

##### **4.2. Closure rules**

The model closure rules were selected with the objective of providing a realistic representation of the South African economy.

The *foreign exchange market* is assumed to clear via a flexible exchange rate and therefore the external balance (or current account balance) remains fixed. Since South Africa is a small country it is a price taker on international markets, i.e. all prices of imported and exported goods are fixed in foreign units.

The *capital account*, which records all savings and investment related transactions, is closed by assuming that the share of investment expenditure in total final domestic demand remains constant. This allows for some variation in the volume of investment due to changes in the prices of investment goods and from any change in the total value of domestic absorption. The equilibrating variables are the savings rates of all households and incorporated business enterprises. These rates are allowed to vary equiproportionately, which ensures that savings equal investments in the economy.<sup>3</sup>

The *factor market* closure involves different treatments for different factors. Agricultural land per province is assumed fully employed, fixed and immobile. Labour is divided into ‘semi- and unskilled’ and skilled labour for all racial groups, based on the occupation of workers<sup>4</sup>. The supply of semi- and unskilled African, Asian and Coloured labour is assumed to be perfectly elastic, based on the assumption that there is excess capacity (unemployment) of this labour in the economy. Activities can increase employment of these workers provided they are willing to pay the constant wage. Skilled labour for all racial groups, as well as the single white labour category for each province, is assumed fixed, fully employed and mobile.

The assumptions for physical capital differentiate between a short-run and a long-run approach. In the short run, physical capital is assumed fixed, fully employed and immobile, meaning that the quantity of capital used by each activity is fixed; forcing industry-specific returns to capital to adjust. In the long run however, physical capital is mobile across sectors (activities) in the economy, leading to another round of adjustments in employment.

The *government account* is closed by assuming an “inert” policy response – tax rates and the volume of government consumption are left unchanged, leaving government savings (the fiscal deficit) to vary to reach fiscal balance<sup>5</sup>.

Finally, the CPI is fixed to provide the model *numéraire*, that is, price changes are not absolute changes but have to be interpreted relative to the CPI.

In summary, two different closures were investigated for the range of changes in the world price of wine, short run and long run.

---

<sup>3</sup> A savings driven closure was also explored, but differences are negligible.

<sup>4</sup> See Appendix B for classification of occupations into skill level categories.

<sup>5</sup> The assumption that the government deficit remains fixed while consumption is allowed to change was also explored, but differences in results generated with the two closures are negligible.

## 5. Model results

The results presented focus on the long-run closure, which assumes that capital is mobile between industries, with a brief discussion of the results from the short-run closures (capital is immobile) that explores the adjustment effects, at the end of section 5. The results discussed here assume a 10% increase in international wine prices faced by South African producers. The macro-economic impacts and the impacts on the wine industry, factors, households and prices are discussed. It should be noted that alcoholic beverages, which includes wine, are combined with soft drinks and tobacco in one account in the SAM. The account 'beverages and tobacco' is therefore targeted in the experiments, implying that the shocks are applied to the beverages and tobacco industry as a whole, and not only to wine. The results should therefore be regarded as upper bound.

### 5.1. Impact on selected macroeconomic indicators

An increase in the export price of South African wine will provide South African wine producers with an incentive to increase exports relative to domestic sales. A 10% increase in the international wine price of South African wine relative to its competitors will lead to an increase of 0.1% in gross domestic product (GDP) and is indicative of a generally positive impact on the South African economy. The 0.1% increase in GDP should be placed in perspective by noting that the contribution of the beverage and tobacco industry to national GDP is approximately 1.26% as portrayed by the Social Accounting Matrix (SAM) for 2000.

For the long run scenario the exchange rate shows a depreciation of 0.02%. *A priori* one would expect the exchange rate to appreciate when exports increase. However, because capital is assumed to be mobile between industries in the long run, changes in investment can take place. For most of the factors of production the returns to those factors are greater when capital is allowed to relocate. This leads to a net increase in factor and household incomes and subsequently an increase in demand for imports. It can be shown that the consumption patterns of the households who benefit most from the expansion of the South African wine industry have a relatively large import content, hence stimulating imports. The nominal value of total exports and imports therefore both increase by approximately 0.14%, but the increase in exports is marginally greater than the increase in imports. Measured in real values there is a marginal decrease in exports, indicating the net increase in export prices. Figure 4 shows these effects on the selected macroeconomic variables.

**Figure 4: Impact on selected macroeconomic variables for a 10% increase in the international wine price**

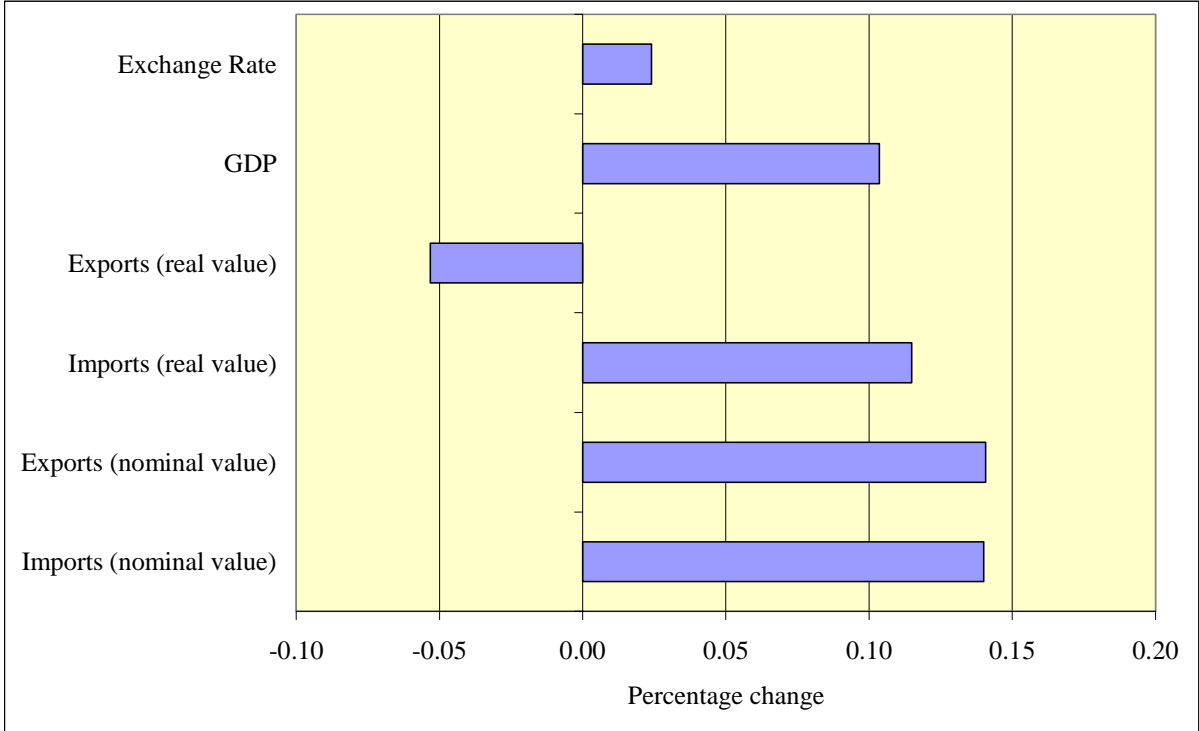

5.2. Impact on the wine industry

Figure 5 shows the impacts on the production and trade volumes of wine. The volume of wine exports increases by 26.7% for a 10% increase in international wine price. The industry will expand to supply the increase in the demand for exports, but, because not all the additional production will be exported, wine production for the domestic market increases by 1.45%. The net effect on the volume of production of wine is an increase of 4.5%. Wine imports decline by 1.73%; this is the result of an increase in the price of imported wine relative to domestically produced wine caused by the depreciation of the exchange rate. Also, the net positive impact (increase in GDP) of the expansion of the wine industry, leads to an increase in domestic demand for domestically produced wines. Note that the export volume of beverages and tobacco is only 13% of domestic production, while the import volume is 6% of domestic production.

The changes in the volumes of exports of other products range between an increase of 1.16% and a decrease of 1.89%, while that for imports range between an increase of 2.65% and a decrease of 0.96%. The range for the volume of production for other products is between +0.6% and -0.78%.

**Figure 5: Change in production and trade volumes of wine for a 10% increase in the international wine price**

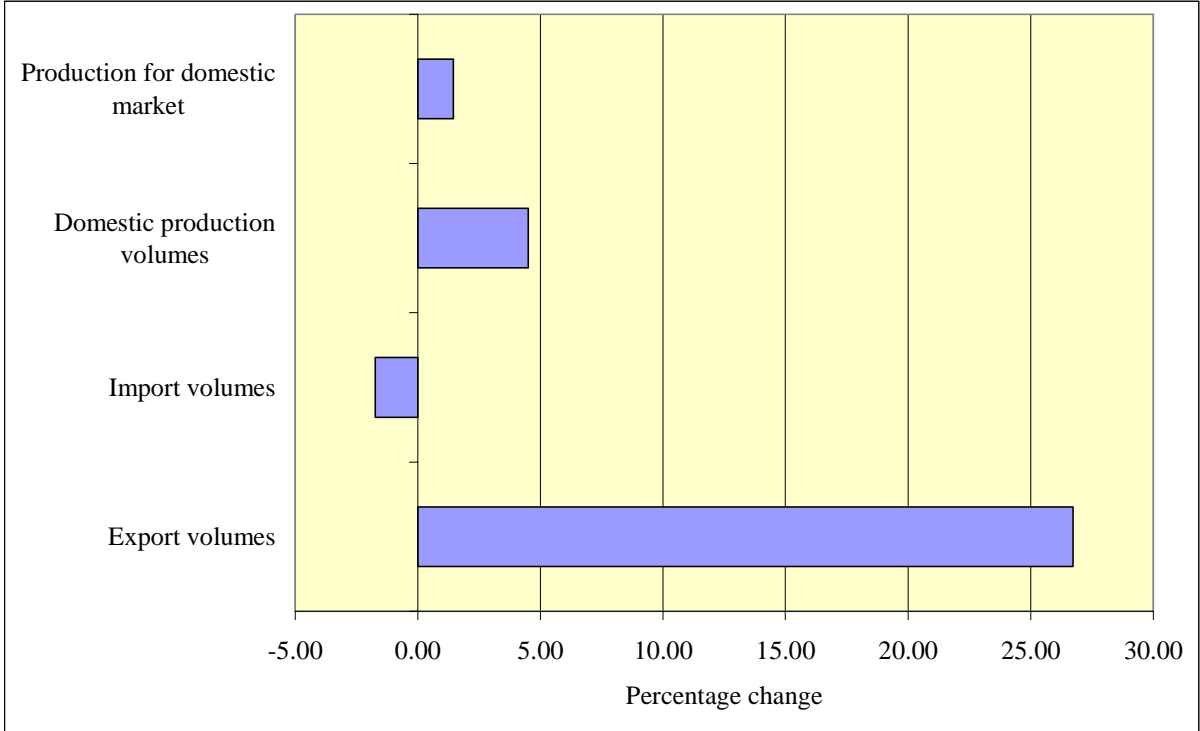

5.3. Impact on factor employment and income

The demand for factors of production, both labour and capital, by the wine industry increase by approximately 4%. The change in demand for factors is notably smaller in magnitude for other industries, ranging between 0.52% and -0.41%.

Figure 6 shows the increase in employment in South Africa, the Western Cape and Northern Cape respectively. These figures relate to employment throughout the economy, not only in the wine industry. There are 5 824 jobs created in South Africa, of which 1 229 (21%) are in the Western Cape and 84 (1%) in the Northern Cape.

**Figure 6: Number of jobs created for a 10% increase in international wine prices**

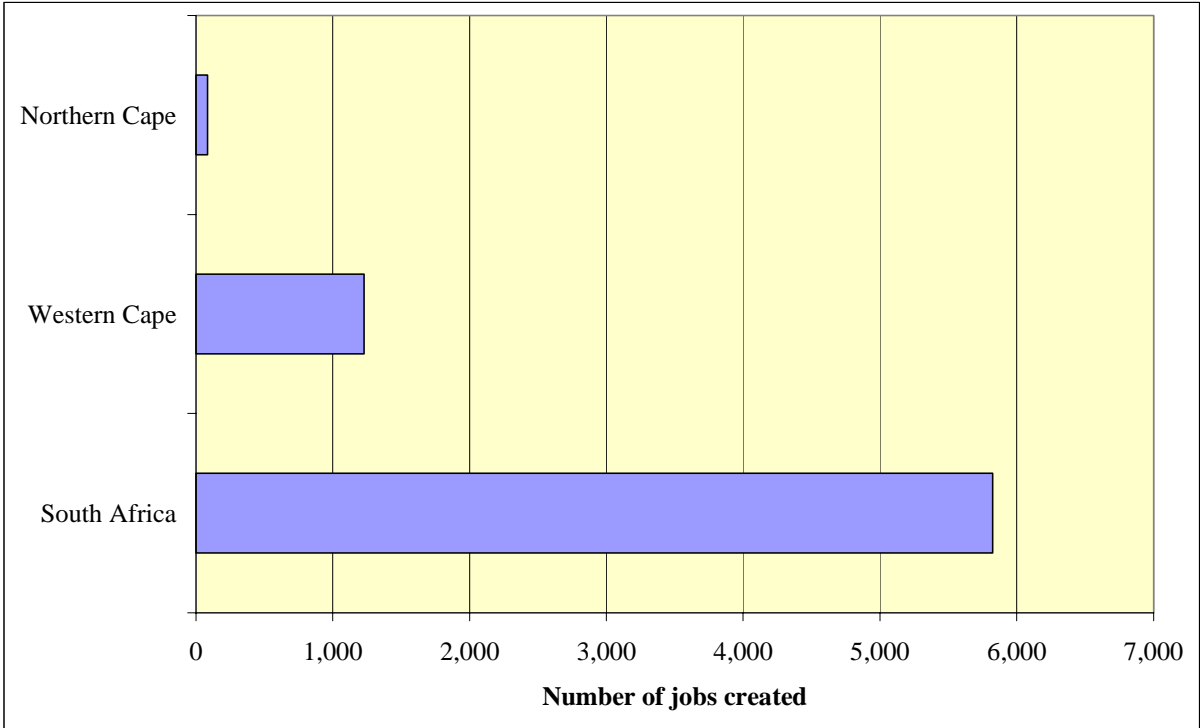

The results indicate varied changes in factor incomes ranging between 0.76% and -0.57%. Figure 7 shows results for labour in the Western Cape. Changes in factor incomes of labour are determined by changes in the wage rates for fully employed factors and changes in employment for underemployed factors. Hence, the increases in the incomes of white and skilled labour imply that the wage rates of those labour categories increase marginally, whereas the increases in the incomes of semi- and unskilled labour imply that employment increased among those labour types.

**Figure 7: Changes in incomes of labour in the Western Cape for a 10% increase in international wine prices**

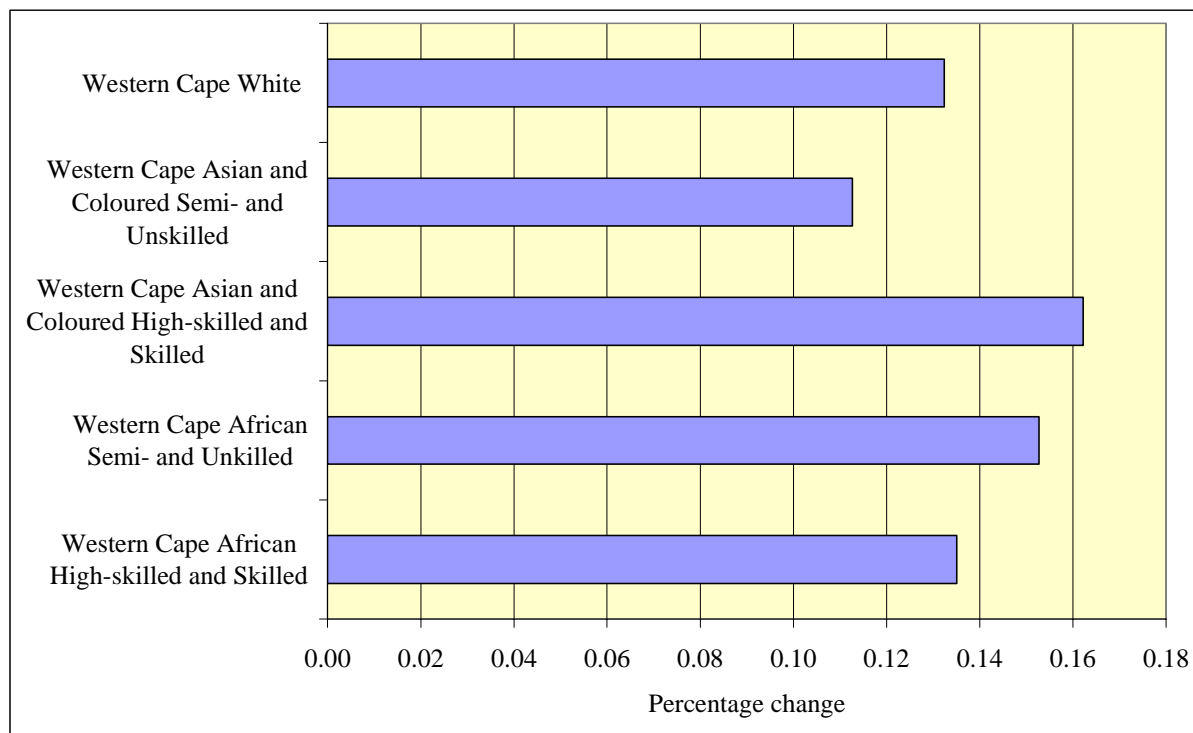

5.4. Impact on households welfare and consumption

Changes in incomes of factors, including land, capital and labour, largely explain the changes in household incomes because households are the owners of these factors. Incomes from labour services are the primary sources of household incomes, followed by incomes from capital and land. Household incomes of all identified household categories, with the exception of the low income categories of the Free State and North West, increase by up to 0.17%. The changes in household incomes for the Western Cape households are presented in Figure 8. The results indicate that the higher income categories experience relatively greater increases in their incomes. The identified households are distinguished by the education level of the head of the household in addition to province of residence and race.

**Figure 8: Changes in incomes of households in the Western Cape for a 10% increase in international wine prices**

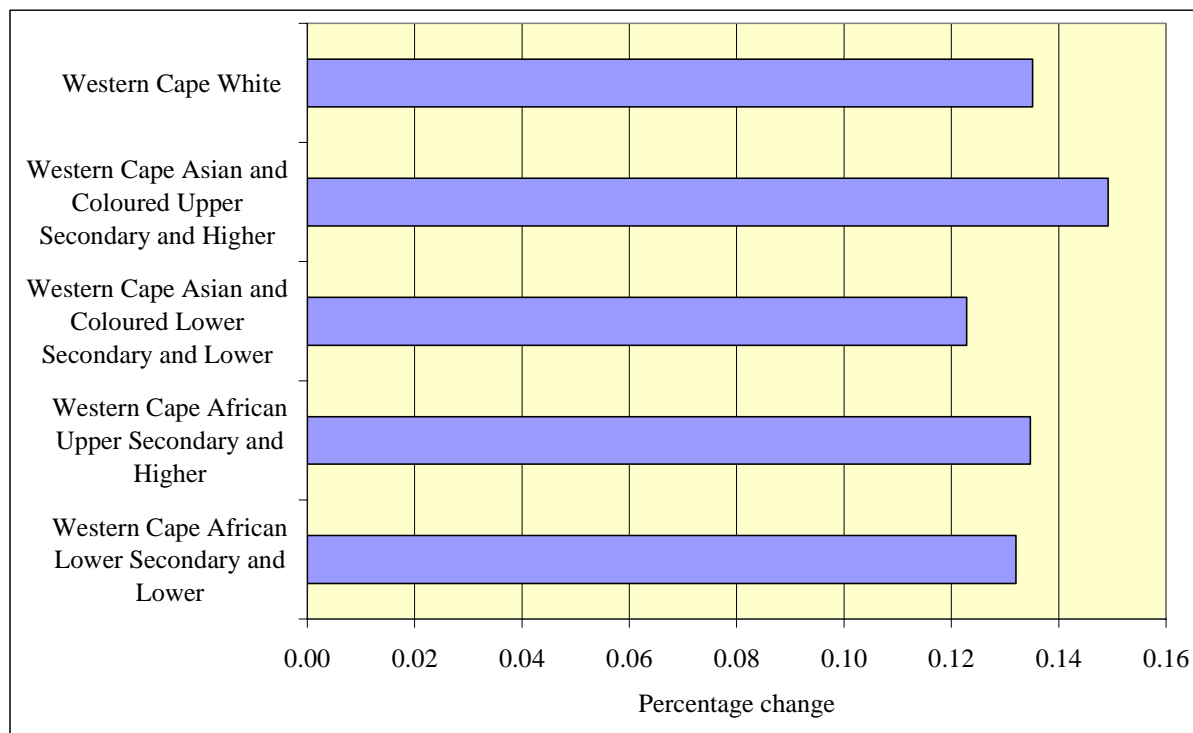

For a maintained increase of 10% in the wine export price there are welfare gains for all the representative households groups in the Western Cape - see Figure 9. The welfare gains (equivalent variation) range between R4.9m for the African households with heads of household having secondary or tertiary education and R49.2m for White households. Compared to household income, household welfare also takes into account changes in commodity prices and therefore households with different spending patterns are affected differently. The results in Figure 8 and Figure 9 indicate that the prices of the bundle of goods purchased by whites increased less than that purchased by Africans.

**Figure 9: Changes in household welfare for a 10% increase in international wine prices**

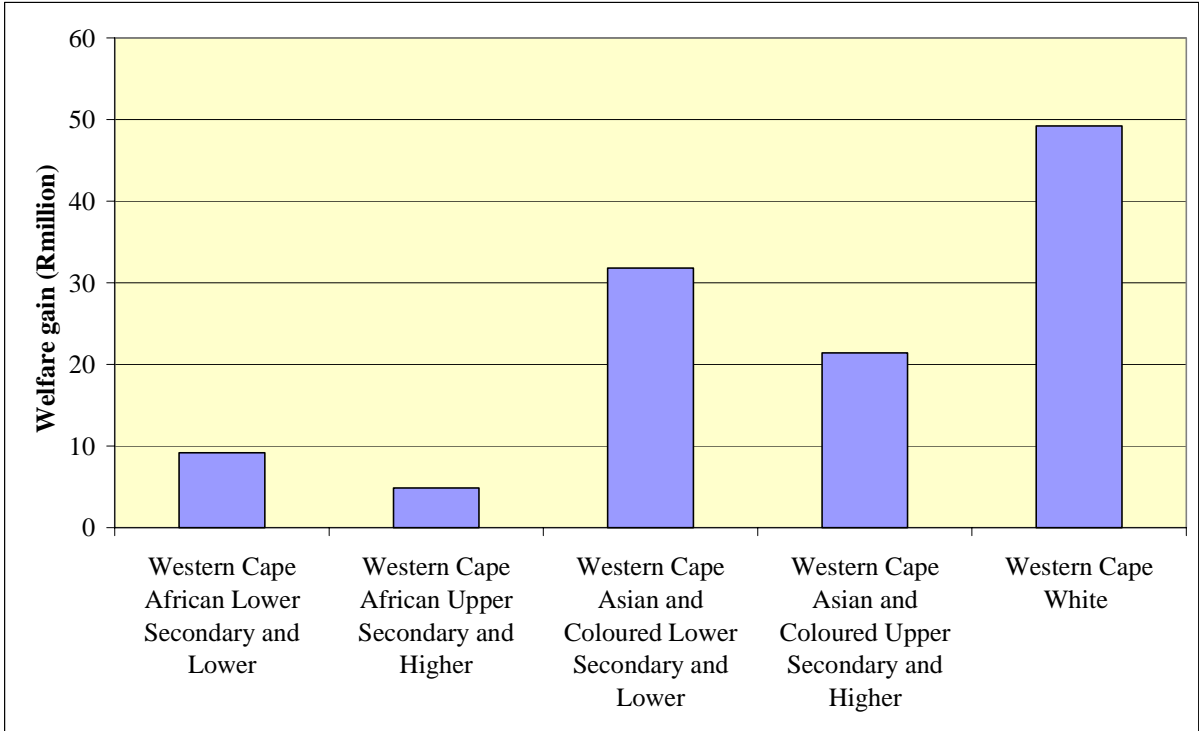

Total household consumption follows household incomes closely. Changes in domestic demand for agricultural and food products following the 10% increase in the international price of wine are indicated in Figure 10. Domestic demand for beverage and tobacco products increase by 1.45%

**Figure 10: Changes in domestic demand for agricultural and food commodities for a 10% increase in international wine prices**

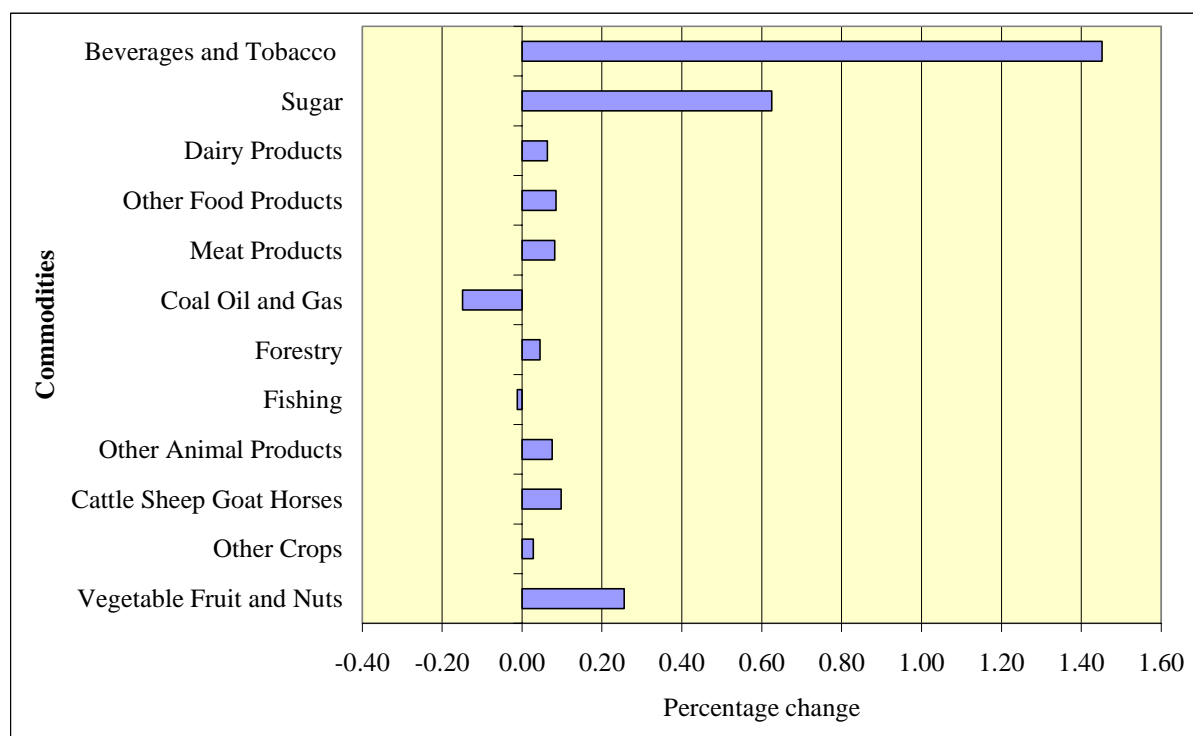

Individual households increase their (volume) consumption of wine products by up to 0.76%. In all the provinces the increase in consumption of wine products is higher for high income households relative to low income households. This increase in consumption is therefore the result of an expansion and price effect.

5.5. Impact on prices

Figure 11 shows that the purchaser price of wine products declines by 1.47% following the 10% increase in international prices, explaining the increase in consumption mentioned in the previous section. The purchaser price is directly influenced by the domestic price and the import price of a good. As a result of the depreciation of the exchange rate imported goods becomes relatively more expensive compared to domestically produced goods. The decrease in the domestic price is sufficient to offset the increase in the import price, leading to a decrease in the purchaser price. The domestic price (PD) decreases because of the increase in production for the domestic market as a result of the expansion of the industry. The beverage and tobacco industry uses a large share of its own output as intermediate input and because there is a decrease in the purchaser price of beverages and tobacco, the decrease in the price is compounded. Changes in prices of other products vary between 1.25% and -0.5%. The large increase in the price of sugar cane is stimulated by the demand for sugar for beverages.

**Figure 11: Changes in the consumer prices (PQD) of selected commodities for a 10% increase in international price of wine**

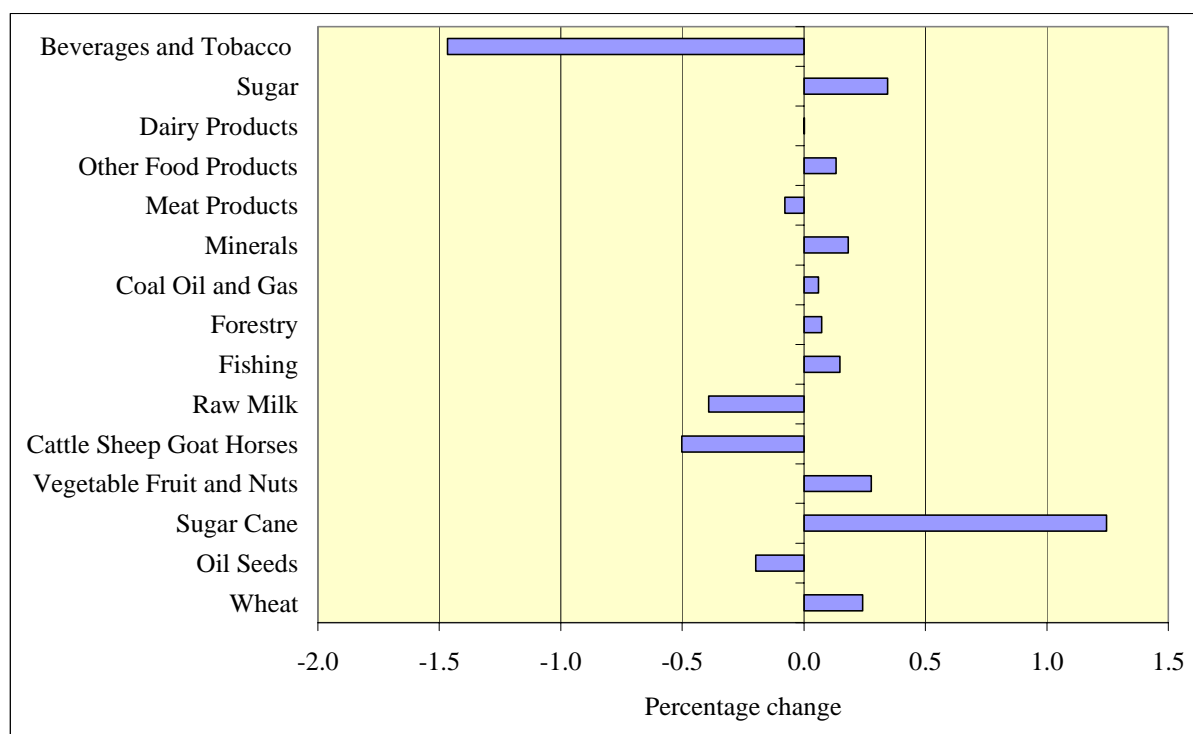

5.6. Impacts in the short-run

The results for the long run allows for capital to be withdrawn from one industry and reinvested in another industry. When the results of the short-run closure (immobile capital) are analysed it becomes apparent that the exchange rate appreciates by 0.09% (compare depreciation of 0.02% for the long-run scenario), as would be expected when exports increase. Wine exports increase by 24%, imports increase by 0.07% and domestic production increases by 3.99%. See Table 2 for a comparison with the results from the long run closure.

**Table 2: Changes in wine production and trade volumes for the long-run and short-run closure for a 10% increase in the international wine price**

|                             | Long-run | Short-run |
|-----------------------------|----------|-----------|
| Export volumes              | 26.73    | 23.99     |
| Import volumes              | -1.73    | 0.07      |
| Domestic production volumes | 4.50     | 3.99      |

The price of value added is indicative of the resources available to attract production factors to an industry. The increase in the price of value added for the wine industry is higher in the short-run (2.06%) than in the long-run (0.09%). The returns to capital in the wine industry relative to other industries increase over the short-run (when it is assumed that capital cannot relocate from other industries). These results are indicative of the fact that

capital is a binding constraint in the wine industry over the short term and that the majority of the additional revenue to the industry from increased exports, will be realised as higher returns to capital. This is substantiated by the fact that the returns to capital, as a share of returns to all factors of production in the wine industry, are relatively high (67%).

The implication for the industry is that additional capital will be invested in the industry over the longer term if the marketing strategy is perceived to be successful. Only if the industry can expand sufficiently to supply the additional demand will the full benefit of higher international prices be realised as indicated in the results discussed above. The underlying assumption of the results is that the 10% increase in international price is a sustained increase, therefore warranting further investment in the wine industry.

## 6. Conclusion

A marketing strategy undertaken by role players in the wine industry is expected to lead to an increase in South African wine exports. A multi-sector analysis, which takes into account the linkage effects in an economy, was conducted to estimate the impact of an increase in wine exports on the South African economy. In the long run the international demand for South African wine will be determined by consumer perceptions about the South African product and its price relative to competitors. If the international demand for South African wine expands then the export price should increase relative to the price received by international competitors, and, in terms of the model, the domestic market price; assuming that the domestic market perception does not increase as much as the international perception. In the context of a relative price based Computable General Equilibrium model, this would manifest as an increase in the export price.

Results of a 10% increase in the international wine price indicated an increase of 0.1% in gross domestic product (GDP). The exchange rate shows a depreciation of 0.02%, while the value of total exports and imports for South Africa both increase by approximately 0.14%. The increase in imports is stimulated by a net increase in factor incomes and hence expendable household incomes. The general positive effect on the economy is also reflected by the creation of 5 824 employment opportunities, of which 20% is in the Western Cape. Factor incomes show varied results with changes ranging between 0.76% and -0.57% for labour groups throughout South Africa. Factor incomes increase for all five labour groups identified in the Western Cape (increase between 0.11% and 0.16%). Expendable household incomes show similar trends.

Although aggregate expenditure by households tend to increase, consumption of individual products show both increases and decreases in demand depending on movements in commodity prices of individual products. The purchaser price of wine decreases by 1.47%

and domestic consumption increases by 1.45%. This increase in demand is the result of an income and price effect. In order to meet the increase in domestic demand, as well as the increase of 26.7% in the volume of exports, domestic production of wine increases by 4.5%. The volume of wine imports decline by 1.73%.

Comparing long-run and short-run results it becomes evident that capital might be a binding constraint over the short-run, but seen in the light that in practice the increase in the international price will not happen overnight, this becomes less of an obstacle. A successful marketing strategy, which leads to sustained increases in the international price of South African wine, is however likely to require additional investment in the industry in order for the industry to expand sufficiently to reap the benefits of the increase in export demand.

## 7. References

- Armington, P.S. (1969). "A theory of demand for products distinguished by place of production". IMF Staff papers, Vol. 16.
- Dervis, K., De Melo, J. and Robinson, S. (1982). "General Equilibrium Models for Development Policy". New York, Cambridge University Press.
- Devarajan, S., Lewis, J.D. and Robinson, S. (1994). "Getting the Model Right: The General Equilibrium Approach to Adjustment Policy". Mimeo.
- Kilkenny, M. (1991). "Computable General Equilibrium Modelling of Agricultural Policies: Documentation of the 30-Sector FPGE GAMS Model of the United States", USDA ERS Staff Report AGES 9125.
- Joubert, L. (2006). "S.A. yet to find a sense of 'place' ". WOSA News. Wines of South Africa (WOSA), Stellenbosch.
- Minnaar, M. "South African wine". South African Info, online article available at:  
[http://www.southafrica.info/plan\\_trip/holiday/food\\_wine/wine.htm](http://www.southafrica.info/plan_trip/holiday/food_wine/wine.htm)
- PROVIDE (2005). "The PROVIDE Project Standard Computable General Equilibrium Model". PROVIDE Technical Paper Series 2005:3.
- PROVIDE (2006). "A Social Accounting Matrix for South Africa: 2000." PROVIDE Technical Paper Series. Forthcoming.
- Pyatt, G. (1998). "A SAM Approach to Modelling." Journal of Policy Modelling 10: 327-352.
- Robinson, S., Kilkenny, M. and Hanson, K. (1990). "USDA/ERS Computable General Equilibrium Model of the United States". USDA ERS Staff Report AGES 9049.
- SARS (2005) South African Postal Code Data for 2005. South African Revenue Service, Pretoria.
- SAWIS (2006) South African Wine Industry Statistics No 30. South African Wine Industry Information and Systems (SAWIS), Paarl.

The following websites have been useful in giving a general picture of the South African wine industry.

[www.south-africa-tours.com/wine-wine-routes](http://www.south-africa-tours.com/wine-wine-routes)

[www.wine.co.za](http://www.wine.co.za)

[www.WINEmag.co.za](http://www.WINEmag.co.za)

[www.wosa.co.za](http://www.wosa.co.za)

## 8. Appendices

### 8.1. Appendix A: SAM Accounts

|                                     |  |
|-------------------------------------|--|
| <b>Commodities</b>                  | <b>(Activities continued)</b>  |
| 1 Other Cereals                     | 43 Meat  |
| 2 Wheat                             | 44 Other Food  |
| 3 Oil Seeds                         | 45 Dairy   |
| 4 Sugar Cane                        | 46 Sugar   |
| 5 Wine grapes                       | 47 Beverages and Tobacco   |
| 6 Vegetable Fruit and Nuts          | 48 Apparel and Textile   |
| 7 Other Crops                       | 49 Wood  |
| 8 Cattle Sheep Goat Horses          | 50 Petroleum Chemicals and Minerals                                  |
| 9 Raw Milk                          | 51 Metal   |
| 10 Other Animal Products            | 52 Other Manufacturing   |
| 11 Fishing                          | 53 Vehicle and Transport   |
| 12 Forestry                         | 54 Utilities   |
| 13 Coal Oil and Gas                 | 55 Construction  |
| 14 Minerals                         | 56 Transport and Trade   |
| 15 Meat Products                    | 57 Services  |
| 16 Other Food Products              | <b>Factors</b>   |
| 17 Dairy Products                   | 58 Gross Operating Surplus Mixed Income                              |
| 18 Sugar                            | 59 Western Cape Land   |
| 19 Beverages and Tobacco            | 60 Northern Cape Land  |
| 20 Apparel and Textile              | 61 North West Land   |
| 21 Wood Product                     | 62 Free State Land   |
| 22 Petroleum Chemicals and Minerals | 63 Eastern Cape Land   |
| 23 Metal Products                   | 64 KwaZulu-Natal Land  |
| 24 Other Manufactures               | 65 Mpumalanga Land   |
| 25 Vehicle and Transport            | 66 Limpopo Land  |
| 26 Utilities                        | 67 Gauteng Land  |
| 27 Construction                     | 68 Western Cape African High-skilled and Skilled                     |
| 28 Transport and Trade              | 69 Western Cape African Semi- and Unskilled                          |
| 29 Services                         | 70 Western Cape Asian and Coloured High-skilled and Skilled          |
| <b>Activities</b>                   | 71 Western Cape Asian and Coloured Semi- and Unskilled               |
| 30 Western Cape Agriculture         | 72 Western Cape White  |
| 31 Northern Cape Agriculture        | 73 Eastern Cape African Asian and Coloured High-skilled and Skilled  |
| 32 North West Agriculture           | 74 Eastern Cape African Asian and Coloured Semi- and Unskilled       |
| 33 Free State Agriculture           | 75 Eastern Cape White  |
| 34 Eastern Cape Agriculture         | 76 Northern Cape African Asian and Coloured High-skilled and Skilled |
| 35 KwaZulu-Natal Agriculture        | 77 Northern Cape African Asian and Coloured Semi- and Unskilled      |
| 36 Mpumalanga Agriculture           | 78 Northern Cape White   |
| 37 Limpopo Agriculture              | 79 Free State African Asian and Coloured High-skilled and Skilled    |
| 38 Gauteng Agriculture              |  |
| 39 Forestry                         |  |
| 40 Fishing                          |  |
| 41 Coal Oil and Gas                 |  |
| 42 Minerals                         |  |

| <b>Factors (continued)</b>   | <b>Households (continued)</b>  |
|--|--|
| 80 Free State African Asian and Coloured Semi- and Unskilled           | 109 Northern Cape White  |
| 81 Free State White  | 110 Free State African Asian and Coloured Lower Secondary and Lower  |
| 82 KwaZulu-Natal African High-skilled and Skilled                      | 111 Free State African Asian and Coloured Upper Secondary and Higher |
| 83 KwaZulu-Natal African Semi- and Unskilled                           | 112 Free State White   |
| 84 KwaZulu-Natal Asian and Coloured High-skilled and Skilled           | 113 KwaZulu-Natal African Lower Secondary and Lower                  |
| 85 KwaZulu-Natal Asian and Coloured Semi- and Unskilled                | 114 KwaZulu-Natal African Upper Secondary and Higher                 |
| 86 KwaZulu-Natal White   | 115 KwaZulu-Natal Asian and Coloured Lower Secondary and Lower       |
| 87 North West African Asian and Coloured High-skilled and Skilled      | 116 KwaZulu-Natal Asian Upper Secondary and Higher                   |
| 88 North West African Asian and Coloured Semi- and Unskilled           | 117 KwaZulu-Natal White  |
| 89 North West White  | 118 North West African Asian and Coloured Lower Secondary and Lower  |
| 90 Gauteng African Asian and Coloured High-skilled and Skilled         | 119 North West African Upper Secondary and Higher                    |
| 91 Gauteng African Asian and Coloured Semi- and Unskilled              | 120 North West White   |
| 92 Gauteng White   | 121 Gauteng African Asian and Coloured Lower Secondary and Lower     |
| 93 Mpumalanga African Asian and Coloured High-skilled and Skilled      | 122 Gauteng African Asian and Coloured Upper Secondary and Higher    |
| 94 Mpumalanga African Asian and Coloured Semi- and Unskilled           | 123 Gauteng White Lower Secondary and Lower                          |
| 95 Mpumalanga White  | 124 Gauteng White Upper Secondary and Higher                         |
| 96 Limpopo African Asian and Coloured High-skilled and Skilled         | 125 Mpumalanga African Asian and Coloured Lower Secondary and Lower  |
| 97 Limpopo African Asian and Coloured Semi- and Unskilled              | 126 Mpumalanga African Upper Secondary and Higher                    |
| Limpopo White  | 127 Mpumalanga White   |
| 98 <b>Households</b>   | 128 Limpopo African Asian and Coloured Lower Secondary and Lower     |
| 99 Western Cape African Lower Secondary and Lower                      | 129 Limpopo African Upper Secondary and Higher                       |
| 100 Western Cape African Upper Secondary and Higher                    | 130 Limpopo White  |
| 101 Western Cape Asian and Coloured Lower Secondary and Lower          | <b>Other</b>   |
| 102 Western Cape Asian and Coloured Upper Secondary and Higher         | 131 Import Duties  |
| 103 Western Cape White   | 132 Sales Tax  |
| 104 Eastern Cape African Asian and Coloured Lower Secondary and Lower  | 133 Production Taxes   |
| 105 Eastern Cape African Asian and Coloured Upper Secondary and Higher | 134 Direct Income Taxes  |
| 106 Eastern Cape White   | 135 Government   |
| 107 Northern Cape African Asian and Coloured Lower Secondary and Lower | 136 Business Enterprises   |
| 108 Northern Cape Asian and Coloured Upper Secondary and Higher        | 137 Savings  |
|  | 138 Stock Changes  |
|  | 139 Rest of the World  |
|  | 140 Account Totals   |

8.2. Appendix B: Classification of occupations into skill level categories

| <b>Factor code</b> | <b>Description</b>                                | <b>Skill classification</b> |
|--------------------|---|-----------------------------|
| 0                  | Not applicable/not working                        | Not applicable              |
| 1                  | Legislators, senior officials and managers        | High skilled                |
| 2                  | Professionals                                     | High skilled                |
| 3                  | Technical and associate professionals             | High skilled                |
| 4                  | Clerks  | Skilled                     |
| 5                  | Service workers and shop and market sales workers | Skilled                     |
| 6                  | Skilled agricultural and fishery workers          | Semi-skilled                |
| 7                  | Craft and related trades workers                  | Semi-skilled                |
| 8                  | Plant and machine operators and assemblers        | Semi-skilled                |
| 9                  | Elementary Occupation                             | Unskilled                   |
| 10                 | Domestic workers                                  | Unskilled                   |
| 11*                | Not adequately or elsewhere defined, unspecified  | Unskilled                   |

\*Code 11 may include semi-skilled, skilled and/or high skilled workers as well, but it is almost impossible to determine.

### **Working Papers in this Series**

| <b>Number</b> | <b>Title</b>  | <b>Date</b>    |
|---------------|---|----------------|
| WP2004:1      | Trade Liberalisation, Efficiency, and South Africa's Sugar Industry   | July 2004      |
| WP2004:2      | The Welfare Impacts of Domestic and International Agricultural Efficiency Gains: A South African Case Study | December 2004  |
| WP2005:1      | The Impact of Oil Price Increases in the South African Economy  | February 2005  |
| WP2005:2      | Costs and Benefits of Higher Tariffs on Wheat Imports – A General Equilibrium Analysis                      | April 2005     |
| WP2005:3      | Quantifying the economic divide in South African agriculture: An income-side analysis                       | September 2005 |
| WP2005:4      | The impact of a higher fuel levy on the Western Cape  | November 2005  |
| WP2005:5      | General Equilibrium Effects in the South African Maize Market: International Trade Simulations              | November 2005  |
| WP2005:6      | The welfare impacts of targeted transfers to poor households  | December 2005  |
| WP2006:1      | The impact of increasing excise duties on the economy   | March 2006     |
| WP2006:2(1)   | The impact of property rates on agricultural land, focusing on the Free State                               | March 2006     |
| WP2006:2(2)   | The impact of property rates on agricultural land, focusing on Limpopo                                      | June 2006      |
| WP2006:2(3)   | The impact of property rates on agricultural land, focusing on the Western Cape                             | June 2006      |
| WP2006:2(4)   | The impact of property rates on agricultural land, focusing on the Northern Cape                            | June 2006      |
| WP2006:2(5)   | The impact of property rates on agricultural land, focusing on the Eastern Cape                             | June 2006      |
| WP2006:2(6)   | The impact of property rates on agricultural land, focusing on the KwaZulu-Natal                            | June 2006      |
| WP2006:2(7)   | The impact of property rates on agricultural land, focusing on the Mpumalanga                               | June 2006      |
| WP2006:2(8)   | The impact of property rates on agricultural land, focusing on the North West                               | June 2006      |
| WP2006:2(9)   | The impact of property rates on agricultural land, focusing on the Gauteng                                  | June 2006      |
| WP2006:3      | The impact of an increase in wine industry exports on the SA economy  | November 2006  |

### **Other PROVIDE Publications**

Technical Paper Series  
Background Paper Series  
Research Reports