

Working Paper Series

PROVIDE
PROJECT
The Provincial Decision-making Enabling Project

Working Paper 2005:6

**The welfare impacts of targeted
transfers to poor households**

Elsenburg
November 2005

PROVIDE

PROJECT

The Provincial Decision-making Enabling Project

Overview

The Provincial Decision-Making Enabling (PROVIDE) Project aims to facilitate policy design by supplying policymakers with provincial and national level quantitative policy information. The project entails the development of a series of databases (in the format of Social Accounting Matrices) for use in Computable General Equilibrium models.

The National and Provincial Departments of Agriculture are the stakeholders and funders of the PROVIDE Project. The research team is located at Elsenburg in the Western Cape.

PROVIDE Research Team

Project Leader:	Cecilia Punt
Senior Researchers:	Kalie Pauw Melt van Schoor
Young Professional:	Bonani Nyhodo
Technical Expert:	Scott McDonald
Associate Researchers:	Lindsay Chant Christine Valente

PROVIDE Contact Details

 Private Bag X1
Elsenburg, 7607
South Africa

 provide@elsenburg.com

 +27-21-8085191

 +27-21-8085210

For the original project proposal and a more detailed description of the project, please visit www.elsenburg.com/provide

The welfare impact of targeted transfers to poor households ¹

Abstract

Despite widespread poverty there is general consensus among policymakers about the preference of targeted welfare transfers over non-targeted grants due to the budgetary implications of the latter. Targeting, however, adds to the administrative complexities of disbursing welfare grants, thus introducing a cost dimension that is as yet largely unexplored. In this paper a series of targeted transfer simulations are run in a general equilibrium model calibrated with a Social Accounting Matrix for South Africa. Deficit financing and tax replacement policies are considered as financing options, assuming a hypothetical budget constraint of R15 billion. The effectiveness of broad targeting and a low per capita transfer value versus narrow targeting and high transfer value in terms of reducing poverty and inequality is explored. Results on per capita expenditure changes (disposable income) from the general equilibrium model are extracted and fed into a micro-level survey-based module that calculates poverty and inequality at the individual level. Preliminary results suggest that the poverty impact is small: the poverty headcount falls from about 49% in the base to approximately 46% in the simulations. However, for some household groups poverty may actually increase due to the increases tax burden, also on households that are close to the poverty line. This highlights the importance of ensuring an equitable distribution of the increased tax burden. Inequality also declines marginally in all the simulations considered, mainly because poor households are targeted while non-poor households typically carry a larger share of the increased tax burden. In as far as the effectiveness of broad versus narrow targeting is concerned the results suggest that narrower targeting generally implies greater reductions in poverty and inequality, although it depends crucially on how far the transfer recipients are located from the poverty line.

¹ The author of this paper is Kalie Pauw.

Table of Contents

1. Introduction	4
2. Social welfare in South Africa	4
3. Measuring poverty and inequality	7
3.1. Data	7
3.2. Poverty	8
3.2.1. Poverty measurement	8
3.2.2. South African poverty lines	10
3.2.3. A poverty profile for South Africa	16
3.3. Inequality	18
4. Model and data	21
4.1. Model description	21
4.1.1. Behavioural Relationships	22
4.1.2. Price and Quantity Relationships	25
4.2. Social Accounting Matrix	27
5. Simulation setup	28
5.1. Overview	28
5.2. Targeting representative household groups	28
5.2.1. West Coast region	30
5.2.2. East Coast region	34
5.2.3. Central Region	38
5.2.4. Border Region	42
5.3. Closures	45
5.3.1. Government closure	45
5.3.2. Factor market closures	45
5.3.3. Other closures	47
5.4. Final remarks about the model setup and simulations	48
6. Results	49
6.1. CGE model results	49
6.1.1. The government closure and administration costs	49
6.1.2. Unemployment closures	52
6.1.3. Long run and short-run closures	54
6.1.4. Aggregate household welfare effects	55
6.2. Linking the CGE results to the survey data	58
6.2.1. Method	58
6.2.2. Results	59
7. Conclusions	62
8. References	63
9. Appendix	65
9.1. Construction of representative household groups for the PROVIDE SAM	65
9.2. Poverty rates for various population sub-groups	66
9.3. Employment impact and the deficit financing closure	71
9.4. Accounts in the SAM	72
9.5. Welfare effects – additional graphs	74
9.6. Technical notes on dataset, weights and variables	77

List of Figures

Figure 1: Comparison of estimated poverty rates using different sampling weights.....	15
Figure 2: Price Relationships for a Standard Model with Commodity Exports	26
Figure 3: Quantity Relationships for a Standard Model	27
Figure 4: The trade-off between transfer value and the number of recipients	30
Figure 5: Deficit financing and balanced budget simulations	51
Figure 6: Changes in employment levels under different closure assumptions.....	53
Figure 7: Changes in average wages under different closure assumptions.....	54
Figure 8: Welfare changes using the Slutsky approximation technique.....	56
Figure 9: Welfare changes by province	57
Figure 10: Comparing welfare effects between recipient and non-recipient households	58
Figure 11: National-level poverty headcount ratio and the depth of poverty	59
Figure 12: Regional-level poverty headcount ratio	60
Figure 13: Poverty headcount ratios across racial groups	61
Figure 14: Poverty headcount ratios and the gender of the household head.....	61
Figure 15: Changes in per capita income and inequality estimates	62
Figure 16: Household expenditure changes by province.....	74
Figure 17: Comparing consumption effects between targeted and non-targeted households..	75
Figure 18: Regional-level depth of poverty	76
Figure 19: Depth of poverty across racial groups	76
Figure 20: Depth of poverty and the gender of the household head	77

List of Tables

Table 1: Poverty and household size and structure.....	12
Table 2: Identification the poor under the ‘per capita’ and ‘adult equivalent’ approaches	13
Table 3: Theil inequality measure: within and between group decomposition	21
Table 4: Relationships for the Computable General Equilibrium Model.....	24
Table 5: Poverty rates and targeted household groups in the West Coast region.....	32
Table 6: Poverty rates and targeted household groups in the East Coast region	35
Table 7: Poverty rates and targeted household groups in the Central region	39
Table 8: Poverty rates and targeted household groups in the Border region	43
Table 9: Labour group classifications.....	47
Table 9: Closures in the model.....	48
Table 11: Compositional shift in the demand for the factor capital (long run closure).....	55
Table 12: Poverty rates and poverty distribution by race	66
Table 13: Poverty rates and poverty distribution by province	67
Table 14: Poverty rates and poverty distribution by region.....	67
Table 15: Poverty rates and poverty distribution by location (a).....	68
Table 16: Poverty rates and poverty distribution by location (b)	68
Table 17: Poverty rates and poverty distribution in the former homelands (a)	69
Table 18: Poverty rates and poverty distribution in the former homelands (b)	69
Table 19: Poverty rates and poverty distribution by gender	70
Table 20: Poverty rates and poverty distribution by age groups.....	70
Table 21: Poverty rates and poverty distribution by gender of the household head	70
Table 22: Poverty rates and poverty distribution by education level of the household head...	70
Table 23: Accounts in the model SAM	72

1. Introduction

Despite South Africa's official status as an upper middle-income country it is characterised by extreme degrees of inequality in the distribution of income, assets and opportunities. Past discriminatory policies have left a large proportion of the population outside the economic mainstream and relatively poor compared to an elite minority. Thurlow (2002) warns that the high degree of relative poverty (or inequality) should not overshadow the high incidence of absolute poverty that also persists in this country. Depending on the definition of the absolute poverty line, current poverty levels of between 45% and 55% are often quoted in the literature (see for example Hoogeveen and Özler, 2004, and others, May, 1998, Taylor, 2002, Woolard and Leibbrandt, 2001). Given the severity of poverty in South Africa it is arguable that the government's first concern should be that of reducing absolute poverty.

In this paper we evaluate the impact of increases in welfare transfers to households in a Computable General Equilibrium (CGE) framework. While similar studies have been done in the past (see McDonald and Punt, 2003, and Thurlow, 2002), neither of these considered the impact of *targeted* transfers, while more detailed micro-level analyses were also largely excluded. In this paper highly disaggregated household accounts, a comprehensive welfare module in the CGE model used, and some preliminary attempts at linking results to the micro- (or survey-) level add to the analysis.

2. Social welfare in South Africa

Since the inception of democratic rule in South Africa in 1994 debates have taken place to try and reach agreement on what measures should be taken to redress imbalances and uplift the poor. Immediately after coming into power the ANC government committed itself to specific goals in the area of social policy, which included, among other things, eliminating poverty, achieving an acceptable distribution of income, and lowering unemployment levels through programmes of social assistance (Taylor, 2002). Government even went as far as entrenching the right to social assistance in the Constitution [s27(1)(c)] (see Haarmann, 2001a), a bold move that has made them vulnerable to Constitutional Court challenges as was seen in the now famous *State versus Grootboom* case in 2000 (Taylor, 2002).

The new political era saw various policy documents come to the fore, most notably the Reconstruction and Development Programme (RDP), which was later replaced by the Growth, Employment and Redistribution programme (GEAR) in 1996. Both these policy strategies placed poverty reduction and redistribution high on the list of achievable objectives. GEAR envisaged "*sustained growth on a higher plane*" as its main point of departure and the solution to the low rate of job creation, which in turn would lead to a more equitable

distribution of income (Republic of South Africa, 1996). Although the optimistically high economic growth rates predicted by GEAR never materialised, the economy performed reasonably well in an unstable international environment. However, despite this slight economic resurgence, formal employment continued to fall during the latter half of the 1990s.

Various studies done in recent years have established the link between unemployment (or under-employment) and poverty in South Africa (see for example May, 1998). Given that formal employment levels have declined during the last decade there is reason to believe that this may have adversely affected poverty levels. A recent study by Hoogeveen and Özler (2004) confirms this. They compare poverty levels based on Statistics South Africa's Income and Expenditure Surveys (IES) of 1995 (SSA, 1997) and 2000 (SSA, 2002a) and find that per capita household expenditure levels have decreased, while poverty, and especially extreme poverty, has increased between 1995 and 2000. Overall inequality in the distribution of income has also increased due to higher inequality among African households. This is an indication that the economy is "*highly inefficient in converting economic resources into equitable social welfare outcomes*" (Leibbrandt *et al.*, 2001a:1).

Reasons for the failure of the economy to generate employment opportunities are well documented (see Pauw and Edwards, 2003 for a summary). There is general consensus that structural problems in the labour market lie behind the phenomenon of jobless growth. For some time now the failure of the economy to improve conditions for the poor through growth has been the basis for arguments in favour of direct interventionist social welfare policies. This was also the opinion of the Taylor Report on the findings of a Committee of Inquiry into a Comprehensive System of Social Security for South Africa (Taylor, 2002).

The Taylor Committee maintains that the underlying assumption of the "*old [social security] system*" is that the employed can support themselves through work and that unemployment is temporary (Taylor, 2002: 15). In an ideal world people should be earning a living through employment rather than rely on social welfare. However, given the structural nature of the unemployment problem full employment is an unlikely prospect for the near future. This requires a "*fresh look at social protection systems more appropriate to their environments and needs*" (Taylor, 2002: 154).

The Taylor Committee also found various gaps in the social security net, *inter alia* (Taylor, 2002:9):

- Unemployment insurance offers benefits to only 6% of the unemployed.
- Disability provisions are either not comprehensive enough or overlaps exist between various funds due to a badly bad designed system.

- Child benefits and old age pensions were found to be insufficient

Given the deficiencies of the existing social security system and the fact that poverty is widespread, there is a dire need for a comprehensive social security system. A complete overhaul of the old system seems the appropriate thing to do, but it is generally recognised that the poor administrative capacity of government, especially at local level, remains a major constraint to public service reform and delivery. The unique circumstances in South Africa gave weight to the idea of a universal grant such as the proposed Basic Income Grant (BIG), which first surfaced in 1997 when Jeremy Baskin put it forward in an article in the *Mail & Guardian* (Haarmann, 2001b).

A BIG can be administered fairly easily as it entails a system whereby everyone in the country receives the same grant. This implies that no means testing or targeting is involved. It also ensures that no individual falls through gaps in the system. Given the apparent advantages of a BIG it quickly gained widespread support. Some of the more prominent supporters included the Congress of South African Trade Unions (COSATU), who proposed the implementation of such a measure at the Presidential Job Summit in 1998 (Haarmann, 2001b), and the South African Council of Churches (SACC), who formally gave their support for a BIG in 2001 (McDonald and Punt, 2003).

The Taylor Committee gave the idea of a BIG serious consideration, but remained cautious. Although they recognised its merits as part of a comprehensive social protection framework, they questioned the fiscal feasibility of it. Doubts about BIG's feasibility were also expressed by Thurlow (2002). Using a Computable General Equilibrium (CGE) model for South Africa he finds that the cost of such a scheme could be debilitating to the economy, whether it is financed by raising income and/or sales taxes or by reducing other government expenditures. Thurlow also questions the merits of a universal grant over a targeted grant and suggests that more research is necessary. McDonald and Punt focus more on the issue of targeting when they investigate the impact of a BIG in the Western Cape province. They find that an "*enhanced but targeted income grant*" achieves a higher degree of poverty alleviation than a universal BIG (2003: 1).

What was probably the final nail in the BIG coffin came from Trevor Manuel early in 2004, when he announced that the government's approach is to "*extend social security and income support through targeted measures*" rather than through a universal BIG. He regards this as the "*more balanced strategy for social progress and sustainable development*" (Budget Speech, February 2004).

Although targeting of welfare transfer payments is necessary in order to reduce the cost of the scheme, targeting also brings with it a number of complications. Most notably are the high

administration cost and potential administrative complexities. Given the low administrative capacity in South Africa, as well as the fact that unemployment and poverty is widespread, policymakers are often tempted to opt for broader targeting. Very little research has been done to try and estimate what the implementation cost would be of targeted income grants. The fact that estimates of implementation costs are scarce or unavailable remains one of the major constraints faced by researchers wishing to model the economic impact of targeted social security measures.

3. Measuring poverty and inequality

In this section the poverty and inequality literature is reviewed briefly with a specific reference to South African research. The data source used for the analysis is discussed briefly, followed by a fairly detailed review of poverty measurement, poverty lines and a South African poverty profile. Although the main focus of the paper is on poverty, the section concludes with some comments and analyses about inequality in South Africa.

3.1. Data

There are various sources of demographic and income/expenditure data available in South Africa. Statistics South Africa conducts a variety of regular surveys. Most suited to this particular study is the Income and Expenditure Survey of 2000 (IES 2000) (SSA, 2002a) as well as the LFS September 2000 (LFS 2000:2) (SSA, 2002b). The IES is conducted every five years and at present the 2000 dataset is the latest available version. The Labour Force Survey is conducted twice every year and the latest available version is the September 2003 (SSA, 2004) dataset. However, the LFS 2000:2 is used since it is based on the same sample of households as the IES 2000 and therefore the two datasets can be merged. The merged dataset integrates detailed person-level employment, education and demographic statistics from the LFS 2000:2 with the household-level income and expenditure data in the IES 2000. Although there are some concerns about the reliability of the IES and LFS datasets, whether merged or used separately, as well as the comparability of these with other datasets, it remains the most recent and comprehensive source of combined household income/expenditure and employment information in South Africa.² The IES/LFS 2000 database was also used in the construction of household groups for the PROVIDE SAM (see section 9.1).

² This merged database is referenced as IES/LFS 2000 in this paper and is the source of all figures and tables, unless indicated otherwise. For a detailed description of the database, an outline of the data problems, and data adjustments made to the version used in this paper, refer to PROVIDE (2005b).

3.2. Poverty

3.2.1. *Poverty measurement*

Poverty is loosely defined by The World Bank as the “*inability to attain a minimal standard of living*” (as cited in Woolard and Leibbrandt, 2001:42). Poverty analysis, therefore, is an attempt to define this minimal standard of living or welfare level in terms of a poverty line, and to then study those household or individuals that fall below it. The latter step usually involves using survey data to analyse demographic and other characteristics of poor households or individuals. It also involves calculating various poverty measures, such as poverty rates or measures of the depth of poverty. The actual poverty rate (incidence) tells us what proportion of the population is poor as measured against the selected poverty line. The depth of poverty gives an indication of how far below, on average, poor households are from the selected poverty line.

The literature distinguishes between two types of poverty lines, namely absolute and relative poverty lines. An absolute poverty line is some specific welfare level below which a household is deemed poor. Two approaches to measuring ‘welfare’, ‘well-being’ or ‘standard of living’ exist, namely the welfarist approach and the non-welfarist approach (Woolard and Leibbrandt, 2001). The welfarist approach considers total income earned or expenditure on all goods and services as the measure of welfare. A technique called the ‘cost of basic needs’ approach can then be used to calculate the value of a basic bundle of goods. If a person’s income or total expenditure is not sufficient for her to afford the bundle of goods she is deemed poor.

The non-welfarist approach is more concerned with specific commodity forms of deprivation, such as inadequate food consumption. A food deprivation poverty line would, for example, consider the nutritional value of food consumed, and this is compared with some minimal nutritional requirement. If a person’s nutritional intake is lower than this minimum, that person is deemed poor. This approach requires data on actual food consumption. This is somewhat problematic when using the IES 2000, since the survey only reports on the *value* of food *purchased* and not the *quantities* of food *consumed*. The quality of the poverty analysis therefore depends on the quality of (regional) price indices used to convert values to quantities. Despite these problems some researchers have calculated food poverty lines (see Hoogeveen and Özler, 2004, Woolard and Leibbrandt, 2001).

A relative poverty line is usually defined as a specific percentile of an income or expenditure distribution, i.e. if the ρ^{th} percentile is used it implies that $\rho\%$ of the population is poor. Sometimes the median of per capita income is used, while others have used the 40th percentile of adult equivalent per capita income as a plausible poverty line (see section 3.2.2).

A relative poverty line implies that as the average standard of living increases, the poorest ρ % of the population will still be *relatively* poor compared to the remaining $(1 - \rho)$ % of the population, i.e. “*the poor are always with us*” (Woolard and Leibbrandt, 2001:48).

Poverty measures are usually calculated using the Foster-Greer-Thorbecke (FGT) class of decomposable measures. Foster, Greer and Thorbecke (1984, as cited in Woolard, 1998) proposed a generalised class of decomposable poverty measures. This decomposable poverty measure is flexible in that the same formula can be used to calculate the incidence and depth of poverty, depending on the value of the parameter α . Consider the following formula:

$$P_\alpha = \frac{1}{n} \sum_{i=1}^q \left(\frac{z - y_i}{z} \right)^\alpha$$

The variable y_i is the welfare measure used to measure poverty and is defined over n people in our population, $i = 1, \dots, n$. As mentioned previously poverty measurement requires the selection of some poverty line, represented in the formula by z . If the n individuals in our sample are ranked by their income or welfare measure, the q ‘poor’ individuals are those individuals for who $y_i < z$ for $i = 1, \dots, q$. The remaining individuals are defined as non-poor since $y_i \geq z$ for $i = q+1, \dots, n$.

The parameter α can take on any value greater or equal to one, but in practice $\alpha = 0, 1$ or 2 is most frequently used. These three measures represent the poverty headcount index (P_0), the poverty gap index (P_1) and the poverty gap squared (P_2) respectively. When $\alpha = 0$, P_α simply reduces to $P_0 = q/n$, where q is the number of poor. It thus represents the share of the population that is poor. The headcount index is totally insensitive to the depth of poverty.

When $\alpha = 1$ one is essentially summing the relative poverty gap over all poor households and dividing by the total number of households. This poverty gap index (P_1) measures the ‘depth’ of poverty, as it is a function of both the distance of each poor household from the poverty line and the number of poor. Woolard (1998) points out that P_1 has a number of advantages over P_0 . Since P_0 is discontinuous at the poverty line, a transfer from a very poor household to a just-poor household that enables the just-poor household to escape poverty will reduce the headcount ratio. This is a violation of the Pigou-Dalton condition. Since P_1 is continuous and concave such a transfer will increase the poverty gap index. However, P_1 nevertheless neglects poverty among the poor. A transfer from one poor household to another will have no impact on P_1 , provided the receiving household remains poor after the transfer.

P_2 is also a measure of the depth of poverty. It improves on P_0 and P_1 because it also takes into account the inequality amongst the poor. In fact, it can be shown that P_2 can be decomposed into two components, namely an amount due to the poverty gap, and an amount

due to the inequality among the poor as measured in terms of the coefficient of variation. Thus,

$$P_2 = \frac{(P_1)^2}{P_0} + \frac{(P_0 - P_1)^2}{P_0} (C_q)^2.$$

C_q denotes the coefficient of variation of income among the poor. Woolard (1998) explains that although this breakdown goes partway in explaining the meaning of P_2 , it remains difficult to interpret the measure on its own. One of the advantages of P_2 , however, is that an increase in the measured poverty associated with a fall in the living standard will be deemed greater the poorer the household.

3.2.2. *South African poverty lines*

All income and expenditure data in the IES/LFS 2000, with the exception of labour income data, are only gathered at the household level. In the absence of reliable information about how household income is distributed between household members one usually has to assume a uniform distribution of household income among household members. This implies that each member receives the same per capita household income, and hence if one household member is poor it implies that all the other members of that household are also poor.³

Poverty lines are often expressed as some level of per capita income (or an adjusted per capita measure) below which an individual is poor. One such poverty line that is sometimes used in South Africa is half the mean per capita income. In 2000 the mean per capita income in South Africa was equal to R12,220 per annum (IES/LFS 2000).⁴ If we use 50% of this as a poverty line (R6,110 per annum), approximately 62% of the population live in poverty.⁵

Another per capita poverty line often used, and one that is useful for international comparisons, is the so-called \$1 (or \$2) per day poverty line.⁶ Using Purchasing Power Parity

³ Compelling arguments can be made against the assumption of a uniform distribution of income between household members. Often income earners will spend a greater share of the household income on themselves rather than distributing it equally between non-earning family members. Homemakers and children are typically the ones being neglected in these instances. It is, however, very difficult to apply a single distribution function when one deals with thousands of households in the survey, each with various sources of income and varying numbers of working adults bringing different amounts of income to the household.

⁴ This is different from the 50th percentile or median of per capita income, which is R3812 per annum or R318 per month.

⁵ A similar calculation by Woolard and Leibbrandt (2001) set the 1993 poverty line at R2,422 per annum, which translates to a poverty headcount of 'only' 47% of the population. Comparisons of poverty rates over time are problematic for a number of reasons. Firstly, poverty lines are not always comparable due to inflationary factors and living costs and standards not properly accounted for. Secondly, even if poverty lines were comparable, different datasets (they use the PSLSD dataset, see SALDRU, 1994) and weights may easily lead to different poverty rates. Finally, at the time of conducting the survey political conditions in South Africa prevented such surveys from properly sampling households in former homelands areas or remote rural areas.

⁶ The World Bank's \$1 per day measure is actually estimated as \$1.08 per day.

(PPP) conversion rates Hooegeveen and Özler (2004) estimate the equivalent Rand values in 2000 prices as R87 and R174 per capita per month, which translates to R1,044 and R2,088 per capita per annum for the \$1 and \$2 poverty lines respectively.⁷ Using the IES/LFS 2000 data the \$1 and \$2 per day poverty lines translate to poverty headcount ratios of 10% and 29% of the population, respectively.

Hooegeveen and Özler (2004) also derive what they term ‘upper and lower bound’ poverty lines using the ‘cost of basic needs’ approach. Based on their findings they argue that a reasonable poverty line for South Africa must lie somewhere between R3,864 and R7,116 per capita per annum (2000 prices). Using this range we estimated that between 49% and 66% of the population live in poverty. Despite using the same survey data these estimates are slightly lower than those of Hooegeveen and Özler, mainly due to the adjustments made to our IES 2000 database (see PROVIDE, 2005b for a detailed review of data adjustments made).

Per capita income measures only take into account the size of households without adjusting for the fact that children typically require less spending than their adult counterparts, nor the fact that large households benefit from economies of scale on shared goods such as housing. This ‘deficiency’ of the per capita approach has led to the use of so-called adult equivalence scales to calculate adult equivalent per capita income of households. The equivalence scale adjusts the household size using the equation $E = (A + \alpha K)^\theta$. E is the adjusted household size, A is the number of adults and K the number of children in the household, usually defined as household members under the age of 10. Thus, $H = A + K$ where H is the household size. The parameter α adjusts for the lower expenditure requirement of children, while θ adjusts for economies of scale enjoyed by households. In fact, many poverty lines used today, including the Minimum Living Level (MLL) and the Supplemental Living Level (SLL) of the Bureau for Market Research (University of South Africa), and the Household Subsistence Level of the Institute for Development Planning Research (University of Port Elizabeth) report adult equivalent poverty lines.

A relative poverty line based on adult equivalent income that is used frequently in South Africa is the 40th percentile cut-off of adult equivalent per capita income. Each *household* that earns less than the 40th percentile of adult equivalent per capita income is deemed poor, and by extension each member of a poor household is poor. Setting $\alpha = 0.5$ and $\theta = 0.9$ the 40th percentile cut-off for adult equivalent per capita income is calculated as R5,702.⁸ Households

⁷ Although the exchange rate towards the latter half of 2000 fluctuated between R6.50 and R7.50 to the US Dollar, the 1993 World Bank Purchasing Power Parity (PPP) rate was only R1.672/\$. An average inflation rate of 7% per annum was used to inflate the values to 2000 prices. Thus, $1.08 * 1.672 * (1.07)^7 * 30 = R87$ per capita per month. The latest available PPP conversion rate (2001) is 2.0, which would imply that the \$1 (\$2) per day poverty line for South Africa for 2000 is really closer to R61 (R121) per capita per month (see <http://siteresources.worldbank.org>).

⁸ May (1995) suggested these equivalence scale parameter values as “*plausible*” values for South Africa.

at the lower end of the income scale are typically larger in size than those higher up, and hence the poverty headcount ratio is expected to be more than 40% of the population, although by construction 40% of households are poor. Using this poverty line we estimate that about 53% of the population lives in poverty. The 20th percentile cut-off of adult equivalent per capita income is sometimes used as a relative poverty line below which households are deemed ‘ultra-poor’. This poverty line is equal to R2,903 and translates to a poverty headcount ratio 29%.⁹

Despite good arguments in favour of the use of equivalence scales given evidence of significant differences in size and structure of poor versus non-poor households in South Africa (see Table 1), it is not entirely clear that the ‘adult equivalent approach’ is necessarily better or much different from the ‘per capita approach’. Table 2 compares the identification of the poor under the two approaches. The values in the rows indicate the number of poor/non-poor individuals using an annual per capita poverty line of R3,864, while the values in the columns are based on an annual adult equivalent per capita poverty line of R5,130. The latter poverty line is constructed such that the two poverty lines give the exact same poverty rates. The row and column percentages show the ‘accuracy’ of the two approaches – approximately 97% of people is classified the same under the two approaches.

Table 1: Poverty and household size and structure

	Average number of adults	Average number of children	Average household size	Average adult equivalent household size
Poor	3.73	1.38	5.11	3.76
Non-poor	2.50	0.57	3.07	2.47
<i>All households</i>	<i>2.99</i>	<i>0.90</i>	<i>3.88</i>	<i>2.98</i>

Note: The 40th percentile of adult equivalent per capita income used as poverty line.

⁹ Comparative figures reported by May (1998) indicate that just under 50% of the population live in the poorest 40% of households ranked by adult equivalent income, while 27% of the population lives in the poorest 20% of households.

Table 2: Identification the poor under the ‘per capita’ and ‘adult equivalent’ approaches

		Adult equivalent poverty line of R5,130/annum		
Number of observations		Poor	Non-poor	Total
Per capita poverty line of R3,864/annum	Poor	20,209,726	669,222	20,878,948
	Non-poor	678,767	21,087,881	21,766,647
	Total	20,888,492	21,757,103	42,645,595
	Row percentages			
	Poor	96.8%	3.2%	100.0%
	Non-poor	3.1%	96.9%	100.0%
	Total	49.0%	51.0%	100.0%
	Column percentages			
	Poor	96.8%	3.1%	49.0%
	Non-poor	3.2%	96.9%	51.0%
Total	100.0%	100.0%	100.0%	

Clearly, the classification of individuals does not differ dramatically under the two approaches. However, there are two reasons why the per capita approach is preferred for the analysis here. Firstly, the per capita approach is much simpler in terms of calculations and practical implementation of means testing – policymakers and the general public can relate much better to the idea of per capita incomes than the more complex concept of adult equivalent per capita incomes. It is also easier to use per capita income figures when dealing with inequality measures and calculating transfers to households that will enable them to escape poverty.¹⁰ Secondly, the parameters used in the adult equivalence conversion equation appear to be arbitrary when calculating poverty measures. Although they can be estimated to precision, Woolard and Leibbrandt (2001) find that the poverty profile is fairly insensitive to even large changes in the equivalence scale parameters. As a result there is no clear proof or evidence that the use of equivalence scales adds more value to poverty analysis than a simple per capita transformation. As a result some researchers have reverted back to the use per capita poverty lines (see Hooegeven and Özler, 2004, and Van der Berg *et al.*, 2003).

The choice of poverty line has an important impact on the estimated poverty rate. However, in a comparative static analysis such as this the choice becomes somewhat arbitrary since the focus is on *changes* in poverty rates as a result of policy intervention rather than the *actual level of poverty*. In this study we use the Hooegeven and Özler lower bound poverty line of R3,864 per capita per annum for all further analyses as this represents, in our view, one of the most recent thorough investigations into what a “reasonable” (lower bound) poverty line for South Africa should be (2004:9). Their analysis is also based on the same survey (IES 2000).

¹⁰ This has to do with the problem of attaching income levels to individuals in households. Equivalence scales imply that children require a lower amount of spending than their adult counterparts in the same household. We are therefore dealing with two ‘income levels’ within the same household, yet we only have a single poverty line. A single per capita income attached to each member of the household ensures that each member is equally far from a selected poverty line.

A final point worth mentioning is the choice of survey or sampling weights used in the calculation of poverty rates. The IES 2000 dataset contains household-level weights, while the LFS September 2000 contains person-level weights.¹¹ The household-level weights (variable *weight*) were used for all the calculations in the preceding paragraphs as well as the calculations that follow although we are dealing with person-level data. Essentially this approach now attaches the weight of the head of the household to each household member, while in the person-level dataset some household members may have different weights than those of the household head. As illustrated below the impact of the choice of weight on population estimates and poverty rates is small. The reasoning behind using the household weight variable is that all the household income and expenditure estimates in the SAM as well the population estimates used in the CGE model were obtained from the IES/LFS 2000 household-level database and therefore weighted up using variable *weight*. By continuing the use of variable *weight* all post-simulation population and poverty estimates are fully consistent with the pre-simulation estimates.

Figure 1 compares the estimated poverty rates for various household groups using household- and person-level weights and a poverty line of R3,864 per capita per annum.¹² The person weights generally produce higher poverty rates. The national estimate differs by about 1.3 percentage points (50.3% versus 49.0%). The estimates are also tested for various other disaggregations, first by race and then by province and race. Generally the estimates are very similar, with absolute differences ranging between -1.91 and +1.24 percentage points for the province-race comparison (see bottom graph). In percentage terms some of the lower estimates, especially for the white population, are much larger. Although the choice of weight does have an impact the idea here is to look at changes in poverty rates as a result of certain policy shocks, i.e. the marginal impact is analysed in a comparative static framework. As long as the weight variable used before and after the shock the results will be consistent.

¹¹ The *PROVIDE Project Technical Paper 2005:1* (PROVIDE, 2005b) reports in some detail about the different weights in the dataset as well as the weighting procedures in Stata®.

¹² In the figure WC = Western Cape, EC = Eastern Cape, NC = Northern Cape, FS = Free State, KZ = KwaZulu-Natal, NW = North West, GT = Gauteng, MP = Mpumalanga and LP = Limpopo.

Figure 1: Comparison of estimated poverty rates using different sampling weights

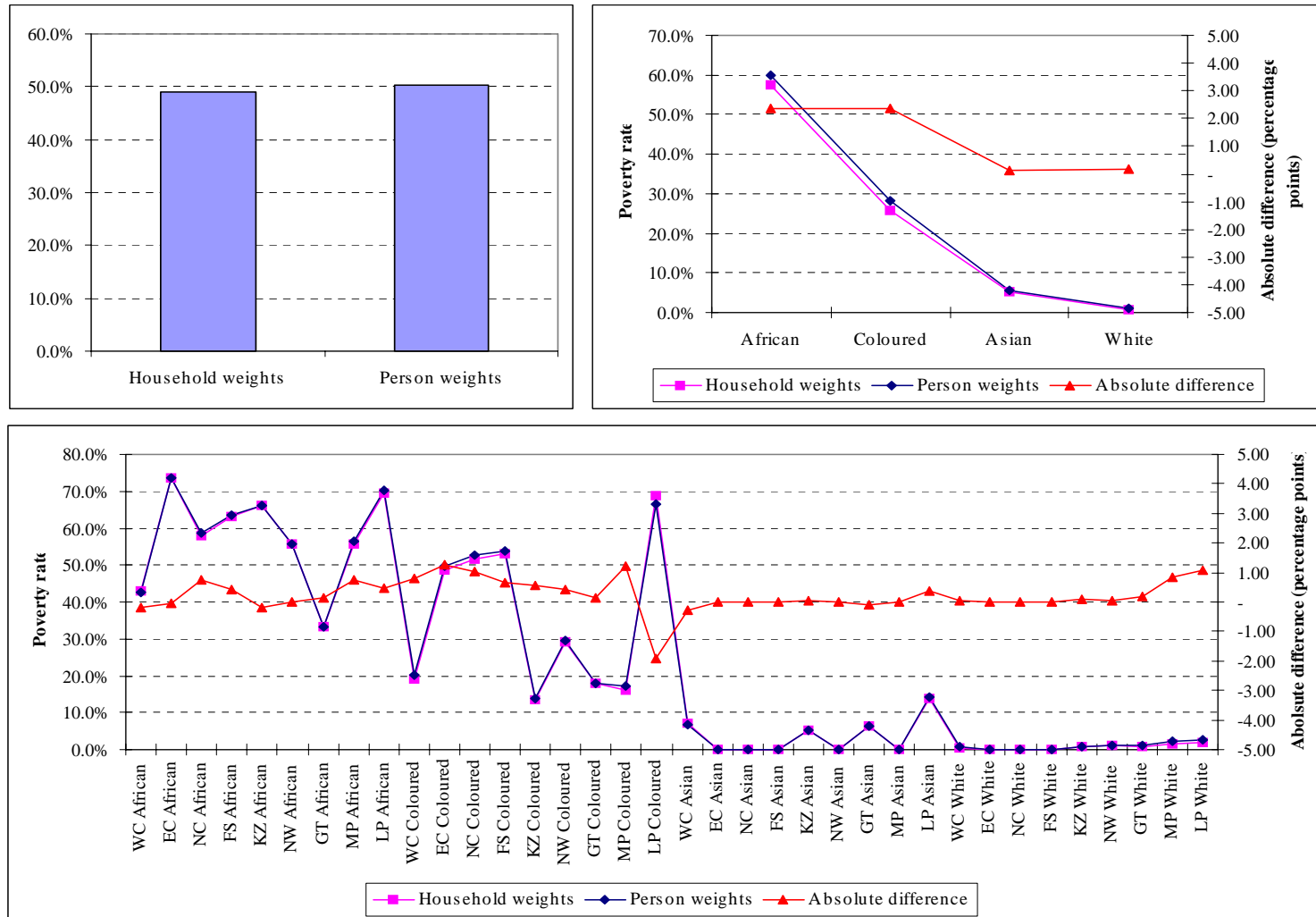

3.2.3. A poverty profile for South Africa

The previous section reported on national average poverty rates in South Africa. However, given the inequalities that exist in South Africa between different representative household groups in different racial groups or spatial locations it is useful to disaggregate these poverty rates further to identify which groups are most disadvantaged. All poverty estimates here are based on a poverty line of R3,864 per capita per annum using household weights. As shown previously (Table 2) an estimated 20.9 million out of 42.6 million (49%) of South Africans are classified as poor. The average per capita income of poor people was R1,934 in 2000, compared to R22,086 for the average non-poor person. This large difference points at the high degree of inequality in South Africa. As mentioned previously the national average per capita income was R12,220. All the tables and figures relating to the discussion that follows below are added as an appendix (section 9.2).

Given past inequalities in South Africa poverty is driven mainly by poverty among Africans, and to a lesser extent Coloureds and Asians (Table 12). Almost 95% of the poor are African, while Africans are also the poorest on average with a poverty rate of 58%. 26% of Coloureds and 5% of Asians are classified as poor. Relatively speaking there are virtually no poor Whites in South Africa.

Poverty rates differ substantially between provinces (see Table 13). The Western Cape and Gauteng provinces have the lowest poverty rates (22% and 28% respectively). Only the Northern Cape (47%) joins them as provinces with poverty rates below the national average of 49%. The Eastern Cape and Limpopo provinces have the highest rates (both about 69%). In fact, more than one third of the poor live in these two provinces (36%). KwaZulu-Natal with a poverty rate of 58% and home to about one quarter of the poor is also hard hit by poverty. All the other provinces have poverty rates of around 50% to 60%. Table 14 shows the poverty rates by region. Not surprisingly the West Coast region has the lowest average rate (25%), while the Central region, which includes Gauteng, has an average poverty rate of 37%. The Border and East Coast regions have much larger poverty rates, both averaging about 62%.

Poverty is often a rural phenomenon. Urban areas are fairly loosely defined in the IES 2000 as any built-up area. This definition thus includes small towns, secondary cities as well as large metropolitan areas. Using the OHS 1995 dataset Woolard (1998) finds that poverty rates are “*unambiguously highest in small towns, followed by secondary cities and lowest¹³ in metropolitan areas*” for a wide range of poverty lines. It is therefore useful to make some kind of a distinction between metropolitan areas and other urban areas. In Table 15 urban and rural

¹³ In the original text Woolard wrote “...and *highest* in metropolitan areas”. Judging by the accompanying figure in her article this was done inadvertently and hence corrected in the quotation here to avoid confusion.

poverty rates and shares are shown, while Table 16 splits urban areas further into urban and metropolitan areas. The *PROVIDE Project Technical Paper 2005:2* (PROVIDE, 2005c) explains in more detail how the mapping was done as well as which metropolitan municipalities were included in the definition of metropolitan. The tables suggest that poverty rates are well below the national average in metropolitan areas (27%). The poverty rate in other urban areas is about 39%, which gives an average for all non-rural areas of 32% (Table 15). The poverty rate is significantly higher in rural areas (73%).

During the 1960s and 70s the South African government, as part of their apartheid policy, set aside various areas known as homelands (see Table 17 and Table 18). The homelands would typically be made up of Africans of a specific ethnic group, depending on the geographic positioning and dominant ethnic group of the region. Homelands were either partially self-governed or in some cases independent from the Republic. The former homelands cover an area of less than 13% of the total land area of South Africa, but are still today home to 33% of the population. Given decades of under funding, poor management, and economic and geographical isolation, the homelands areas typically have a poor infrastructure and a high incidence of poverty and unemployment. The *PROVIDE Project Technical Paper 2005:2* (PROVIDE, 2005c) gives an overview of where these areas are located as well as how they were mapped to the IES/LFS 2000 database.

Of the ten homelands areas identified the Transkei is the largest both in terms of area and the number of inhabitants (3.7 million). However, it is also the poorest with an average per poverty rate of 82%. Transkei is followed closely by KwaZulu with a poverty rate of 77%. The remaining homelands areas all have poverty rates in excess of 60%, with the exception of Bophuthatswana with a poverty rate of ‘only’ 49% despite this homeland being fragmented across South Africa (this would have affected governance in the past). This homeland’s relative fortune can possibly be ascribed to the fact that many hotels and casinos were built here during the apartheid years when gambling was illegal in South Africa. This has always ensured a consistent source of revenue for the government, investment in infrastructure, and job opportunities for its inhabitants. Taken as a whole the former homelands areas have an average poverty rate of 72% compared to only 37% in the rest of South Africa. The inhabitants of homelands are virtually without exception African. It is further interesting to note that the poverty rate among Africans living in non-homelands areas is only 47% (not in the tables).

Table 19 to Table 22 show poverty rates by gender, by age group (children under 15, and adults), by gender of the household head, and by education level of the household head. Firstly we note that poverty is higher among females (51%) than males (46%). The poverty rate among children is also significantly higher than among adults (61% compared to 43%),

which is related to fact that poor households typically have relatively more children than non-poor households (see Table 1). Also interesting to note are differences in poverty rates between different household ‘types’ as defined by the gender and educational attainment of the household head. The poverty rate among individuals living in female-headed households is 64%, compared to only 38% among male-headed households. Educational attainment of the household head is also important, and less education typically means higher poverty rates. The poverty rate in households where the head has no education is a staggering 76%, compared to virtually no poverty among households where the head has a tertiary education (1%).

3.3. Inequality

Although the main focus of this paper is on poverty, the issue of inequality cannot be left untouched. Despite South Africa’s official status as an upper middle-income country it is characterised by extreme degrees of inequality in the distribution of income, assets and opportunities. Past discriminatory policies have left a large proportion of the population outside the economic mainstream, living in circumstances similar to those of the poor in typical third world countries. At the other end of the income spectrum is a small minority group that controls the country’s productive assets, allowing them to enjoy a standard of living comparable to the wealthy in developed countries.

The *PROVIDE Project Working Paper 2005:3* (PROVIDE, 2005f) evaluates in some detail the inequality that exists in South Africa. One of the areas explored in that paper is how overall inequality, as measured by the Gini coefficient, is driven by inequalities in the distribution of specific income components, such as income from labour (wages and salaries) or income from ‘gross operating surplus’. This paper is more concerned with a decomposition of income inequality into within and between-group inequality measures. The Theil-T or Theil-L inequality measures are useful in this regard as such decompositions are possible.¹⁴ These measure are very different from other inequality measures and are derived from the notion of entropy in information theory (PROVIDE, 2003a, PROVIDE, 2005f). Estudillo (1997) uses the following formulas, where y_i is the welfare measure (income), n the population size and μ the population mean of income:

$$T = \frac{1}{n} \sum_{i=1}^n \frac{y_i}{\mu} \ln \left(\frac{y_i}{\mu} \right) \text{ and } L = \frac{1}{n} \sum_{i=1}^n \ln \left(\frac{\mu}{y_i} \right).$$

The household group classification of the PROVIDE SAM (see section 9.1) groups households (and hence by extension individuals) by province (region), race, gender of the head of the household and educational attainment of the head of the household. The large

¹⁴ Various other inequality measures are discussed in PROVIDE (2003b).

difference in poverty rates between different racial groups (Table 12), different regions (Table 14), male and female-headed households (Table 21), and members of households grouped according to the educational attainment of the household head (Table 22) suggest that inequalities between these groups are also likely to be large. Leibbrandt *et al.* (2001b) show that the Theil-T (T) and Theil-L (L) measures can be decomposed as

$$T = T_B + \sum_{i=1}^n q_i T_i \quad \text{and} \quad L = L_B + \sum_{i=1}^n p_i L_i,$$

where the component T_B (L_B) is the between-group contribution and is calculated in the same way as T (L) but assumes that all incomes within a group are equal. T_i (L_i) is the Theil inequality measure within the i^{th} group, while q_i (p_i) is the weight attached to each within-group inequality measure. When the Theil-T is used the weight is the proportion of income accruing to the i^{th} group, while for Theil-L it is the proportion of the population falling within that group.

Table 3 shows the results of these decompositions by region, race, gender of the head of the household and educational attainment of the head of the household. As was the case with the poverty analysis in the previous section the welfare measure used here is per capita income (2000 prices). Measured by its per capita income the West Coast region is the most affluent of all the regions (R19,769). The Central region follows with R16,011, while the East Coast and Border regions are much worse off with average per capita incomes of R8,471 and R7,155 respectively. The Theil-L and Theil-T measures rank these regions differently in terms of inequality, and as a result it is difficult to say which groups contribute most to the overall within-group inequality. However, in both the Theil-L and Theil-T approaches the East Coast and Central regions appear to be driving much of the inequality. The between group inequality is, interestingly so, quite small, despite fairly large differences in average per capita incomes and poverty rates in these regions. As a result the within-group component drives about 93% of the overall inequality in South Africa.

The racial analysis points at an interesting trend that has been developing over the past few years in South Africa, namely that of increasing inequality among African individuals. Inequality is highest among this group. In the Theil-L decomposition population weights are used, and this then suggests that African inequality contributes 86% to overall within-group inequality. However, under the Theil-T approach where income shares are used as weights, White inequality becomes much more important, contributing 31% to overall within-group inequality. However, even under this approach African inequality still contributes 58% to overall within-group inequality. As a whole within-group inequality, perhaps surprisingly so, contributes more to overall inequality than between-group inequality. However, the between-group component is still relatively high given South Africa's historical policies of

discrimination. The legacy of apartheid is clear when looking at average per capita incomes – Africans only earn R7,020 per capita per annum, compared to R12,616 for Coloureds, R22,966 for Asians, and R61,058 for Whites.

The decomposition for household groups based on the gender of the head of the household suggests that most of the within-group inequality is driven by male-headed inequality (64% - 80%), while between 90% and 92% of overall inequality is explained by overall within-group inequality. The between-group component again contributes surprisingly little to overall inequality, despite the fact that members of male-headed households have a per capita income of R16,538 compared to R6,402 for members of female-headed households.

When the educational attainment of the household head is used as the basis it results in an interesting decomposition. Although not conclusive, it appears as if inequality is highest among those where the household head has an upper secondary (grade twelve) qualification. Here the population and income share weights are important and drive the contribution of each group to overall within-group inequality. Approximately one third of individuals live in households where the household head only has a primary school education, and hence under the Theil-L approach this contributes the largest share (30%) to overall within-group inequality. However, under the Theil-L approach members of households where the head has an upper secondary education earn the largest share of national income, and as a result they contribute the largest share (40%) to overall within-group inequality. This is despite the fact that the average per capita income in this group is nowhere near that of individuals living in households where the head has a tertiary income. These per capita figures are R3,799 for no education, R5,134 for primary school, R9,667 for lower secondary, R24,926 for upper secondary and R67,963 for tertiary. Despite these fairly large differences in average per capita incomes, the between-group inequality only contributes slightly over 40% to overall inequality.

Table 3: Theil inequality measure: within and between group decomposition

	Group-specific Theil-L (L_i)	Pop share (p_i)	Contribution to within-group inequality ($p_i L_i$)	Shares	Group-specific Theil-L (T_i)	Pop share (q_i)	Contribution to within-group inequality ($q_i T_i$)	Shares
By Region								
West Coast	0.79	0.11	0.08	10%	0.85	0.17	0.15	15%
East Coast	0.94	0.36	0.34	38%	1.13	0.25	0.28	28%
Border	0.77	0.17	0.13	15%	0.91	0.10	0.09	9%
Central	0.90	0.37	0.33	37%	0.97	0.48	0.46	47%
Within-group (*)			0.88	93%			0.98	93%
Between-group (L_B / T_B)			0.07	7%			0.07	7%
Theil-L / Theil-T			0.95				1.05	
By Race								
African	0.69	0.81	0.56	86%	0.80	0.46	0.37	58%
Coloured	0.52	0.09	0.05	7%	0.54	0.09	0.05	8%
Asian	0.43	0.02	0.01	2%	0.43	0.05	0.02	3%
White	0.42	0.08	0.03	5%	0.49	0.40	0.20	31%
Within-group (*)			0.65	68%			0.63	60%
Between-group (L_B / T_B)			0.30	32%			0.42	40%
Theil-L / Theil-T			0.95				1.05	
By Gender of Head								
Male-headed	0.93	0.58	0.54	64%	0.98	0.78	0.77	80%
Female-headed	0.75	0.42	0.31	36%	0.90	0.22	0.20	20%
Within-group (*)			0.85	90%			0.96	92%
Between-group (L_B / T_B)			0.10	10%			0.09	8%
Theil-L / Theil-T			0.95				1.05	
By Education of Head								
No educ/unknown	0.51	0.23	0.12	20%	0.66	0.07	0.05	8%
Primary	0.53	0.32	0.17	30%	0.60	0.13	0.08	13%
Lower secondary	0.59	0.23	0.13	24%	0.63	0.18	0.11	18%
Upper Secondary	0.66	0.18	0.12	22%	0.65	0.38	0.24	40%
Tertiary	0.47	0.04	0.02	4%	0.52	0.24	0.13	21%
Within-group (*)			0.56	59%			0.61	58%
Between-group (L_B / T_B)			0.39	41%			0.44	42%
Theil-L / Theil-T			0.95				1.05	

Note (*): Within-group component calculated as $\sum_{i=1}^n p_i L_i$ or $\sum_{i=1}^n q_i T_i$, where n refers to the population subgroups, e.g. racial groups.

4. Model and data

4.1. Model description

The computable general equilibrium (CGE) model (see PROVIDE, 2005e) is a member of the class of single country computable general equilibrium (CGE) models that are descendants of

the approach to CGE modeling described by Dervis *et al.* (1982). More specifically, the implementation of this model, using the GAMS (General Algebraic Modeling System) software, is a direct descendant and development of models devised in the late 1980s and early 1990s, particularly those models reported by Robinson *et al.* (1990), Kilkenny (1991) and Devarajan *et al.* (1994). The model is a SAM based CGE model, wherein the SAM serves to identify the agents in the economy and provides the database with which the model is calibrated. The SAM also serves an important organisational role since the groups of agents identified by the SAM structure are also used to define sub-matrices of the SAM for which behavioural relationships need to be defined. As such the modelling approach has been influenced by Pyatt's 'SAM Approach to Modeling' (Pyatt, 1998).

The description of the model here is necessarily brief and proceeds in two stages. The first stage is the identification of the behavioural relationships; these are defined by reference to the sub matrices of the SAM within which the associated transactions are recorded. The second stage uses a pair of figures to explain the nature of the price and quantity systems for commodity and activity accounts that are embodied within the model.

4.1.1. *Behavioural Relationships*

While the accounts of the SAM determine the agents that can be included within the model, and the transactions recorded in the SAM identify the transactions that took place, the model is defined by the behavioural relationships. The behavioural relationships in this model are a mix of non-linear and linear relationships that govern how the model's agents will respond to exogenously determined changes in the model's parameters and/or variables. Table 4 summarises the model relationships by reference to the sub matrices of the SAM.

Households are assumed to choose the bundles of commodities they consume so as to maximise utility where the utility function is a Stone-Geary function that allows for subsistence consumption expenditures, which is an arguably realistic assumption when there are substantial numbers of very poor consumers. The households choose their consumption bundles from a set of 'composite' commodities that are aggregates of domestically produced and imported commodities. These 'composite' commodities are formed as Constant Elasticity of Substitution (CES) aggregates that embody the presumption that domestically produced and imported commodities are imperfect substitutes. The optimal ratios of imported and domestic commodities are determined by the relative prices of the imported and domestic commodities. This is the so-called Armington assumption (Armington, 1969), which allows for product differentiation via the assumption of imperfect substitution (see Devarajan *et al.*, 1994). The assumption has the advantage of rendering the model practical by avoiding the extreme specialisation and price fluctuations associated with other trade assumptions. In this model the country is assumed to be a price taker for all imported commodities.

Domestic production uses a two-stage production process. In the first stage aggregate intermediate and aggregate primary inputs are combined using CES technology. Hence aggregate intermediate and primary input demands vary with the relative prices of aggregate intermediate and primary inputs. At the second stage intermediate inputs are used in fixed proportions relative to the aggregate intermediate input used by each activity. The ‘residual’ prices per unit of output after paying for intermediate inputs, the so-called value added prices, are the amounts available for the payment of primary inputs. Primary inputs are combined to form aggregate value added using CES technologies, with the optimal ratios of primary inputs being determined by relative factor prices. The activities are defined as multi-product activities with the assumption that the proportionate combinations of commodity outputs produced by each activity/industry remain constant; hence for any given vector of commodities demanded there is a unique vector of activity outputs that must be produced. The vector of commodities demanded is determined by the domestic demand for domestically produced commodities and export demand for domestically produced commodities. Using the assumption of imperfect transformation between domestic demand and export demand, in the form of a Constant Elasticity of Transformation (CET) function, the optimal distribution of domestically produced commodities between the domestic and export markets is determined by the relative prices on the alternative markets. The model can be specified as a small country, i.e., price taker, on all export markets, or selected export commodities can be deemed to face downward sloping export demand functions, i.e., a large country assumption. The other behavioural relationships in the model are generally linear.

Table 4: Relationships for the Computable General Equilibrium Model

	Commodities	Activities	Factors	Households	Enterprises	Government	Capital	RoW	Total	Prices
Commodities	0	Leontief Input-Output Coefficients	0	Utility Functions (Stone-Geary or CD)	Fixed in Real Terms	Fixed in Real Terms and Export Taxes	Fixed Shares of Savings	Commodity Exports (CET)	Commodity Demand	Consumer Commodity Price Prices for Exports
Activities	Domestic Production	0	0	0	0	0	0	0	Constant Elasticity of Substitution Production Functions	
Factors	0	Factor Demands (CES)	0	0	0	0	0	Factor Income from RoW	Factor Income	
Households	0	0	Fixed Shares of Factor Income	Fixed (Real) Transfers	Fixed (Real) Transfers	Fixed (Real) Transfers	0	Remittances	Household Income	
Enterprises	0	0	Fixed Shares of Factor Income	0	0	Fixed (Real) Transfers	0	Transfers	Enterprise Income	
Government	Tariff Revenue Export Taxes Commodity Taxes	Indirect Taxes on Activities Factor Use Taxes	Factor Income Taxes Fixed Shares of Factor Income	Direct Taxes on Household Income	Direct Taxes on Enterprise Income	0	0	Transfers	Government Income	
Capital	0	0	Depreciation	Household Savings	Enterprise Savings	Government Savings (Residual)	0	Current Account 'Deficit'	Total Savings	
Rest of World	Commodity Imports	0	Fixed Shares of Factor Income	0	0	0	0	0	Total 'Expenditure' Abroad	
Total	Commodity Supply (Armington CES)	Activity Input	Factor Expenditure	Household Expenditure	Enterprise Expenditure	Government Expenditure	Total Investment	Total 'Income' from Abroad		
	Producer Commodity Prices Domestic and World Prices for Imports	Value Added Prices								

The model is set up with a range of flexible closure rules. The specific choices about closure rules used in this study are defined in the Policy Analysis section below.

4.1.2. Price and Quantity Relationships

Figure 2 and Figure 3 provide an overview of the interrelationships between the prices and quantities. The supply prices of the composite commodities (PQS_c) are defined as the weighted averages of the domestically produced commodities that are consumed domestically (PD_c) and the domestic prices of imported commodities (PM_c), which are defined as the products of the world prices of commodities (PWM_c) and the exchange rate (ER) uplifted by *ad valorem* import duties (tm_c). These weights are updated in the model through first order conditions for optima. The supply prices exclude sales, excise and fuel taxes, and hence must be uplifted by (*ad valorem*) sales taxes (ts_c), excise taxes (tex_c) and fuel taxes ($tfue_c$) to reflect the composite consumer price (PQD_c). The producer prices of commodities (PXC_c) are similarly defined as the weighted averages of the prices received for domestically produced commodities sold on domestic and export (PE_c) markets; the weights are updated in the model through first order conditions for optima. The prices received on the export market are defined as the products of the world price of exports (PWE_c) and the exchange rate (ER) less any exports duties due, which are defined by *ad valorem* export duty rates (te_c).

The average price per unit of output received by an activity (PX_a) is defined as the weighted average of the domestic producer prices, where the weights are constant. After paying indirect/production/output taxes (tx_a), this is divided between payments to aggregate value added (PVA_a), i.e., the amount available to pay primary inputs, and aggregate intermediate inputs ($PINT_a$). The factor prices paid by activities ($WF_{f,a}$) constitute the components of value added, while total payments for intermediate inputs per unit of aggregate intermediate input are defined as the weighted sums of the prices of the inputs (PQD_c).

Figure 2: Price Relationships for a Standard Model with Commodity Exports

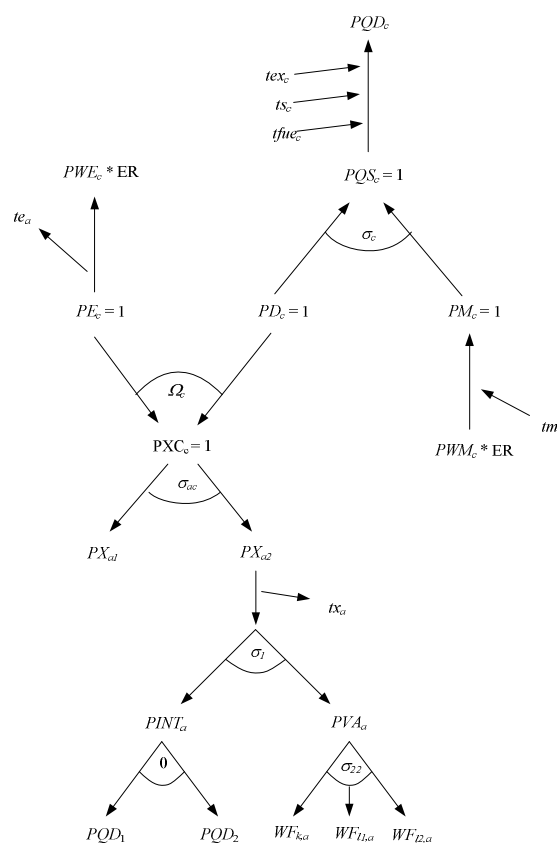

Total demands for the composite commodities, QQ_c , consist of demands for intermediate inputs, $QINTD_c$, consumption by households, QCD_c , enterprises, $QENTD_c$, and government, QGD_c , gross fixed capital formation, $QINVD_c$, and stock changes, $dstocconst_c$. Supplies from domestic producers, QD_c , plus imports, QM_c , meet these demands; equilibrium conditions ensure that the total supplies and demands for all composite commodities equate. Commodities are delivered to both the domestic and export, QE_c , markets subject to equilibrium conditions that require all domestic commodity production, QXC_c , to be either domestically consumed or exported.

The multi product activities are modelled using the assumption that commodities are differentiated by (source) activity but that activities produced outputs in fixed proportions.¹⁵ Hence the domestic production of a commodity (QXC_c) is a CES aggregate of the quantities of that commodity produced by a number of different activities ($QXAC_{a,c}$), which are produced by each activity in activity specific fixed proportions, i.e., the output of $QXAC_{a,c}$ is a Leontief (fixed proportions) aggregate of the output of each activity (QX_a).

¹⁵ The model allows for the imposition of the alternative assumption that the ‘same’ commodities produced by different activities are homogenous.

Figure 3: Quantity Relationships for a Standard Model

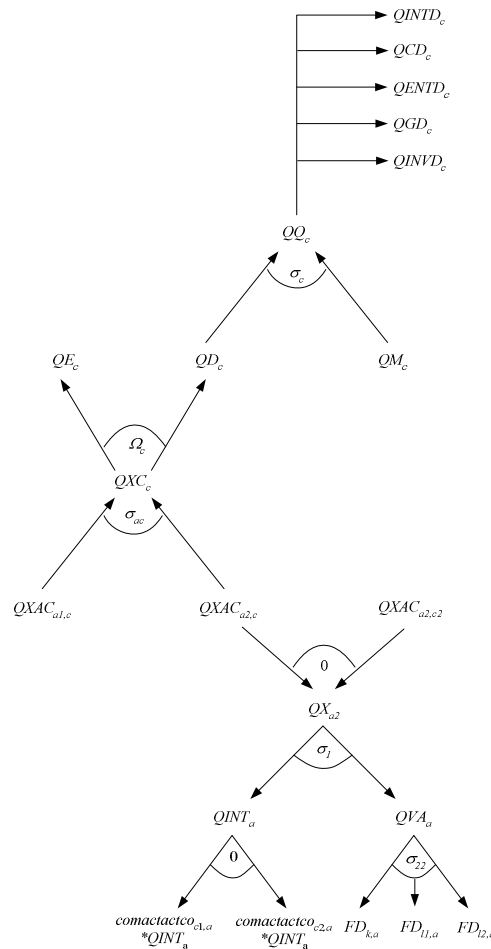

Production relationships by activities are defined by a series of nested Constant Elasticity of Substitution (CES) production functions. The nesting structure is illustrated in lower part of Figure 2, where, for illustration purposes only, two intermediate inputs and three primary inputs ($FD_{k,a}$, $FD_{l1,a}$ and $FD_{l2,a}$) are identified. Activity output is a CES aggregate of the quantities of aggregate intermediate inputs ($QINT_a$) and value added (QVA_a), while aggregate intermediate inputs are a Leontief aggregate of the (individual) intermediate inputs and aggregate value added is a CES aggregate of the quantities of primary inputs demanded by each activity ($FD_{f,a}$). The allocation of the finite supplies of factors (FS_f) between competing activities depends upon relative factor prices via first order conditions for optima. While the base model contains the assumption that all factors are fully employed and mobile this assumption can be relaxed.

4.2. Social Accounting Matrix

The primary benchmark data used to calibrate the CGE model is arranged in the form of a Social Accounting Matrix (SAM), which is a system of accounts recording all transactions

between agents in the economy. The SAM is a 309-account aggregation of the PROVIDE SAM for South Africa in 2000 (see PROVIDE, 2005a for a full description of the South African SAM). The model SAM has 32 commodities, 39 activities, 56 factors, including GOS (capital), nine land factors (one for each province) and 46 labour factors. The model SAM uses the fully disaggregated 162 household accounts of the PROVIDE SAM (see sections 5.2 and 9.1). There are also accounts for taxes, enterprises, the government, savings and investment, and an account for international transactions (rest-of-world). A full listing of the accounts for this study is given in the appendix (section 9.4).

5. Simulation setup

5.1. Overview

A series of ten simulations are run under a variety of different model closures. In each simulation a set amount of funds is transferred to each member of a targeted representative household group. This transfer takes place over and above existing transfers from government to these to households. The total transfer value is limited to R15bn per annum, hence the higher the transfer per capita the fewer individuals receive the transfer. In simulations one to five (labelled *sim01* to *sim05*) each member of a targeted household group receives R40, R60, R80, R100 and R120 per month respectively. Simulations six to ten (labelled *sim06* to *sim10*) repeat the R40 to R120 per capita per month simulations, but now assume that government incurs an administration fee equal to 25% of the total value of the increase in transfers. The targeting of households is discussed in section 5.2, while model closures are discussed in section 5.3. Section 5.4 concludes with some comments about the model setup, limitations and assumptions that are of importance for interpreting the simulations.

5.2. Targeting representative household groups

The representative household groups in the PROVIDE SAM are formed around province, race, gender of the head of the household and educational attainment of the head of the household. These sub-groups are characterised by large differences in poverty rates (see section 3.2.3). A brief description of the household group disaggregation is provided in the appendix (section 9.1). Targeting is based on two basic assumptions: firstly, the total value of the transfer is limited to R15 billion per annum due to some hypothetical budget constraint,¹⁶ and, secondly, household groups with the highest poverty rates receive transfers first until the budget is depleted. Thus, for low transfer values many household groups can be targeted and

¹⁶ The budget constraint is strictly set at R15 billion or less, i.e. a household group that causes the budget to exceed R15 billion cannot be added. In order to maintain the transfer value at R15bn the actual per capita transfer amount is adjusted slightly in each simulation. Therefore, the exact transfer amounts are actually R42, R61, R81, R104 and R122 per capita per month for the various simulations.

vice versa. The aim of the simulations is to evaluate the trade-off between broad targeting and narrow targeting given a budget constraint. Given the way in which household groups were constructed each household group contains poor and non-poor households. This implies that if a household group is targeted for transfers both poor and non-poor members of the household group will receive the transfer. This is a consequence of the top down approach adopted. An alternative bottom up approach would have required the calculation of the transfers by reference to the individual households in the survey and then grossing up the transfer for each representative household group. Of course the bottom up approach implies that there is some form of comprehensive means testing that ensures 'perfect' targeting, but that would be expensive to implement. However, as shown below the proportion of non-poor in targeted households is not extremely high and declines as the target group is narrowed.

According to the IES/LFS 2000 estimates South Africa had a population of 42.6 million people in 2000. Using a poverty line of R3,864 per capita per annum approximately 20.9 million people or 49% of the population are regarded as poor. Figure 4 shows the number of recipients under each simulation. For a R40 per capita transfer value 95 household groups across South Africa and a total population of about 29.8 million are reached. Of these 19.7 million are poor, i.e. two poor persons receives the transfer for every one non-poor person that receives a transfer (the ratio of the poor and non-poor components of the bars in the graph). Approximately 94% of the poor are reached in this simulation (line graph). However, at a transfer value of R480 per capita per annum it only brings the poor marginally closer to the poverty line of R3,864 per annum, while about a third of the transfer is 'lost' by transferring it to non-poor individuals.

The figure clearly shows how the number of targeted individuals falls as the transfer value increases, while the ratio of poor to non-poor increases in favour of the poor. However, as shown by the line graph the proportion of the poor reached also declines as the transfer becomes more and more targeted at the very poor household groups. At a transfer value of R120 per capita only 42% of the poor are reached. A total of 10.2 million individuals are targeted of which only 1.4 million (14%) are classified as non-poor.

Figure 4: The trade-off between transfer value and the number of recipients

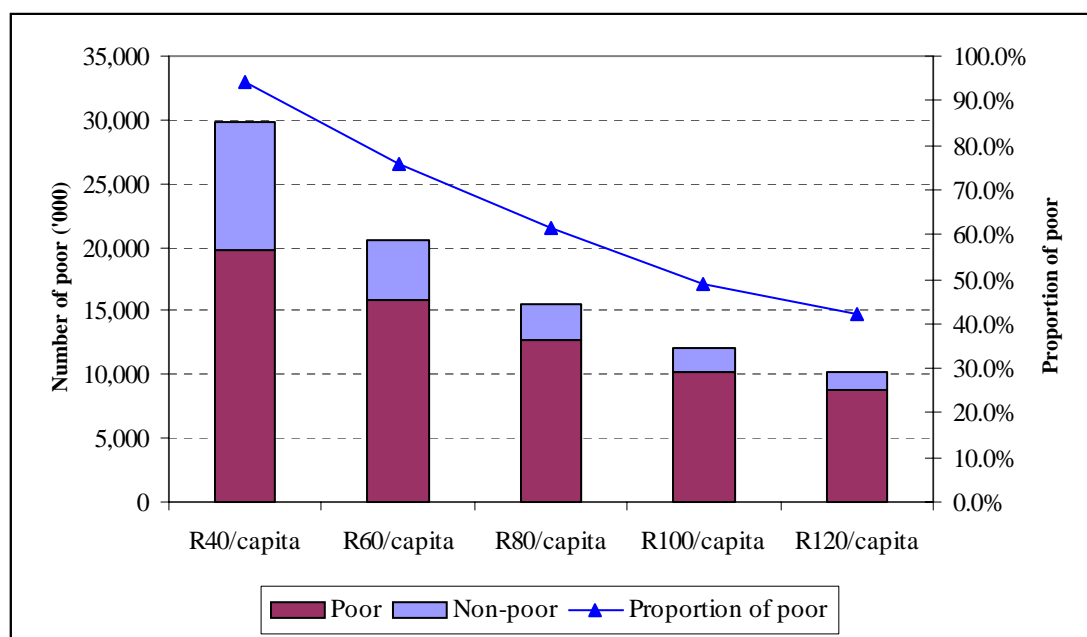

Below we consider in more detail poverty rates and targeting of households within each of the four PROVIDE regions. All population and income/expenditure estimates are based on the Income and Expenditure Survey of 2000 and the Labour Force Survey of September 2000 conducted by Statistics South Africa (SSA, 2002a, SSA, 2002b). Much of the summary statistics are presented in more detail in the series of *PROVIDE Project Background Papers 2005:1 (Volumes 1-10)* (PROVIDE, 2005d).

5.2.1. West Coast region

The West Coast region includes the Western and Northern Cape provinces. The Western Cape province is home to about 10% of South Africa’s population. Measured by its total current income, the Western Cape is the second richest province in South Africa after Gauteng, while in *per capita* income terms the province also ranks second after Gauteng. Roughly 52% of the households in the province are classified as Coloured, while Africans and Whites make up 24% and 23% respectively. Asian households only account for 1% of the population. The 1.05 million households (3.99 million people) are grouped into 16 household groups. Of these groups four are African, eight are Coloured/Asian and five are White. As in many of the other provinces Asian and Coloured households were merged due to the small number of Asian and/or Coloured households.

The Northern Cape province is home to only 1.8% of South Africa’s population. Measured by its total current income, the Northern Cape has the lowest total income of all provinces in South Africa. In *per capita* income terms, however, the province ranks third after Gauteng and the Western Cape. As with the Western Cape, Coloured households make up the largest

group (46%), while African and White account for 37% and 17% of households respectively. There are virtually no Asian households. Since there are only 187,247 households and a total population of 865,321 people, only five household groups were formed. The Coloured/Asian and African sub-groups are both disaggregated into two education groups, while White households are grouped together as a single household group.

The average per capita income in the Western Cape was R20,275 in 2000, almost twice as much as the national average of R12,220. In comparison the average per capita income in the Northern Cape was R16,4735. These provinces have a joint poverty rate of 25%, which is well below the national average (49%). The region accounts for less than 6% of the poor in South Africa (see Table 14). Since the simulations rank household groups according to their poverty rates nationally few West Coast household groups are included in the simulations (see Table 5). In fact, none are included in simulations three to five. The targeted household groups are all African and Asian/Coloured, typically with low levels of education. About 85% of the poor in the region are reached in simulation one, and 33% in simulation two (see note at the bottom of the table).

Table 5: Poverty rates and targeted household groups in the West Coast region

GAMS code	Description	FGT poverty indices			Population estimates				Targeting (1 = YES)				
		P ₀	P ₁	P ₂	Population size	Share of population (within region)	Number of poor	Share of the poor (within region)	R40/capita	R60/capita	R80/capita	R100/capita	R120/capita
HWC1	WC African, Female, Lower Secondary and lower	0.581	0.210	0.100	286,712	6.3%	166,642	14.4%	1	1	0	0	0
HWC2	WC African, Male, Primary and lower	0.492	0.185	0.094	317,393	6.9%	156,100	13.5%	1	0	0	0	0
HWC3	WC African, Male, Lower Secondary	0.279	0.098	0.047	163,828	3.6%	45,720	3.9%	1	0	0	0	0
HWC4	WC African, Upper Secondary and higher	0.191	0.063	0.030	161,825	3.5%	30,855	2.7%	0	0	0	0	0
HWC5	WC Asian & Coloured, Female, Primary and lower	0.337	0.129	0.062	392,351	8.6%	132,358	11.4%	1	0	0	0	0
HWC6	WC Asian & Coloured, Female, Lower Secondary	0.212	0.064	0.029	184,473	4.0%	39,165	3.4%	0	0	0	0	0
HWC7	WC Asian & Coloured, Female, Upper Secondary and higher	0.052	0.030	0.021	79,000	1.7%	4,116	0.4%	0	0	0	0	0
HWC8	WC Asian & Coloured, Male, Primary and lower	0.265	0.079	0.034	651,496	14.2%	172,430	14.9%	1	0	0	0	0
HWC9	WC Asian & Coloured, Male, Lower Secondary	0.137	0.051	0.025	616,010	13.5%	84,235	7.3%	0	0	0	0	0
HWC10	WC Asian & Coloured, Male, Upper Secondary and higher, Low-income (split)	0.097	0.034	0.016	178,671	3.9%	17,326	1.5%	0	0	0	0	0
HWC11	WC Asian & Coloured, Male, Upper Secondary and higher, High-income (split)	0.000	0.000	0.000	254,293	5.6%	0	0.0%	0	0	0	0	0
HWC12	WC White, Lower Secondary and lower	0.028	0.013	0.006	106,587	2.3%	2,999	0.3%	0	0	0	0	0
HWC13	WC White, Upper Secondary, Low-income (split)	0.000	0.000	0.000	115,248	2.5%	0	0.0%	0	0	0	0	0
HWC14	WC White, Upper Secondary, High-income (split)	0.000	0.000	0.000	190,767	4.2%	0	0.0%	0	0	0	0	0
HWC15	WC White, Tertiary, Low-income (split)	0.000	0.000	0.000	104,371	2.3%	0	0.0%	0	0	0	0	0
HWC16	WC White, Tertiary, High-income (split)	0.000	0.000	0.000	118,774	2.6%	0	0.0%	0	0	0	0	0
HNC1	NC African, Primary and lower	0.671	0.292	0.159	147,274	3.2%	98,830	8.5%	1	1	0	0	0
HNC2	NC African, Lower Secondary and higher	0.418	0.181	0.100	85,764	1.9%	35,861	3.1%	1	0	0	0	0

Table 5 continued...

GAMS code	Description	FGT poverty indices			Population estimates				Targeting (1 = YES)				
		P ₀	P ₁	P ₂	Population size	Share of population (within region)	Number of poor	Share of the poor (within region)	R40/capita	R60/capita	R80/capita	R100/capita	R120/capita
HNC3	NC Coloured & Asian, Lower Secondary and lower	0.591	0.268	0.156	201,079	4.4%	118,847	10.3%	1	1	0	0	0
HNC4	NC Coloured & Asian, Upper Secondary and higher	0.396	0.171	0.092	133,820	2.9%	52,931	4.6%	1	0	0	0	0
HNC5	NC White	0.000	0.000	0.000	86,635	1.9%	0	0.0%	0	0	0	0	0
-	West Coast Region	0.253	0.095	0.048	4,576,371	10.7%	1,158,415	5.5%	84.6%	33.2%	0.0%	0.0%	0.0%

Notes: The last row shows the averages and totals for the West Coast region. Under the section on ‘population estimates’ the percentage reported in the last row of ‘share of the population’ refers to the national share, while all the other elements in this column refer to the within-region shares (as suggested by the column heading). The same goes for ‘share of the poor’. The percentages in the last row of the ‘targeting’ section show the percentage of the poor in the region reached in each simulation.

5.2.2. East Coast region

The East Coast region is made up of the Eastern Cape and KwaZulu-Natal. Both these provinces include large areas of land that were formerly part of the homelands Transkei, Ciskei and KwaZulu, and hence the region is characterised as having many rural African inhabitants and high poverty rates (see Table 17 in the appendix). The Eastern Cape province is home to about 14% of South Africa's population. Measured by its total current income, the Eastern Cape is the fourth richest province in South Africa after Gauteng. However, in *per capita* income terms, the province only ranks eighth, with only the Limpopo province being worse off. About 88% of the population is classified as African, while Coloured and White people make up 8% and 4% of the population respectively. There are virtually no Asian people in this province. The estimated 1.51 million households (6.44 million people) are grouped into 25 household groups. The large number of African households allows for a rich disaggregation that separates out households in former homelands from the rest. Coloured/Asian and White households are fairly aggregated.

Approximately 20% of South Africa's population live in KwaZulu-Natal, South Africa's largest province. Measured by its total current income, KwaZulu-Natal is the third richest province in South Africa after Gauteng and the Western Cape. In *per capita* income terms the province ranks fourth. About 83% of the population are African. The province also has a fairly large number of Asian people, who make up 9% of the population. Whites make up 6%, while Coloured people only make up 2% of the population. The 2.06 million households (8.99 million people) are grouped into 32 household groups with separate subgroups for all four racial groups. As with the Eastern Cape the large number of African households allows for a distinction between households living in former homelands. Also, given the large number of Asian households in the province a total of five Asian groups were also formed.

The average per capita income in the Eastern Cape was only R6,875 per annum, less than double the poverty line of R3,864. The per capita income is slightly higher in KwaZulu-Natal, where it stands at about R9,579 per annum. The region as a whole has a poverty rate of 62%, which is only marginally lower than the poverty rate of the Border region (see Table 14). About 45% of South Africa's poor live in this highly impoverished region. As a result it is not strange to see that a large proportion of households from this region are included in the target groups of the various simulations (see Table 6).

Table 6: Poverty rates and targeted household groups in the East Coast region

IES code	GAMS code	Description	FGT poverty indices			Population estimates				Targeting (1 = YES)				
			P ₀	P ₁	P ₂	Population size	Share of population (within region)	Number of poor	Share of the poor (within region)	R40/capita	R60/capita	R80/capita	R100/capita	R120/capita
201	HEC1	EC African, Agricultural	0.642	0.348	0.230	227,094	1.5%	145,805	1.5%	1	1	0	0	0
202	HEC2	EC African, Homeland, Female, None	0.937	0.577	0.390	689,921	4.5%	646,476	6.8%	1	1	1	1	1
203	HEC3	EC African, Homeland, Female, Primary	0.896	0.531	0.357	1,036,045	6.8%	927,954	9.8%	1	1	1	1	1
204	HEC4	EC African, Homeland, Female, Lower Secondary	0.811	0.466	0.304	467,897	3.1%	379,534	4.0%	1	1	1	1	1
205	HEC5	EC African, Homeland, Female, Upper Secondary and higher, Low-income (split)	0.806	0.350	0.182	135,392	0.9%	109,119	1.2%	1	1	1	1	1
206	HEC6	EC African, Homeland, Female, Upper Secondary and higher, High-income (split)	0.032	0.012	0.004	132,249	0.9%	4,184	0.0%	0	0	0	0	0
207	HEC7	EC African, Homeland, Male, None	0.892	0.530	0.354	494,602	3.3%	441,167	4.7%	1	1	1	1	1
208	HEC8	EC African, Homeland, Male, Primary	0.813	0.461	0.309	743,475	4.9%	604,394	6.4%	1	1	1	1	1
209	HEC9	EC African, Homeland, Male, Lower Secondary	0.634	0.338	0.214	310,219	2.0%	196,597	2.1%	1	1	0	0	0
210	HEC10	EC African, Homeland, Male, Upper Secondary and higher, Low-income (split)	0.509	0.202	0.107	93,872	0.6%	47,739	0.5%	1	0	0	0	0
211	HEC11	EC African, Homeland, Male, Upper Secondary and higher, High-income (split)	0.000	0.000	0.000	123,849	0.8%	0	0.0%	0	0	0	0	0
212	HEC12	EC African, Non-Homeland, Female, None	0.813	0.422	0.270	79,924	0.5%	64,943	0.7%	1	1	1	1	1
213	HEC13	EC African, Non-Homeland, Female, Primary	0.750	0.386	0.242	162,035	1.1%	121,498	1.3%	1	1	1	0	0
214	HEC14	EC African, Non-Homeland, Female, Lower Secondary	0.634	0.318	0.193	116,083	0.8%	73,585	0.8%	1	1	0	0	0
215	HEC15	EC African, Non-Homeland, Female, Upper Secondary and higher	0.129	0.048	0.021	69,741	0.5%	9,024	0.1%	0	0	0	0	0
216	HEC16	EC African, Non-Homeland, Male, None	0.726	0.361	0.207	90,707	0.6%	65,854	0.7%	1	1	1	0	0
217	HEC17	EC African, Non-Homeland, Male, Primary	0.626	0.286	0.164	273,248	1.8%	171,138	1.8%	1	1	0	0	0
218	HEC18	EC African, Non-Homeland, Male, Lower Secondary	0.333	0.164	0.104	169,795	1.1%	56,580	0.6%	1	0	0	0	0

Table 6 continued...

219	HEC19	EC African, Non-Homeland, Male, Upper Secondary and higher	0.095	0.031	0.017	111,461	0.7%	10,591	0.1%	0	0	0	0	0
220	HEC20	EC Asian & Coloured, Primary and lower	0.605	0.241	0.123	238,879	1.6%	144,463	1.5%	1	1	0	0	0
221	HEC21	EC Asian & Coloured, Lower Secondary	0.373	0.129	0.063	150,155	1.0%	56,024	0.6%	1	0	0	0	0
222	HEC22	EC Asian & Coloured, Upper Secondary and higher	0.067	0.032	0.016	63,029	0.4%	4,237	0.0%	0	0	0	0	0
223	HEC23	EC White, Lower Secondary and lower	0.000	0.000	0.000	60,020	0.4%	0	0.0%	0	0	0	0	0
224	HEC24	EC White, Upper Secondary	0.000	0.000	0.000	109,754	0.7%	0	0.0%	0	0	0	0	0
225	HEC25	EC White, Tertiary	0.000	0.000	0.000	73,388	0.5%	0	0.0%	0	0	0	0	0
501	HKZ1	KZ African, Agricultural, Homeland	0.753	0.456	0.306	168,128	1.1%	126,530	1.3%	1	1	1	0	0
502	HKZ2	KZ African, Agricultural, Non-Homeland, Low-income (split)	0.831	0.474	0.330	65,696	0.4%	54,603	0.6%	1	1	1	1	1
503	HKZ3	KZ African, Agricultural, Non-Homeland, High-income (split)	0.663	0.288	0.155	180,466	1.2%	119,608	1.3%	1	1	0	0	0
504	HKZ4	KZ African, Homeland, Female, None	0.976	0.594	0.415	628,432	4.1%	613,239	6.5%	1	1	1	1	1
505	HKZ5	KZ African, Homeland, Female, Primary	0.883	0.519	0.339	459,103	3.0%	405,413	4.3%	1	1	1	1	1
506	HKZ6	KZ African, Homeland, Female, Lower Secondary	0.794	0.427	0.261	167,339	1.1%	132,809	1.4%	1	1	1	1	1
507	HKZ7	KZ African, Homeland, Female, Upper Secondary and higher	0.305	0.149	0.095	104,797	0.7%	31,950	0.3%	1	0	0	0	0
508	HKZ8	KZ African, Homeland, Male, None	0.850	0.482	0.312	386,446	2.5%	328,314	3.5%	1	1	1	1	1
509	HKZ9	KZ African, Homeland, Male, Primary	0.768	0.383	0.240	439,739	2.9%	337,523	3.6%	1	1	1	1	0
510	HKZ10	KZ African, Homeland, Male, Lower Secondary	0.658	0.314	0.180	161,951	1.1%	106,527	1.1%	1	1	0	0	0
511	HKZ11	KZ African, Homeland, Male, Upper Secondary and higher	0.282	0.168	0.117	194,645	1.3%	54,929	0.6%	1	0	0	0	0
512	HKZ12	KZ African, Non-Homeland, Female, None	0.782	0.426	0.265	634,490	4.2%	496,483	5.3%	1	1	1	1	1
513	HKZ13	KZ African, Non-Homeland, Female, Primary	0.751	0.385	0.242	989,303	6.5%	743,389	7.9%	1	1	1	0	0
514	HKZ14	KZ African, Non-Homeland, Female, Lower Secondary	0.570	0.251	0.140	467,574	3.1%	266,402	2.8%	1	1	0	0	0
515	HKZ15	KZ African, Non-Homeland, Female, Upper Secondary and higher, Low-income (split)	0.613	0.284	0.169	132,226	0.9%	81,022	0.9%	1	1	0	0	0
516	HKZ16	KZ African, Non-Homeland, Female, Upper Secondary and higher, High-income (split)	0.176	0.033	0.008	225,959	1.5%	39,859	0.4%	0	0	0	0	0
517	HKZ17	KZ African, Non-Homeland, Male, None	0.767	0.433	0.282	522,187	3.4%	400,360	4.2%	1	1	1	1	0

Table 6 continued...

518	HKZ18	KZ African, Non-Homeland, Male, Primary	0.582	0.267	0.158	792,897	5.2%	461,760	4.9%	1	1	0	0	0
519	HKZ19	KZ African, Non-Homeland, Male, Lower Secondary, Low-income (split)	0.759	0.337	0.194	222,031	1.5%	168,566	1.8%	1	1	1	0	0
520	HKZ20	KZ African, Non-Homeland, Male, Lower Secondary, High-income (split)	0.143	0.020	0.004	317,473	2.1%	45,374	0.5%	0	0	0	0	0
521	HKZ21	KZ African, Non-Homeland, Male, Upper Secondary and higher, Low-income (split)	0.498	0.205	0.112	177,990	1.2%	88,651	0.9%	1	0	0	0	0
522	HKZ22	KZ African, Non-Homeland, Male, Upper Secondary and higher, High-income (split)	0.030	0.004	0.001	270,037	1.8%	8,149	0.1%	0	0	0	0	0
523	HKZ23	KZ Asian, Female, Lower Secondary and lower	0.103	0.027	0.008	155,761	1.0%	16,087	0.2%	0	0	0	0	0
524	HKZ24	KZ Asian, Male, Lower Secondary and lower, Low-income (split)	0.180	0.046	0.015	128,667	0.8%	23,177	0.2%	0	0	0	0	0
525	HKZ25	KZ Asian, Male, Lower Secondary and lower, High-income (split)	0.000	0.000	0.000	168,966	1.1%	0	0.0%	0	0	0	0	0
526	HKZ26	KZ Asian, Male, Upper Secondary and higher, Low-income (split)	0.023	0.012	0.007	167,493	1.1%	3,810	0.0%	0	0	0	0	0
527	HKZ27	KZ Asian, Male, Upper Secondary and higher, High-income (split)	0.000	0.000	0.000	169,066	1.1%	0	0.0%	0	0	0	0	0
528	HKZ28	KZ Coloured	0.082	0.036	0.016	69,778	0.5%	5,698	0.1%	0	0	0	0	0
529	HKZ29	KZ White, Lower Secondary and lower	0.000	0.000	0.000	57,481	0.4%	0	0.0%	0	0	0	0	0
530	HKZ30	KZ White, Upper Secondary, Low-income (split)	0.023	0.002	0.000	97,179	0.6%	2,202	0.0%	0	0	0	0	0
531	HKZ31	KZ White, Upper Secondary, High-income (split)	0.000	0.000	0.000	137,896	0.9%	0	0.0%	0	0	0	0	0
532	HKZ32	KZ White, Tertiary	0.000	0.000	0.000	106,089	0.7%	0	0.0%	0	0	0	0	0
-	-	East Coast Region	0.622	0.333	0.048	15,190,119	35.6%	9,443,339	45.2%	98.2%	94.6%	75.9%	62.9%	55.1%

Notes: The last row shows the averages and totals for the West Coast region. Under the section on ‘population estimates’ the percentage reported in the last row of ‘share of the population’ refers to the national share, while all the other elements in this column refer to the within-region shares (as suggested by the column heading). The same goes for ‘share of the poor’. The percentages in the last row of the ‘targeting’ section show the percentage of the poor in the region reached in each simulation.

5.2.3. Central Region

The Central region is made up of the Free State, North West and Gauteng provinces. From a poverty perspective Gauteng is unique in the region in that it has a relatively low poverty rate (see Table 13 in the appendix). The Free State is home to about 6% of South Africa's population. The Free State has the second lowest total current household income of all the provinces in South Africa. In *per capita* income terms the province ranks fifth. About 87% of the population is African, 10% are White and 3% are Coloured. There are virtually no Asian people in the province. The 698,247 households (2.75 million people) are grouped into 16 representative household groups, twelve of which are African female- and male-headed households. A single Coloured/Asian group and three White household groups complete the disaggregation.

The slightly larger North West province is home to 8.2% of South Africa's population. Measured by its total current income, the North West has the fifth highest total income of the provinces in South Africa. In *per capita* income terms, however, the province only ranks seventh. 92% of the population is classified as African, 6% as White, while Coloured and Asian households account for 2%; there are virtually no Asian households. The 794,352 households (3.58 million people) are grouped into 16 household groups, thirteen of which are male- and female-headed African households. A single Coloured/Asian household and two White household groups are also included.

Gauteng is one of South Africa's largest and most affluent provinces. It is home to about 20% of South Africa's population. Measured by its total current income, Gauteng is the richest province in South Africa. In *per capita* income terms the province also ranks first. Approximately three-quarters of the population are African, while the province also hosts a large contingent of White people (18%). Coloureds make up 4% and Asians 2%. The 3.07 million households (7.75 million people) are grouped into 24 household groups, 14 of which are African household groups. Asian and Coloured households each have two household groups, while White households have six, reflecting the fact that over 40% of White households in South Africa live in Gauteng.

The average per capita incomes in the Free State, North West and Gauteng provinces are R12,540, R10,048 and R18,542 respectively. As shown in Table 14 in the appendix the region has a relatively low overall poverty rate, but given the size of the region about 27% of the poor live here. Table 7 shows the poverty rates for each household group in the region, as well as which households were targeted under each simulation.

Table 7: Poverty rates and targeted household groups in the Central region

IES code	GAMS code	Description	FGT poverty indices			Population estimates				Targeting (1 = YES)				
			P ₀	P ₁	P ₂	Population size	Share of population (within region)	Number of poor	Share of the poor (within region)	R40/capita	R60/capita	R80/capita	R100/capita	R120/capita
401	HFS1	FS African, Agricultural	0.702	0.391	0.256	81,512	0.5%	57,206	1.0%	1	1	1	0	0
402	HFS2	FS African, Female, None	0.922	0.511	0.320	203,145	1.3%	187,286	3.3%	1	1	1	1	1
403	HFS3	FS African, Female, Primary	0.816	0.445	0.288	402,263	2.6%	328,211	5.7%	1	1	1	1	1
404	HFS4	FS African, Female, Lower Secondary	0.537	0.272	0.167	164,133	1.1%	88,209	1.5%	1	0	0	0	0
405	HFS5	FS African, Female, Upper Secondary and higher	0.323	0.143	0.078	91,454	0.6%	29,531	0.5%	1	0	0	0	0
406	HFS6	FS African, Male, None	0.761	0.356	0.207	194,928	1.2%	148,277	2.6%	1	1	1	0	0
407	HFS7	FS African, Male, Primary, Low-income (split)	0.938	0.532	0.349	277,339	1.8%	260,198	4.5%	1	1	1	1	1
408	HFS8	FS African, Male, Primary, High-income (split)	0.218	0.059	0.022	225,962	1.4%	49,206	0.9%	0	0	0	0	0
409	HFS9	FS African, Male, Lower Secondary, Low-income (split)	0.808	0.446	0.285	133,803	0.9%	108,154	1.9%	1	1	1	1	1
410	HFS10	FS African, Male, Lower Secondary, High-income (split)	0.083	0.009	0.002	107,923	0.7%	8,990	0.2%	0	0	0	0	0
411	HFS11	FS African, Male, Upper Secondary and higher, Low-income (split)	0.595	0.250	0.142	80,481	0.5%	47,895	0.8%	1	1	0	0	0
412	HFS12	FS African, Male, Upper Secondary and higher, High-income (split)	0.000	0.000	0.000	111,234	0.7%	0	0.0%	0	0	0	0	0
413	HFS13	FS Asian & Coloured	0.432	0.231	0.139	58,035	0.4%	25,075	0.4%	1	0	0	0	0
414	HFS14	FS White, Lower Secondary and lower	0.000	0.000	0.000	80,371	0.5%	0	0.0%	0	0	0	0	0
415	HFS15	FS White, Upper Secondary	0.000	0.000	0.000	125,358	0.8%	0	0.0%	0	0	0	0	0
416	HFS16	FS White, Tertiary	0.000	0.000	0.000	75,467	0.5%	0	0.0%	0	0	0	0	0

Table 7 continued...

601	HNW1	NW African, Agricultural	0.619	0.303	0.186	78,989	0.5%	48,877	0.9%	1	1	0	0	0
602	HNW2	NW African, Female, None	0.829	0.441	0.281	301,664	1.9%	250,087	4.4%	1	1	1	1	1
603	HNW3	NW African, Female, Primary	0.756	0.401	0.253	485,950	3.1%	367,216	6.4%	1	1	1	0	0
604	HNW4	NW African, Female, Lower Secondary	0.479	0.209	0.120	215,185	1.4%	102,998	1.8%	1	0	0	0	0
605	HNW5	NW African, Female, Upper Secondary and higher	0.355	0.176	0.113	144,234	0.9%	51,192	0.9%	1	0	0	0	0
606	HNW6	NW African, Male, None, Low-income (split)	0.921	0.567	0.396	173,485	1.1%	159,696	2.8%	1	1	1	1	1
607	HNW7	NW African, Male, None, High-income (split)	0.683	0.243	0.112	204,120	1.3%	139,489	2.4%	1	1	1	0	0
608	HNW8	NW African, Male, Primary, Low-income (split)	0.800	0.404	0.251	256,969	1.6%	205,450	3.6%	1	1	1	1	1
609	HNW9	NW African, Male, Primary, High-income (split)	0.204	0.045	0.013	280,067	1.8%	57,194	1.0%	0	0	0	0	0
610	HNW10	NW African, Male, Lower Secondary, Low-income (split)	0.578	0.269	0.162	174,529	1.1%	100,867	1.8%	1	1	0	0	0
611	HNW11	NW African, Male, Lower Secondary, High-income (split)	0.116	0.035	0.012	204,808	1.3%	23,741	0.4%	0	0	0	0	0
612	HNW12	NW African, Male, Upper Secondary and higher, Low-income (split)	0.297	0.121	0.062	104,330	0.7%	30,949	0.5%	1	0	0	0	0
613	HNW13	NW African, Male, Upper Secondary and higher, High-income (split)	0.000	0.000	0.000	137,381	0.9%	0	0.0%	0	0	0	0	0
614	HNW14	NW Asian & Coloured	0.299	0.166	0.106	42,466	0.3%	12,677	0.2%	1	0	0	0	0
615	HNW15	NW White, Lower Secondary and lower	0.023	0.007	0.002	60,770	0.4%	1,394	0.0%	0	0	0	0	0
616	HNW16	NW White, Upper Secondary and higher	0.000	0.000	0.000	82,877	0.5%	0	0.0%	0	0	0	0	0
701	HGT1	GT African, Agricultural	0.361	0.162	0.091	133,848	0.9%	48,288	0.8%	1	0	0	0	0
702	HGT2	GT African, Non-Homeland, Female, None	0.655	0.312	0.177	436,043	2.8%	285,550	5.0%	1	1	0	0	0
703	HGT3	GT African, Non-Homeland, Female, Primary	0.560	0.279	0.170	973,378	6.2%	545,378	9.5%	1	0	0	0	0
704	HGT4	GT African, Female, Lower Secondary	0.435	0.176	0.097	966,890	6.2%	420,162	7.3%	1	0	0	0	0
705	HGT5	GT African, Non-Homeland, Female, Upper Secondary, Low-income (split)	0.408	0.186	0.111	186,254	1.2%	75,967	1.3%	1	0	0	0	0
706	HGT6	GT African, Non-Homeland, Female, Upper Secondary, High-income (split)	0.065	0.006	0.001	280,796	1.8%	18,217	0.3%	0	0	0	0	0
707	HGT7	GT African, Non-Homeland, Female, Tertiary	0.078	0.025	0.013	72,086	0.5%	5,640	0.1%	0	0	0	0	0
708	HGT8	GT African, Non-Homeland, Male, None	0.501	0.216	0.124	451,415	2.9%	225,961	3.9%	1	0	0	0	0
709	HGT9	GT African, Non-Homeland, Male, Primary	0.374	0.145	0.076	1,458,923	9.3%	545,166	9.5%	1	0	0	0	0

Table 7 continued...

710	HGT10	GT African, Non-Homeland, Male, Lower Secondary	0.225	0.091	0.050	1,648,472	10.6%	371,347	6.5%	0	0	0	0	0
711	HGT11	GT African, Non-Homeland, Male, Upper Secondary	0.127	0.037	0.016	1,303,884	8.4%	165,967	2.9%	0	0	0	0	0
712	HGT12	GT African, Non-Homeland, Male, unknown	0.267	0.057	0.022	126,022	0.8%	33,646	0.6%	1	0	0	0	0
713	HGT13	GT African, Non-Homeland, Male, Tertiary, Low-income (split)	0.000	0.000	0.000	86,881	0.6%	0	0.0%	0	0	0	0	0
714	HGT14	GT African, Non-Homeland, Male, Tertiary, High-income (split)	0.000	0.000	0.000	103,934	0.7%	0	0.0%	0	0	0	0	0
715	HGT15	GT Coloured, Lower Secondary and lower	0.268	0.092	0.040	262,431	1.7%	70,336	1.2%	1	0	0	0	0
716	HGT16	GT Coloured, Upper Secondary and higher	0.046	0.010	0.002	167,498	1.1%	7,761	0.1%	0	0	0	0	0
717	HGT17	GT Asian, Lower Secondary and lower	0.153	0.101	0.080	54,920	0.4%	8,383	0.1%	0	0	0	0	0
718	HGT18	GT Asian, Upper Secondary and higher	0.020	0.004	0.001	105,125	0.7%	2,072	0.0%	0	0	0	0	0
719	HGT19	GT White, Lower Secondary and lower, Low-income (split)	0.094	0.030	0.009	127,827	0.8%	12,044	0.2%	0	0	0	0	0
720	HGT20	GT White, Lower Secondary and lower, High-income (split)	0.000	0.000	0.000	203,601	1.3%	0	0.0%	0	0	0	0	0
721	HGT21	GT White, Upper Secondary, Low-income (split)	0.000	0.000	0.000	298,420	1.9%	0	0.0%	0	0	0	0	0
722	HGT22	GT White, Upper Secondary, High-income (split)	0.000	0.000	0.000	344,746	2.2%	0	0.0%	0	0	0	0	0
723	HGT23	GT White, Tertiary, Low-income (split)	0.000	0.000	0.000	232,440	1.5%	0	0.0%	0	0	0	0	0
724	HGT24	GT White, Tertiary, High-income (split)	0.000	0.000	0.000	226,991	1.5%	0	0.0%	0	0	0	0	0
-	-	Central Region	0.367	0.169	0.100	15,614,057	36.6%	5,731,949	27.5%	87.2%	47.0%	38.6%	26.2%	26.2%

Notes: The last row shows the averages and totals for the West Coast region. Under the section on ‘population estimates’ the percentage reported in the last row of ‘share of the population’ refers to the national share, while all the other elements in this column refer to the within-region shares (as suggested by the column heading). The same goes for ‘share of the poor’. The percentages in the last row of the ‘targeting’ section show the percentage of the poor in the region reached in each simulation.

5.2.4. Border Region

The Border region, which is made up of the Mpumalanga and Limpopo provinces, is the most impoverished region in South Africa with a poverty rate of 63% (Table 14). However, given its small population only about 22% of the poor live in the region. Most of the poverty is driven by the very high poverty rate in Limpopo, which together with the Eastern Cape are the two most impoverished provinces in South Africa (see Table 13). Mpumalanga is home to 7.0% of South Africa's population. Measured by its total current income, Mpumalanga has the third lowest total income of the provinces in South Africa. In *per capita* income terms, however, the province ranks fourth lowest. About 91% of the population is African, while 7% are White. Coloured and Asian households together make up 2% of the population.

Limpopo is somewhat larger with 11.8% of the South African population. Measured by its total current income, Limpopo is ranked sixth of all the provinces in South Africa in terms of total income. In *per capita* income terms, however, the province is the poorest. About 97% of the population is African, while 2% are White. The Coloured and Asian population jointly accounts for less than 1% of the population. Mpumalanga with its 648,410 households (3.00 million people) and Limpopo with 1.03 million households (5.56 million people) have similar household groupings. Both have 12 African household groups, and a single household group each for Coloured/Asian and White households, giving a total of 14 households. Both the provinces in the Border region have very low per capita incomes (R8,868 in Mpumalanga and R6,178 in Limpopo). Table 8 shows the poverty rates for each household group in the region, as well as which households were targeted under each simulation.

Table 8: Poverty rates and targeted household groups in the Border region

IES code	GAMS code	Description	FGT poverty indices			Population estimates				Targeting (1 = YES)				
			P ₀	P ₁	P ₂	Population size	Share of population (within region)	Number of poor	Share of the poor (within region)	R40/capita	R60/capita	R80/capita	R100/capita	R120/capita
801	HMP1	MP African, Agricultural	0.503	0.226	0.137	80,462	1.1%	40,489	0.9%	1	0	0	0	0
802	HMP2	MP African, Female, None	0.762	0.390	0.235	462,715	6.4%	352,806	7.8%	1	1	1	0	0
803	HMP3	MP African, Female, Primary	0.675	0.300	0.168	361,656	5.0%	244,249	5.4%	1	1	0	0	0
804	HMP4	MP African, Female, Lower Secondary	0.601	0.228	0.112	157,442	2.2%	94,676	2.1%	1	1	0	0	0
805	HMP5	MP African, Female, Upper Secondary and higher	0.370	0.161	0.087	113,385	1.6%	41,914	0.9%	1	0	0	0	0
806	HMP6	MP African, Male, None	0.689	0.350	0.213	400,516	5.5%	276,019	6.1%	1	1	1	0	0
807	HMP7	MP African, Male, Primary, Low-income (split)	0.853	0.446	0.273	213,074	2.9%	181,857	4.0%	1	1	1	1	1
808	HMP8	MP African, Male, Primary, High-income (split)	0.213	0.048	0.014	263,077	3.6%	55,978	1.2%	0	0	0	0	0
809	HMP9	MP African, Male, Lower Secondary, Low-income (split)	0.524	0.176	0.083	76,003	1.0%	39,836	0.9%	1	0	0	0	0
810	HMP10	MP African, Male, Lower Secondary, High-income (split)	0.068	0.017	0.005	127,162	1.8%	8,599	0.2%	0	0	0	0	0
811	HMP11	MP African, Male, Upper Secondary and higher, Low-income (split)	0.378	0.140	0.076	92,766	1.3%	35,081	0.8%	1	0	0	0	0
812	HMP12	MP African, Male, Upper Secondary and higher, High-income (split)	0.000	0.000	0.000	108,542	1.5%	0	0.0%	0	0	0	0	0
813	HMP13	MP Asian & Coloured	0.101	0.016	0.003	33,517	0.5%	3,385	0.1%	0	0	0	0	0
814	HMP14	MP White	0.014	0.008	0.005	149,135	2.1%	2,141	0.0%	0	0	0	0	0

Table 8 continued...

901	HLP1	LP African, Agricultural	0.554	0.244	0.140	131,554	1.8%	72,887	1.6%	1	0	0	0	0
902	HLP2	LP African, Female, Non & pre-Primary	0.819	0.448	0.284	1,123,565	15.5%	920,289	20.2%	1	1	1	1	1
903	HLP3	LP African, Female, Primary	0.840	0.482	0.314	682,495	9.4%	573,404	12.6%	1	1	1	1	1
904	HLP4	LP African, Female, Lower Secondary	0.770	0.390	0.246	334,972	4.6%	257,951	5.7%	1	1	1	1	0
905	HLP5	LP African, Female, Upper Secondary and higher, Low-income (split)	0.807	0.401	0.241	146,871	2.0%	118,577	2.6%	1	1	1	1	1
906	HLP6	LP African, Female, Upper Secondary and higher, High-income (split)	0.173	0.041	0.012	131,991	1.8%	22,869	0.5%	0	0	0	0	0
907	HLP7	LP African, Male, None	0.777	0.354	0.203	522,480	7.2%	406,189	8.9%	1	1	1	1	0
908	HLP8	LP African, Male, Primary, Low-income (split)	0.923	0.583	0.403	341,564	4.7%	315,253	6.9%	1	1	1	1	1
909	HLP9	LP African, Male, Primary, High-income (split)	0.442	0.143	0.062	398,309	5.5%	175,916	3.9%	1	0	0	0	0
910	HLP10	LP African, Male, Lower Secondary	0.543	0.240	0.139	362,039	5.0%	196,418	4.3%	1	0	0	0	0
911	HLP11	LP African, Male, Upper Secondary and higher, Low-income (split)	0.650	0.337	0.203	159,899	2.2%	103,870	2.3%	1	1	0	0	0
912	HLP12	LP African, Male, Upper Secondary and higher, High-income (split)	0.000	0.000	0.000	205,745	2.8%	0	0.0%	0	0	0	0	0
913	HLP13	LP Asian & Coloured	0.305	0.160	0.098	15,069	0.2%	4,596	0.1%	1	0	0	0	0
914	HLP14	LP White	0.000	0.000	0.000	69,047	1.0%	0	0.0%	0	0	0	0	0
-	-	Border Region	0.626	0.314	0.192	7,265,052	17.0%	4,545,248	21.8%	98.0%	84.6%	74.9%	61.0%	46.4%

Notes: The last row shows the averages and totals for the West Coast region. Under the section on 'population estimates' the percentage reported in the last row of 'share of the population' refers to the national share, while all the other elements in this column refer to the within-region shares (as suggested by the column heading). The same goes for 'share of the poor'. The percentages in the last row of the 'targeting' section show the percentage of the poor in the region reached in each simulation.

5.3. Closures

Model closures are selected with the objective of providing a realistic representation of the South African economy. In a policy experiment such as this one where a large expenditure is incurred by the government, the government closure rules are important as they capture the different financing options to be considered by policy makers. Mathematically speaking, closure rules ensure that the number of variables and equations in the model are consistent, a necessary condition for the model to solve. In economic terms closure rules define fundamental differences in perceptions of how economic systems operate.

5.3.1. *Government closure*

Two government closures are considered. In the base-scenario the *government account* is closed by variations in the level of government borrowing or savings – that is the size of the budget deficit or surplus. This implies that the increase in transfers from government to targeted households is financed through an increase in government borrowings (deficit financing). All tax rates are assumed to remain constant under the deficit financing closure.

Alternatively the government can raise revenue via an increase in the direct income tax rate of households. Various other tax rate instruments could also have been considered, but given that the funding is required for transfers to households it seems realistic that government would recover these funds from household income taxes. Essentially the average household tax rate under the tax replacement scenario is endogenised and the model solves for that tax rate that will balance the government budget.

The model simulations also allow for the specification of an administration cost component. As mentioned previously *sim01* to *sim05* simulates transfers ranging from R40 to R120 for each member of a targeted household with zero administration cost, while *sim06* to *sim10* repeat the same, only now assuming an administration cost component equal to 25% of the total transfer value of R15 billion (R3.75 billion). This administration cost component is added to the government expenditure on goods and services and therefore it makes sense to fix the value of government expenditure in the closure.

5.3.2. *Factor market closures*

There are various factors of production in the model, including land, capital and different types of labour. The labour accounts are grouped into three sub-groups labelled ‘skilled and high skilled’, ‘semi-skilled’ and ‘unskilled’. Land is always fully employed and activity-specific, i.e. it cannot be moved from one activity to the other. For the capital market closure we distinguish between the long- and short run. In the long run capital is fully employed and

fully mobile across sectors. In a short-run closure capital is activity-specific. Skilled labour is always fully employed and fully mobile across sectors. However, for semi-skilled and unskilled labour certain of the closures explore the situation where such factors are unemployed.

Table 23 lists all the accounts in the model SAM, including the factor groups. The allocation of labour accounts to the three broad labour categories is listed in Table 9. In all the closures ‘skilled and high-skilled’ workers are assumed fully employed. ‘Unskilled’ workers, on the other hand, are typically modelled as unemployed given South Africa’s high unemployment rate among poorly educated low-skilled workers (see Borat and Leibbrandt, 1996). The more difficult group is the ‘semi-skilled’ one. By construction this group contains workers that are unskilled (such as White unskilled workers), semi-skilled (mostly African semi-skilled workers) or unspecified (such as aggregated Coloured and Asian workers), and hence some uncertainty exists as to which closure best applies to this group. Consequently we regard this as a ‘grey area’, which is why different closure alternatives are explored (see Table 10).

Table 9: Labour group classifications

Skilled & High-skilled – always fully employed		Semi-skilled – ‘grey area’, compare full employment and unemployment closures		Unskilled – always unemployed	
fwcafskil	WC Skilled African labour	fwcafuns	WC Semi and Un skilled African labour	fwccounsk	WC Unskilled Coloured labour
fwccoskil	WC Skilled Coloured and Asian labour	fwcwhunsk	WC Unskilled White labour	fwccofm	WC Farm Coloured and Asian labour
fwcwhskil	WC Skilled White labour	fecwhunsk	EC Unskilled White labour	fecafunsk	EC Unskilled African labour
fecafskil	EC Skilled African labour	fnccolab	NC Coloured and Asian labour	fecaffm	EC Farm African labour
feccoasskil	EC Coloured and Asian skilled labour	ffscolab	FS Coloured and Asian labour	feccounsk	EC Coloured and Asian unskilled
fecwhskil	EC Skilled White labour	ffswhunsk	FS Unskilled White labour	fncaflab	NC African labour
fnwhlab	NC White labour	fkznafsemi	KZN Semi skilled African labour	ffsafunsk	FS Unskilled African labour
ffsafskil	FS Skilled African labour	fkzncolab	KZN Coloured labour	fkznafunsk	KZN Unskilled African labour
ffswskil	FS Skilled White labour	fkznwhunsk	KZN Unskilled White labour	fkznaffm	KZN Farm African labour
fkznafskil	KZN Skilled African labour	fnwafsemi	NW Semi skilled African labour	fkznasunsk	KZN Unskilled Asian labour
fkznasskil	KZN Skilled Asian labour	fnwcolab	NW Coloured labour	fnwafunsk	NW Unskilled African labour
fkznwhskil	KZN Skilled White labour	fgtafsemi	GT Semi skilled African labour	fgtafunsk	GT Unskilled African labour
fnwafskil	NW Skilled African labour	fgtcolab	GT Coloured labour	fmpafunsk	MP Unskilled African labour
fnwhlab	NW White labour	fgtaslab	GT Asian labour	flpafunsk	LP Unskilled African labour
fgtafskil	GT Skilled African labour	fgtwhunsk	GT Unskilled White labour		
fgtwhskil	GT Skilled White labour	fmpafsemi	MP Semi skilled African labour		
fmpafskil	MP Skilled African labour	fmpcolab	MP Coloured and Asian labour		
fmpwhskil	MP Skilled White labour	fmpwhunsk	MP Unskilled White labour		
flpafskil	LP Skilled African labour	flpafsemi	LP Semi skilled African labour		
flpwhlab	LP White labour	flpcolab	LP Coloured and Asian labour		

5.3.3. Other closures

The *foreign exchange market* is assumed to clear via a flexible exchange rate and therefore the external balance (or current account balance) remains fixed. Since South Africa is a small country it is a price taker on international markets, i.e. all prices of imported and exported goods are fixed in foreign currency units.

The *capital account* records all savings and investment related transactions. Under the deficit financing option a savings-driven investment closure is assumed whereby the household and enterprise savings rates are fixed. As the deficit increases the total pool of savings in the economy falls, and therefore investments decline as well. Under all the tax replacement closures the capital account is closed by assuming that the share of investment expenditure in total final domestic demand remains constant. This allows for some variation in the volume of investment due to changes in the prices of investment goods and from any

change in the total value of domestic absorption. The equilibrating variables are the savings rates of all households and incorporated business enterprises. These rates are allowed to vary equiproportionately, which ensures that the savings equal investments in the economy.

All prices in a CGE model are expressed relative to the *numéraire*, a fixed price (or price index) in the model. In this study the model *numéraire* is the consumer price index (CPI), and consequently all the value results of the model are expressed in real terms. Table 10 provides a summary of the different closures considered in the model.

Table 10: Closures in the model

Closure name	Government	Capital	Semi-skilled labour	Unskilled labour
<i>deficitfin</i>	Deficit finance closure. Assume 0% administration cost for simulations 1 to 5 and 25% for simulations 6 to 10.	Fully employed and mobile (long run)	Fully employed and mobile	Fully employed and mobile
<i>hhdirtaxsr1</i>	Flexible household income tax rate closure. Assume 0% administration cost for simulations 1 to 5 and 25% for simulations 6 to 10.	Fully employed and activity-specific (short run)	Fully employed and mobile	Fully employed and mobile
<i>hhdirtaxsr2</i>	Flexible household income tax rate closure. Assume 0% administration cost for simulations 1 to 5 and 25% for simulations 6 to 10.	Fully employed and activity-specific (short run)	Fully employed and mobile	Unemployed
<i>hhdirtaxsr3</i>	Flexible household income tax rate closure. Assume 0% administration cost for simulations 1 to 5 and 25% for simulations 6 to 10.	Fully employed and activity-specific (short run)	Unemployed	Unemployed
<i>hhdirtaxlr</i>	Flexible household income tax rate closure. Assume 0% administration cost for simulations 1 to 5 and 25% for simulations 6 to 10.	Fully employed and mobile (long run)	Fully employed and mobile	Unemployed

Notes: Skilled labour is always fully employed and mobile while land is always fully employed and activity-specific. Under the deficit financing closure the model is savings-driven, while a ‘balanced’ savings-investment closure is set up for the remaining closures.

5.4. Final remarks about the model setup and simulations

As with any other attempts at modelling behaviour there are some limitations to the way in which the household transfer is simulated here. One such limitation is a general weakness of CGE models that make use of the representative household group assumption whereby each individual member of the representative household is assumed to act in exactly the same way. The way in which household groups were formed in the SAM tries to explain as much of the heterogeneity by forming many diverse household groups, but lacks an explicit income

dimension. Therefore each household group contains both ‘poor’ and ‘non-poor’ individuals (or households), and hence in theory, even though relatively poor household groups are targeted, both poor and non-poor members of a household group will receive the transfer.

Tying in with this are the notions of take-up rates and self-selection. In the modelling of the welfare transfer we assume that all members of a targeted household group receive and take up the transfer. Arguably a household group with a larger proportion of non-poor individuals, many of who may be working individuals, will have a lower take-up rate because individuals will consider the opportunity cost of waiting in a queue to receive the transfer and may therefore decide against taking up the grant (self-selection).

The targeting options are also numerous. Some may argue that it is better to target household groups with a high depth of poverty as measured by the P_1 or P_2 measures. Alternatively one could target households with a large absolute number of poor individuals, or household groups with the largest proportion of poor people within the region or within in the country as a whole. The targeting criterion in this study represents one option out of whole range of options and is particularly useful to study the impact of targeting on poverty rates among the poorest households groups, while it is also useful for comparisons between broad and narrow targeting with a fixed budget constraint.

6. Results

6.1. CGE model results

6.1.1. *The government closure and administration costs*

Section 5.3.1 described the various government closures considered. In simulations one to five (*sim01* to *sim05*) the cost of the transfer is held constant at R15 billion, while in simulations six to ten (*sim06* to *sim10*) an administration cost of R3.75 billion is added to the R15 billion transfer cost. In both these sets of simulations the cost is either financed via an increase in the government deficit (closure *deficitfin*) or via an increase in household income taxes collected by government (any of the other closures). Here we compare closure *deficitfin* and the short-run full employment closure (*hhdirtaxsr1*) (see Table 10) to evaluate the impact under different government closure assumptions. In all instances only *sim01* and *sim06* are considered. These simulations represent a broadly targeted R40 per capita per annum transfer either without (*sim01*) or with (*sim06*) an administration cost component.

The R15 billion transfer value represents an increase in transfers from government to households from R26.7 billion in the base to R41.7 billion (56.2%). In *sim06* an additional amount of R3.75 billion is incurred in respect of administration costs. This is a 2.4% increase

in government's base-level expenditure on goods and services of R156.7 billion. Under the deficit financing closure option the increased expenditure leads to an increase in the deficit from R20.3 billion (2.6% of GDP) in the base to R35.6 billion (75.2% increase to 4.5% of GDP) in *sim01* and R39.8 billion (96.3% increase to 5.0% of GDP) in *sim06*.¹⁷

Under the savings-driven investment closure adopted for the deficit financing closure the savings rates of households and enterprises are fixed, and any change in total savings by these institutions comes as a result of changes in income. Under this closure households increase savings by 0.8% and 0.9% in *sim01* and *sim06* respectively, while enterprise savings are largely unaffected (0.0% and -0.1%). However, the large drop in government savings causes overall savings in the economy to decline by 10.3% and 13.3% in *sim01* and *sim06* respectively, and hence total investment declines by these same percentages. Households' disposable income increases as a result of the increased transfer, and hence they are able to increase expenditure. In fact, real private consumption of all households increases by 2.5% and 2.6% in *sim01* and *sim06*. However, this comes at the expense of a rather substantial reduction in investments. This will directly impact on the future growth potential of the economy via its impact on capital stock, which will decline substantially. Although a static CGE model such as this does show this adverse effect directly, a dynamic model will pick up changes in capital stock over time and the impact will be seen in the productive capacity of the economy.

In the tax replacement closure (*hhdirtaxsr1*) the investment share of domestic demand is fixed. The value of domestic demand barely changes (-0.1% and 0.0% in *sim01* and *sim06*) and therefore total investment is also virtually unchanged. Since household taxes are increased in order to maintain the base-level government deficit direct tax revenue is increased by 12.5% and 16.2% in *sim01* and *sim06* respectively from a base of R119.4 billion. All the additional tax revenue is sourced from households, whose average tax rates increase by 16.5% and 21.5% in *sim01* and *sim06* respectively.¹⁸ Figure 5 shows the transfer and administration costs graphically under different financing options.

While higher taxes decrease the disposable income of households, the increased transfers have a positive effect. The end result is only small changes in overall private household consumption: it remains constant in *sim01*, but decreases by 0.7% in *sim06* due to added requirement of financing the administration costs. These are of course the aggregate economy-wide effects. Typically low-income household groups pay less tax, while they are more likely

¹⁷ The deficit-to-GDP ratios are expressed in terms of the base-level GDP of R793.6 billion. The change in nominal GDP is negligible in all the closures-simulation combinations, ranging between no change and 0.1% decline. The nominal GDP change is also negligible given almost no change in the CPI.

¹⁸ This implies that a hypothetical household that pays an *average* tax rate of 20% on income now pays 23.3% in the case of *sim01* or 24.3% in the case of *sim06*.

to receive the transfer. As a result the income distribution may change. A more detailed analysis of the intra-household effects follows (section 6.2).

Figure 5: Deficit financing and balanced budget simulations

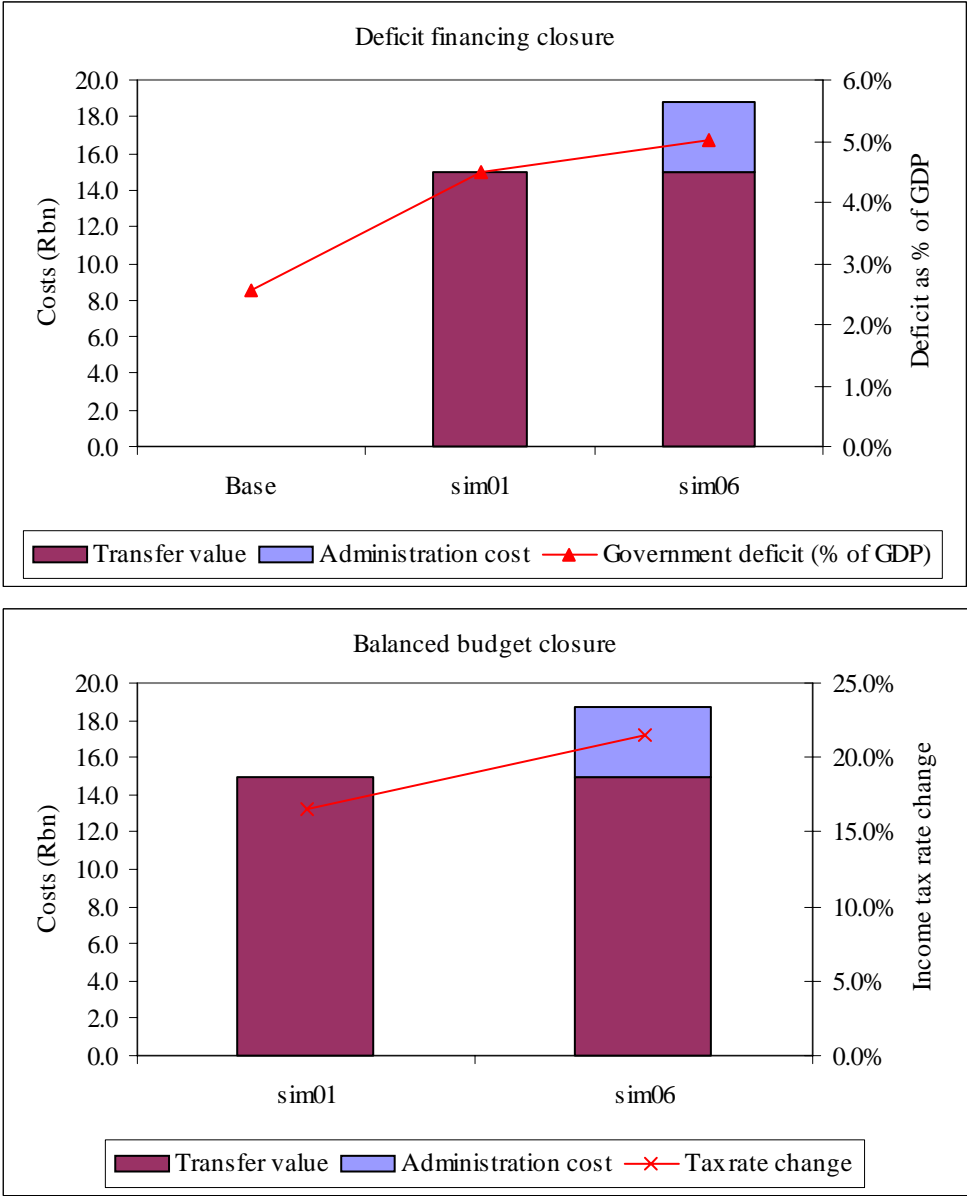

The administration cost scenario also has an employment-side effect that should be explored. Government accounts for about 26% of total expenditure (including intermediate input expenditure, consumer demand, investment and exports) on the commodity ‘other services’ (*aoserv*). This service is supplied entirely by the ‘other services’ activity. As a result of the administration cost incurred by government employment is likely to increase in this industry. In fact, under the deficit finance closure employment increases by 0.8% in *sim06* compared to only 0.3% in *sim01*. Similarly, under the tax replacement closure the employment decline in *sim06* is 0.2% compared to a much larger relative decline of 0.5% in *sim01*. Granted, these employment effects are small, but the different impacts are clear.

Some further interesting employment effects of the deficit financing closure are considered in the appendix. These effects are not central to the argument against deficit financing. More crucial is the investment impact and the effect this has on capital stock changes and the future growth potential of the economy alluded to earlier.

6.1.2. *Unemployment closures*

South Africa is infamous for its high and persistent unemployment rates. Under the standard full employment assumption wage rates adjust in order to maintain the employment level. Under the ‘unemployment’ closure a fixed wage rate is assumed, and hence the level of employment varies in order to equilibrate labour supply and demand. Thus, if labour demand for ‘unemployed’ workers increases the employment level will increase due to the assumption that excess workers are available to fill vacancies. On the other hand, if labour demand falls, some workers will become unemployed as the level of employment declines. This assumption often has important welfare implications since the unemployment closure is usually applied to low-skilled workers who typically live in low-income households, thus making this group relatively vulnerable to employment shocks. The choice of which labour categories should be included in the unemployment closure is therefore important.

The overall employment impact in the various transfer simulations is small. In fact, as shown in Figure 6 unskilled employment increases by only 0.07% in *sim01* (without administration cost) compared to a 0.06% increase in *sim06* (with administration cost). When both semi- and unskilled labour is modelled as unemployed the employment effects are slightly larger since employers can now increase demand for semi-skilled labour as well without wages the risk of rising wages.

Figure 6: Changes in employment levels under different closure assumptions

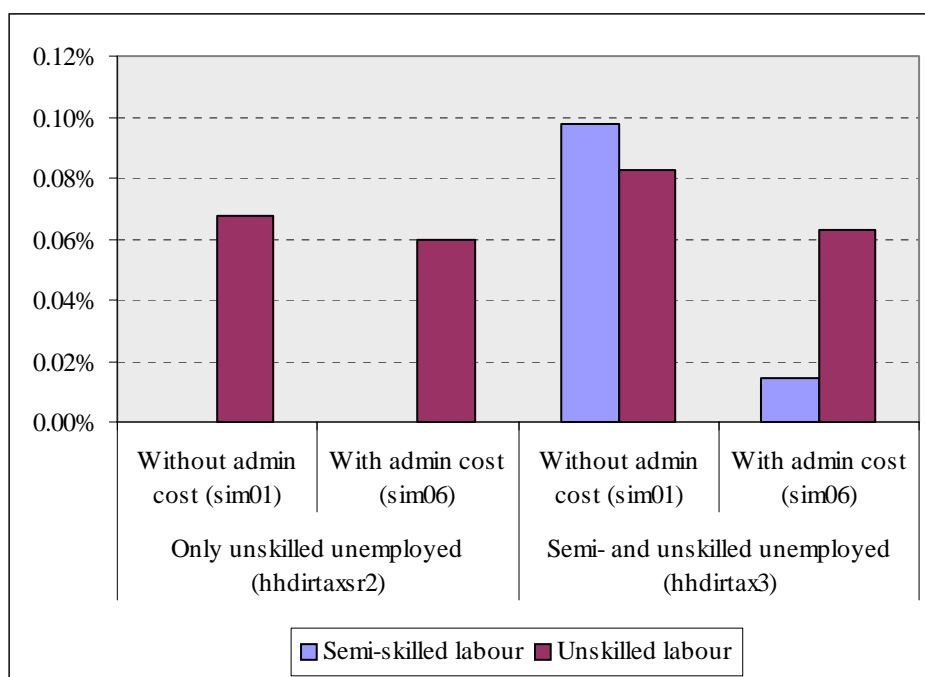
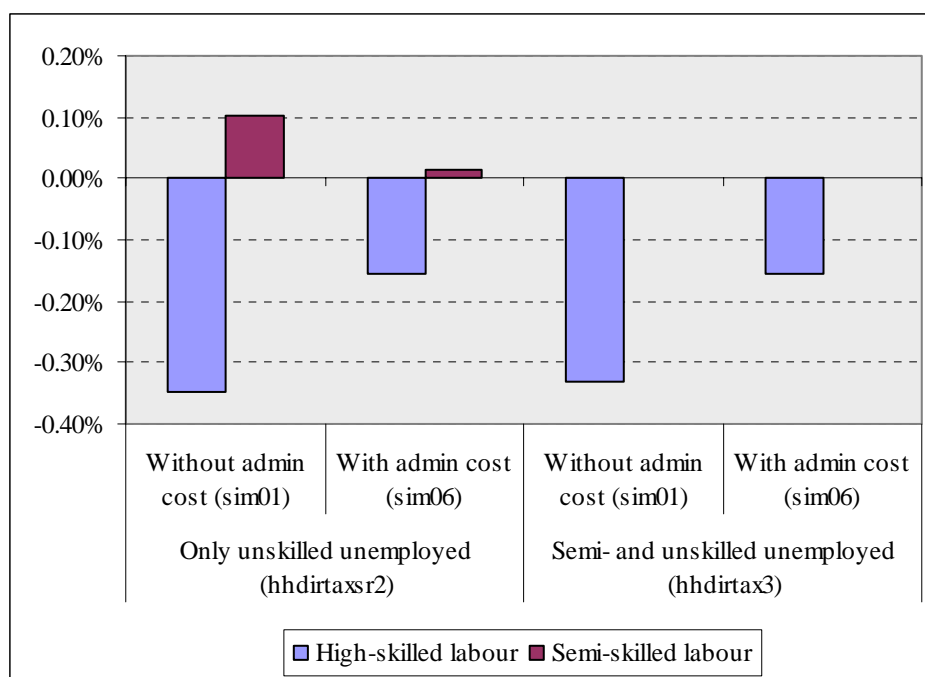

Figure 6 shows the aggregate changes in labour demand for factor groups that are unemployed. Under a full employment closure the equilibrating variable is the wage rate. Figure 7 shows the changes in wage rates under the different closures. Skilled and high-skilled workers are always fully employed, and experience a decline in average wages under both simulations, i.e. without administration cost (*sim01*) and with administration cost (*sim06*). Semi-skilled workers' average wage, however, increases as a result of an increase in demand for labour.

In general, therefore, there appears to be an overall increase in the demand for semi- and unskilled labour, and a decrease in demand for skilled and high-skilled labour, irrespective of whether a full employment or unemployment closure is modelled for semi-skilled labour. Although the percentage changes in the previous two figures are relatively small, the changing pattern of demand potentially has a welfare impact in as far as skilled labour is typically found in high-income households, while semi- and unskilled labour is typically found in middle- to lower-income household groups. Such labour demand patterns are influenced directly by consumption demand patterns. The welfare transfer in these simulations is financed by increasing direct tax rates on households. Poor households are targeted, and typically high-income households bear the brunt of the increased tax burden. The distributional effect of this is a decrease in disposable income of high-income households and *vice versa* for low-income households. Since low-income households consume commodities such as food that are more semi- and unskilled intensive in terms of production the demand for these types of factors increases as demand for the commodities increase. High-income households, on the other

hand, presumably consume more high-skilled intensive goods, and hence as their demand declines we also see a decline in the demand for these types of factors.¹⁹

Figure 7: Changes in average wages under different closure assumptions



Note: Each broad factor group is made up of SAM factor accounts as shown in Table 9. The ‘average’ change of a broad factor group is calculated as the weighted average of each individual factor account’s percentage change in the wage. The employment level (factor supply) of each factor account is used as the weight.

6.1.3. Long run and short-run closures

The model closures also make provision for a comparison between long run and short-run closures (see Table 10, closure *hhdirtaxlr*). The only difference between the long run closure and the *hhdirtaxsr2* is the assumption about the factor capital. In the short run the level of capital employed in each activity is fixed (activity-specific), while in the long run capital mobile between sectors but fully employed at a national level. While results are not affected greatly by this change, it does allow for more flexibility in that capital moves to sectors where the return to capital is higher. Table 11 suggests that, on average, capital demand increases in the producers of primary foodstuffs (agriculture and food sectors). The demand change for capital in mining is declines under the ‘with’ administration cost simulation (*sim06*). Capital demand in light manufacturing, which consists of industries such as textiles and petroleum products, increases, while there is evidence of a decline in demand for capital in the heavy manufacturing and services industries where, evidently, returns to capital are declining. This structural shift ties in with the theory proposed previously, namely that low-income

¹⁹ Further analysis is necessary to quantify some of these statements.

households, who are primarily the recipients of transfers increase demand for capital ‘unintensive’ commodities such as food and textiles, while high-income households who carry most of the increased tax burden reduce their demand for services and heavy manufacturing goods such as vehicles.

Table 11: Compositional shift in the demand for the factor capital (long run closure)

Aggregated sector	Without administration cost	With administration cost
Agriculture	1.4%	1.2%
Food	1.6%	1.3%
Mining	0.0%	-0.2%
Light manufacturing	0.5%	0.3%
Heavy manufacturing	-0.3%	-0.4%
Services	-0.2%	-0.1%

Note: Overall economy-wide demand is unchanged by construction (full employment assumption).

6.1.4. Aggregate household welfare effects

Although section 0 looks at the welfare effects of the transfer in more detail, this section briefly reviews some of the aggregate household and economy-wide welfare effects associated with the increased welfare transfer. The CGE model produces output among other things on the household expenditure change and the equivalent variation (EV), both of which can be used as an indication of the welfare impacts of a policy shock. Formally, the EV is “*the amount of money which would have to be given to the consumer [or household group] when he faces the initial price [vector], to make him as well off as he would be facing the new price [vector] with his initial income*” (for more on the definition and interpretation see Gravelle and Rees, 1992:117-119).

Welfare effects are affected by the closure rule. In Figure 8 we compare the economy-wide welfare effect of a R40, R80 and R120 per capita transfer with the administration cost option (*sim06*, *sim08* and *sim10*). We compare a full-employment deficit financing closure (*deficitfin*) with a short-run closure where we assume semi, skilled and high-skilled workers are fully employed, while unskilled workers are unemployed (*hhdirtaxsr3*). The left-hand panel shows the Slutsky approximation of the welfare effect (EV) for households. Under the deficit financing option there is a large positive effect since households benefit from the transfer without having to pay more tax. However, with the tax replacement policy in place (balanced budget) the welfare impact is negative. This is an important result as it suggests that an increase in welfare transfers will come at a net cost to society as measured (loosely) by the aggregate welfare change.

The right-hand panel of Figure 8 shows the aggregate welfare change for all domestic institutions, which includes government, households and enterprises. This measure also takes into account changes in investment. Here the net welfare effect is negative under the deficit

financing option due to the large decline in investment resulting from the large increase in the deficit. Under the balanced closure scenario, however, increased government expenditure allows for the net effect to be positive. It must be noted that these welfare effects should be used as a guideline only and are not rigorous indications of welfare changes due to aggregation and approximation issues.

Figure 8: Welfare changes using the Slutsky approximation technique

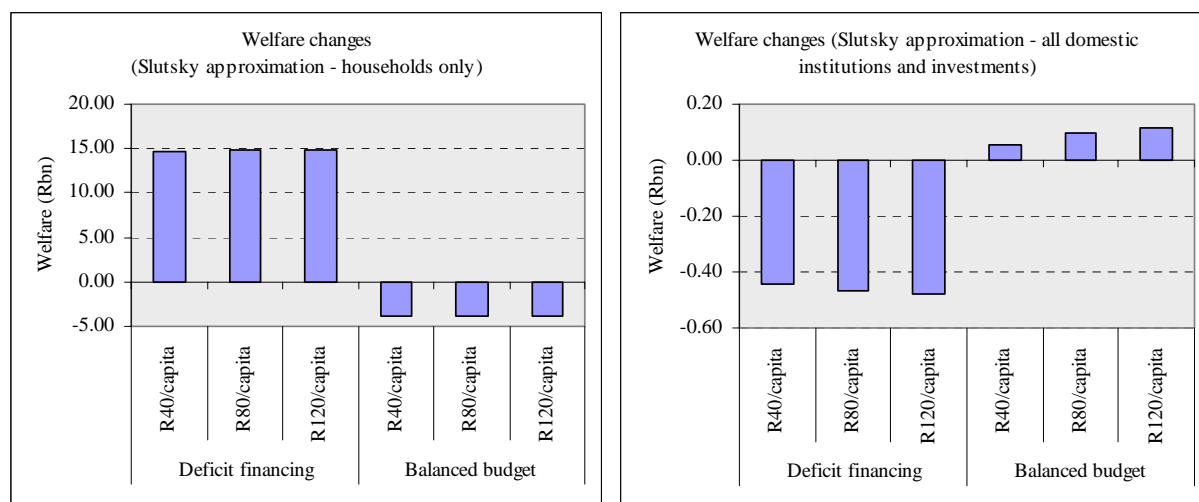

Note: The aggregate economy-wide welfare effects are very similar under all three simulations considered since the total transfer value is fixed at R15 billion. A positive change reflects a positive welfare effect and *vice versa*.

While the transfer comes at a net welfare loss for households, it is instructive to look at the welfare changes of households within provinces. Provinces such as the Eastern Cape, KwaZulu-Natal and Limpopo contain most of the poor household groups, and as a result receive a larger share of the transfer. Provinces such as Gauteng and the Western Cape, on the other hand, carry most of the increase in the tax burden and hence experience a decline in welfare. These welfare effects are shown in Figure 9. Compared to the R40 per capita transfer the welfare effects become more pronounced for the R120 transfer as fewer households in the higher income provinces receive the transfer but are still required to carry the same share of the tax burden as before. Figure 16 in the appendix (section 9.5) shows the household expenditure change by province, which follows a very similar pattern to that of the EV. The difference between these two graphs reflects the impact of price changes, and since prices move very little in these simulations the difference is not big.

Figure 9: Welfare changes by province

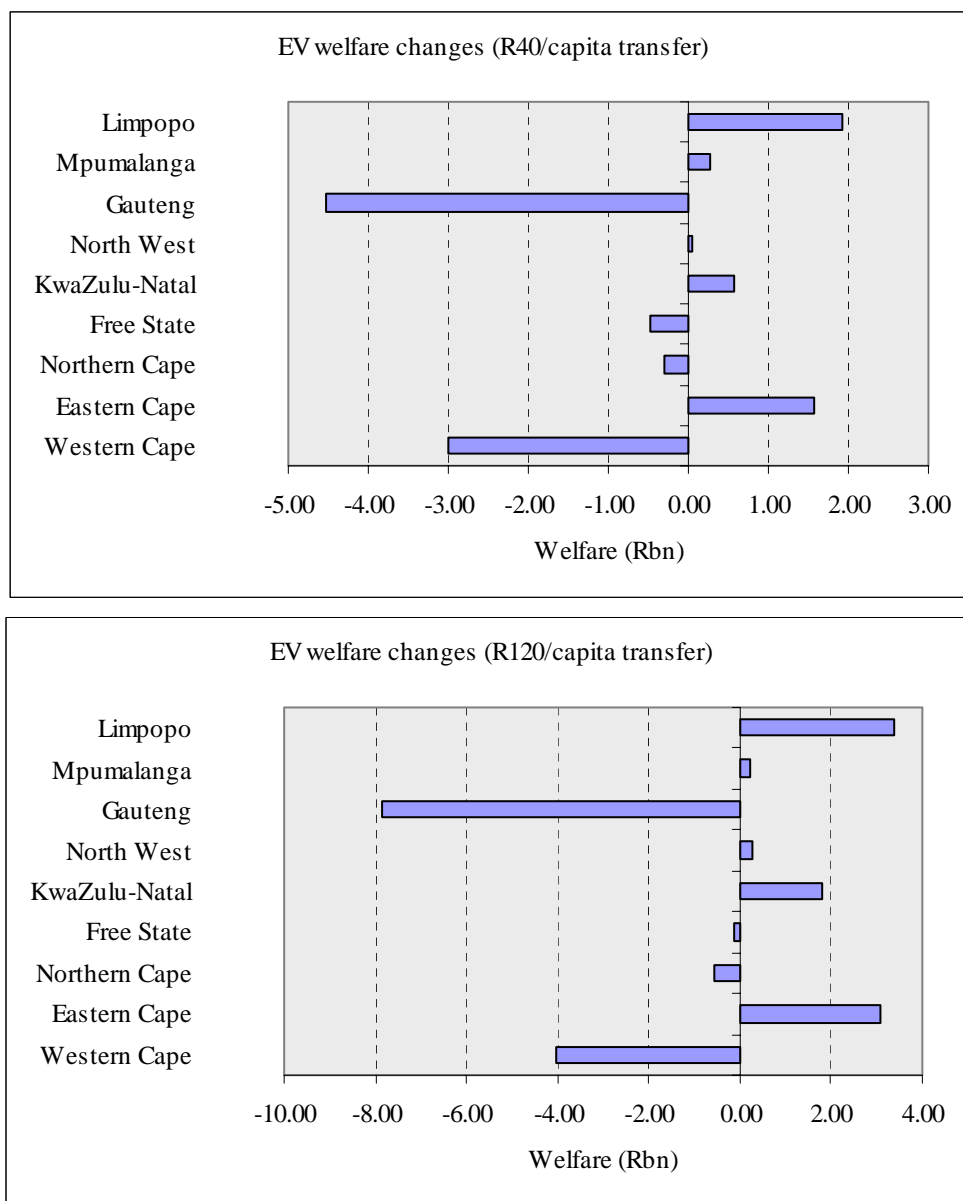
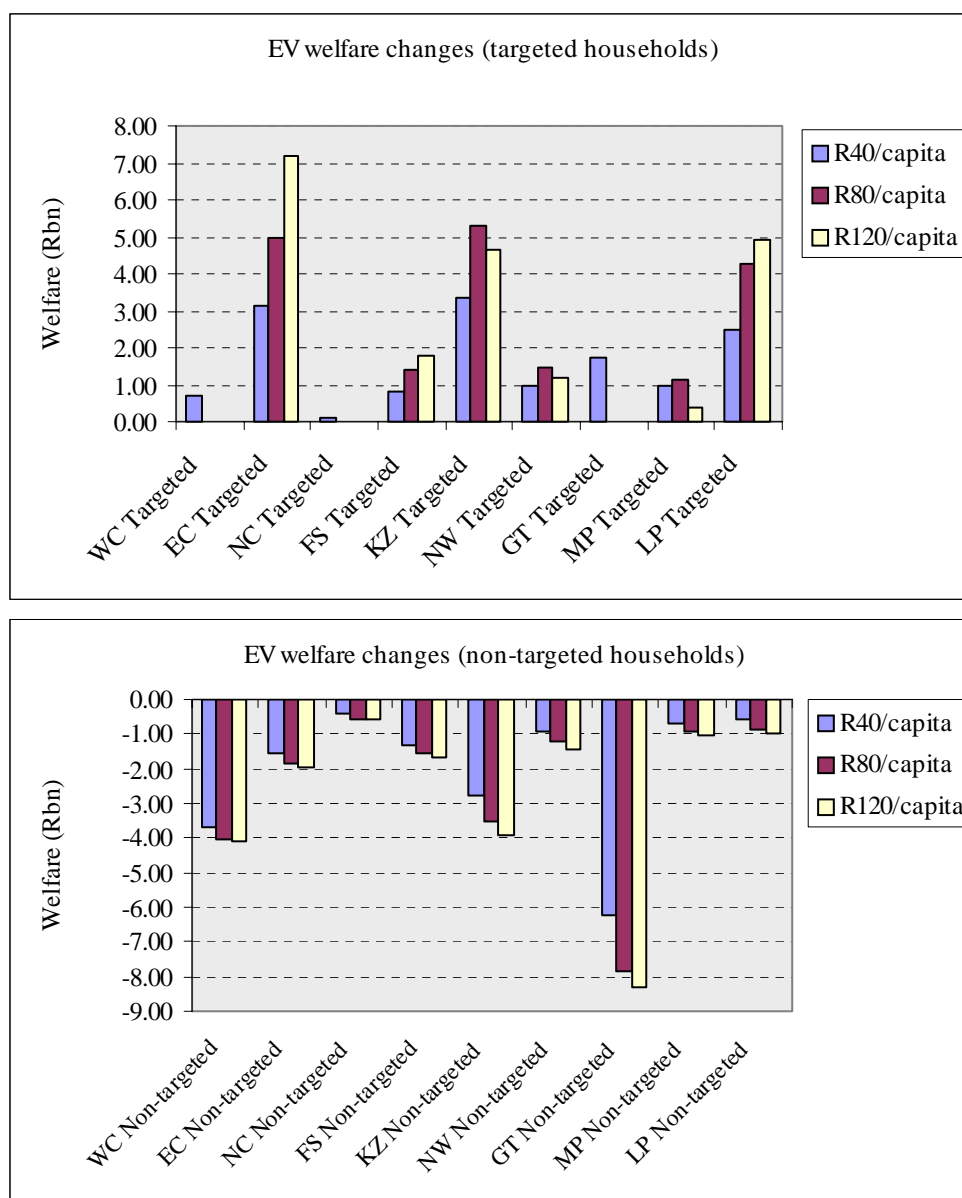

Figure 10 compares the welfare effects within each province but distinguishes between targeted and non-targeted households. In all instances targeted households experience a net welfare gain, which implies that the gain from the transfer offsets the loss associated with the increased tax. This gives weight to earlier suggestions that the recipients of the transfers typically do not pay much tax and hence are not affected by tax increases to the extent that their net gain from the transfer is negative. In some provinces where recipients are also taxpayers the gain from the transfer is fairly low. The non-targeted households, on the other hand, all experience declines in welfare due to the impact of the increased taxes.

Figure 10: Comparing welfare effects between recipient and non-recipient households



6.2. Linking the CGE results to the survey data

6.2.1. Method

Sections 3.2.3 and 3.3 presented some poverty and inequality summary statistics for the South African population. Per capita income was used as the welfare measure. These poverty and inequality estimates represent the pre-transfer (base) estimates. The method followed here takes the predicted percentage change in per capita expenditure as the welfare change measure since it takes into account the change in *disposable* income as a result of transfers received and increased taxes. These predicted changes are reported by household group in the CGE model, and given the representative household group assumption each individual member of the household group will experience the exact same change in his or her per capita

expenditure. Each individual's per capita income variable in the survey data (IES/LFS 2000) is now adjusted with this percentage change. Poverty and inequality estimates are then recalculated for the new per capita income estimates and any changes are analysed in a comparative static fashion. In particular comparisons are made across provinces (or region), race, gender of the head of the household and educational attainment of the head of the household. In all the results presented below we consider a R40, R80 and R120 per capita transfer with administration cost under the short-run tax replacement closure with semi- and unskilled unemployment (*hhdirtaxsr3*).

6.2.2. Results

The individual-level analysis using survey data suggests that the transfer simulation will have a fairly small impact on the poverty rate and the depth of poverty. Figure 11 shows a decline in the poverty headcount (P_0) from 49.0% in the base to 46.5% in the case of the R40 per capita transfer. It drops further to 45.6% for the R80 transfer, and only marginally to 45.5% in the case of the R120 transfer. Under a broadly targeted simulation many of the poor are included, and particularly those that are close to the poverty line. Even a small R40 transfer enables a relatively large group of people to escape poverty. In the R80 simulation the transfer is targeted at the very poor, many of whom are further away from the poverty line, so despite the fact that the transfer value is increased not many more people are brought out of poverty.

The figure also shows the change in the depth of poverty measure (P_1), which decline from 0.245 in the base to 0.217, 0.206 and 0.204 respectively. Clearly as the transfer value increases targets the very poor more directly the depth of poverty is reduced, i.e. more people are brought closer to the poverty line without necessarily escaping poverty.

Figure 11: National-level poverty headcount ratio and the depth of poverty

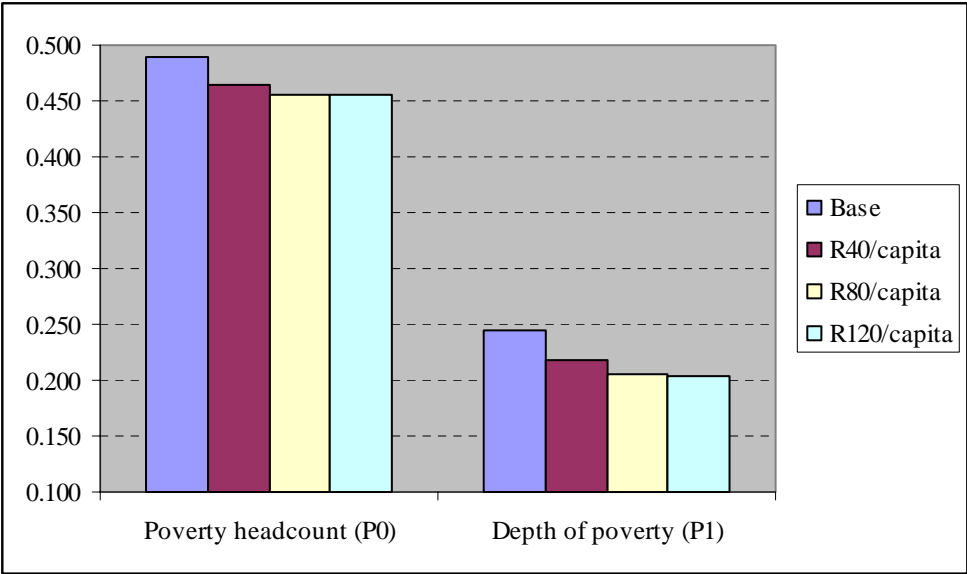

Previously the welfare impacts across provinces suggested that there are winners and losers. Figure 12 shows the regional impact on the poverty headcount ratio. The East Coast region experiences the largest decline in the poverty rate, dropping from 62.2% to 55.4%. This is not surprising given that the bulk of the transfer sum paid to people in this region, while as targeting becomes narrower funds are moved from other regions to the East Coast region. In the Border region the poverty rate also decline initially for the R40 and R80 per capita transfers, but is starts increasing again for the R120 transfer. This implies that some individuals close to the poverty line cease to receive the transfer as targeting becomes narrower and hence they drop back into poverty. Such increases in poverty rates are also seen in the West Coast and Central region. In fact, the poverty in the West Coast region actually increases from the base level of 25.3% to 26.1% in the R80 and R120 simulations. This is a tax effect with households that are actually close to the poverty line having to pay more tax but failing to qualify for the transfer. This points at the importance of ensuring an equitable distribution of the increased tax burden.²⁰

Figure 12: Regional-level poverty headcount ratio

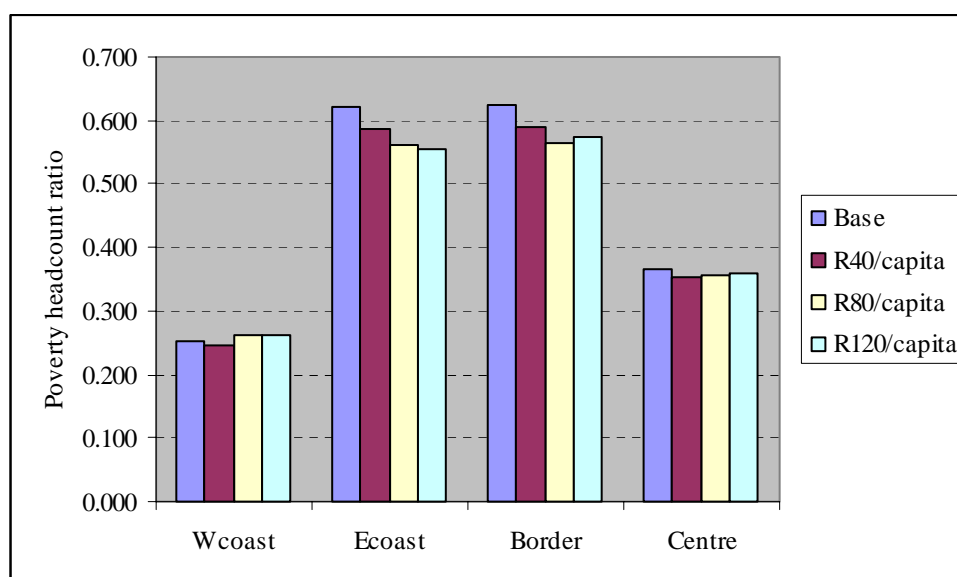

Note: See Figure 18 in the appendix (section 9.5) for a graph of the change in the depth of poverty.

Figure 13 shows the poverty impact across racial groups. Since poverty is most prevalent among African households they were also targeted in the simulations, and hence it is not surprising to see a steady decrease in the poverty rate for all the transfer simulations. Coloured individuals, on the other hand, actually experience an increase in poverty for the R80 and R120 transfer simulations due to the tax effect and the fact that Coloured people typically fall closer to the poverty line. There is virtually no change in the poverty rates among the Asian and White population. Despite having to pay higher taxes and probably not receiving much of

²⁰ In these simulations the increase in the tax rate was applied equiproportionately across all household groups and taxpayers.

the transfer these individuals are far enough from the poverty line to not be affected by increased taxes.

Figure 13: Poverty headcount ratios across racial groups

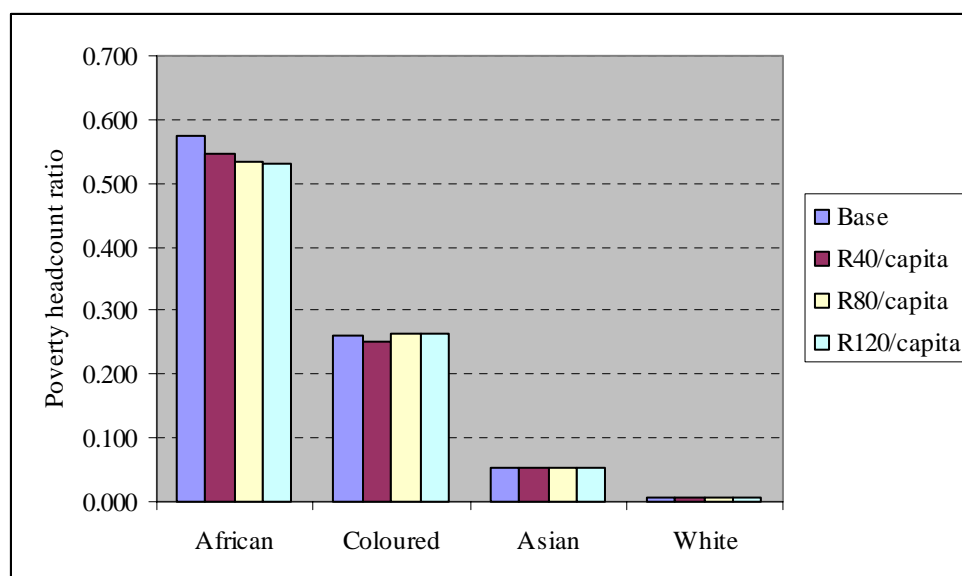

Note: See Figure 19 in the appendix (section 9.5) for a graph of the change in the depth of poverty.

Figure 14 shows the poverty headcount ratios by gender of the head of the household. Many female-headed households were recipients of the transfer, and hence it is not surprising to see a relatively large decline in the poverty rate among these households.

Figure 14: Poverty headcount ratios and the gender of the household head

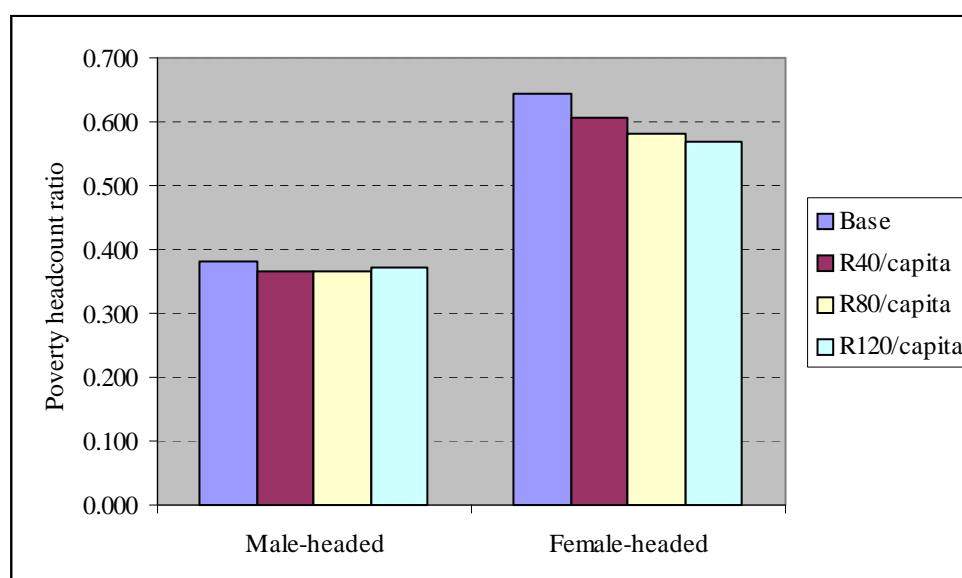

Note: See Figure 20 in the appendix (section 9.5) for a graph of the change in the depth of poverty.

The percentage change in the mean per capita income shown in Figure 15 is pulled directly from the CGE model results. The change is minimal, ranging from a drop of 1.1% to 1.3% in

the R40 and R120 simulations. This drop is consistent with earlier findings of a net welfare loss to households. In all the simulations we effectively increase taxes, which is paid mostly by middle- to high-income households, and use the revenue generated to finance transfers to poor households. A decline in inequality is therefore expected. Figure 15 shows various inequality estimates, namely the Theil-L and Theil-T indices, as well as the Gini coefficient. All show a decline in inequality as a result of the transfer. The difference between the R40, R80 and R120 transfer simulations is, however, quite small.

Figure 15: Changes in per capita income and inequality estimates

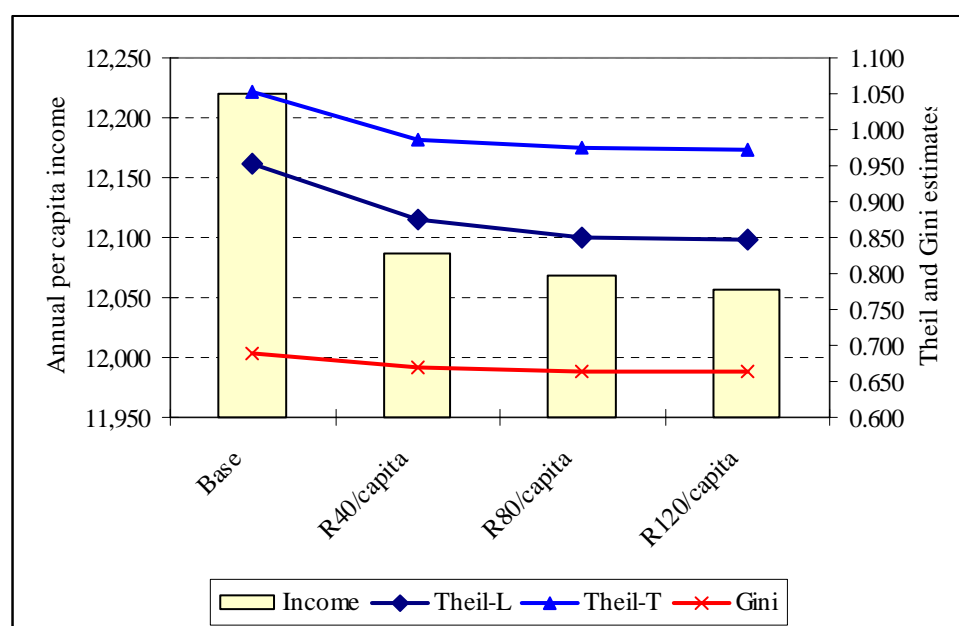

7. Conclusions

Despite widespread poverty there is general consensus among policymakers about the preference of targeted welfare transfers over non-targeted grants due to the budgetary implications of the latter. Targeting, however, adds to the administrative complexities of disbursing welfare grants, thus introducing a cost dimension that is as yet largely unexplored. Preliminary results suggest that the poverty impact of targeted welfare transfers with a budget of R15 billion is small: the poverty headcount falls from about 49% in the base to approximately 46% in the simulations. However, for some household groups poverty may actually increase due to the increases tax burden, also on households that are close to the poverty line. This highlights the importance of ensuring an equitable distribution of the increased tax burden. Inequality also declines marginally in all the simulations considered, mainly because poor households are targeted while non-poor households typically carry a larger share of the increased tax burden. In as far as the effectiveness of broad versus narrow targeting is concerned the results suggest that narrower targeting generally implies greater

reductions in poverty and inequality, although it depends crucially on the how far the transfer recipients are located from the poverty line.

8. References

- Armington, P.S. (1969). "A theory of demand for products distinguished by place of production," *IMF Staff Papers*, Vol. 16.
- Bhorat, H. and Leibbrandt, M. (1996). "Understanding Unemployment. The Relationship between the Employed and the Jobless." In *Against the Current. Labour and Economic Policy in South Africa*, edited by Baskin, J. Randburg: NALEDI.
- Decaluwé, B., Patry, A., Savard, L. and Thorbecke, E. (1999). "Poverty Analysis Within a General Equilibrium Framework," *CRÉFA Working Paper*, 9909.
- Dervis, K., de Melo, J. and Robinson, S. (1982). *General Equilibrium Models for Development Policy*. Cambridge University Press: New York.
- Devarajan, S., Lewis, J.D. and Robinson, S. (1994). "Getting the Model Right: The General Equilibrium Approach to Adjustment Policy," *Mimeo*.
- Estudillo, J.P. (1997). "Income Inequality in the Phillipines, 1961-91," *The Developing Economies*, XXXV(1): 68-95.
- Gravelle, H. and Rees, R. (1992). *Microeconomics*, 2nd. Prentice Hall: London.
- Haarmann, C. (2001a). "Poverty and the Current Social Assistance Programmes in South Africa," *Applied Fiscal Research Centre Research Monograph Series*, 21.
- Haarmann, C. (2001b). "Social Assistance Programmes: Options and Impact on Poverty and Economic Development in South Africa," *Applied Fiscal Research Centre Research Monograph Series*, 22.
- Hoogeveen, J.G. and Özler, B. (2004). "Not Separate, Not Equal. Poverty and Inequality in Post-Apartheid South Africa." World Bank.
- Kilkenny, M. (1991). "Computable General Equilibrium Modeling of Agricultural Policies: Documentation of the 30-Sector FPGE GAMS Model of the United States." USDA ERS Staff Report AGES 9125.
- Leibbrandt, M., Van der Berg, S. and Bhorat, H. (2001a). "Introduction." In *Fighting Poverty. Labour Markets and Inequality in South Africa*, edited by Bhorat, H., Leibbrandt, M., Maziya, M., Van der Berg, S. and Woolard, I. Cape Town: UCT Press.
- Leibbrandt, M., Woolard, I. and Bhorat, H. (2001b). "Understanding contemporary household inequality in South Africa." In *Fighting Poverty. Labour Markets and Inequality in South Africa*, edited by Bhorat, H., Leibbrandt, M., Maziya, M., Van der Berg, S. and Woolard, I. Cape Town: UCT Press.
- May, J. (1998). "Poverty and Inequality in South Africa," *Report prepared for the Office of the Executive Deputy President and the Inter-Ministerial Committee for Poverty and Inequality*.
- May, J., Carter, M.R. and Posel, D. (1995). "The composition and persistence of poverty in rural South Africa: an entitlements approach," *Land and Agricultural Policy Centre Policy Paper No. 15*.
- McDonald, S. and Punt, C. (2003). "The Impact of a Proposed Basic Income Grant on the Western Cape." *Paper presented at the 6th Annual Conference on Global Economic Analysis, The Hague*.
- Pauw, K. and Edwards, L. (2003). "Evaluating the General Equilibrium Effects of a Wage Subsidy Scheme for South Africa." *Paper presented at the Biennial Conference of the Economic Society of South Africa*, 17 - 19 September 2003, Somerset West.
- PROVIDE (2003a). "Measures of Poverty and Inequality. A Reference Paper," *PROVIDE Technical Paper Series*, 2003:4. PROVIDE Project, Elsenburg. Available online at www.elsenburg.com/provide.
- PROVIDE (2003b). "Multivariate Statistical Techniques," *PROVIDE Background Paper Series*, 2003:1. PROVIDE Project, Elsenburg. Available online at www.elsenburg.com/provide.
- PROVIDE (2005a). "Compiling a Social Accounting Matrix for South Africa: 2000," *PROVIDE Technical Paper Series*, Forthcoming. PROVIDE Project, Elsenburg.
- PROVIDE (2005b). "Creating an IES-LFS 2000 Database in Stata," *PROVIDE Technical Paper Series*, 2005:1. PROVIDE Project, Elsenburg. Available online at www.elsenburg.com/provide.
- PROVIDE (2005c). "Forming Representative Household Groups in a SAM," *PROVIDE Technical Paper Series*, 2005:2. PROVIDE Project, Elsenburg. Available online at www.elsenburg.com/provide.
- PROVIDE (2005d). "A profile of South Africa's provinces: Demographics, poverty, inequality and unemployment," *PROVIDE Background Paper Series*, 2005:1 (Volumes 1-10). Available online at www.elsenburg.com/provide.

- PROVIDE (2005e). "The PROVIDE Project Standard Computable General Equilibrium Model. Version 2.," *PROVIDE Technical Paper Series*, 2005:3. PROVIDE Project, Elsenburg. Available online at www.elsenburg.com/provide.
- PROVIDE (2005f). "Quantifying the economic divide in South African agriculture: An income-side analysis," *PROVIDE Technical Paper Series*, 2005:3. PROVIDE Project. Available online at www.elsenburg.com/provide.
- Pyatt, G. (1998). "A SAM Approach to Modelling," *Journal of Policy Modelling*, 10: 327-352.
- Republic of South Africa (1996). *Growth, Employment and Redistribution. A Macroeconomic Strategy*, Pretoria.
- Robinson, S., Kilkenny, M. and Hanson, K. (1990). "USDA/ERS Computable General Equilibrium Model of the United States." USDA ERS Staff Report AGES 9049.
- SALDRU (1994). *Project for Statistics on Living Standards and Development (PSLSD), 1993*, Cape Town: South African Labour and Development Research Unit in co-operation with the World Bank.
- SSA (1997). *Household Income and Expenditure Survey, 1995*, Pretoria: Statistics South Africa.
- SSA (2002a). *Income and Expenditure Survey 2000*, Pretoria: Statistics South Africa.
- SSA (2002b). *Labour Force Survey September 2000*, Pretoria: Statistics South Africa.
- SSA (2004). *Labour Force Survey, September 2003*, Pretoria: Statistics South Africa.
- Taylor, V. (2002). "Transforming the Present - Protecting the Future.," *Report of the Committee of Inquiry into a Comprehensive System of Social Security for South Africa*.
- Thurlow, J. (2002). "Can South Africa Afford to Become Africa's First Welfare State?," *International Food Policy Research Institute (IFPRI): Trade and Macroeconomics Division Discussion Paper*, 101.
- Van der Berg, S., Nieftagodien, S. and Burger, R. (2003). "Consumption patterns and living standards of the black population in perspective." *Paper presented at the Biennial Conference of the Economic Society of South Africa*, Somerset West.
- Woolard, I. (1998). "A Comparison of Urban Poverty," *Chapter prepared for the Poverty and Inequality Report*, edited by May, J.
- Woolard, I. and Leibbrandt, M. (2001). "Measuring Poverty in South Africa." In *Fighting Poverty. Labour Markets and Inequality in South Africa*, edited by Borat, H., Leibbrandt, M., Maziya, M., Van der Berg, S. and Woolard, I. Cape Town: UCT Press.

9. Appendix

9.1. Construction of representative household groups for the PROVIDE SAM

The formation of household groups for a Social Accounting Matrix is important. Rivero *et al.* (1986, cited in Decaluwé *et al.*, 1999) argue that certain requirements should be met if a certain classification is to be used in a SAM. Adapting these conditions to household groups in particular, he argues that the classification should (1) correctly reproduce the socio-economic stratification within the society and the economy; (2) distinguish relatively homogenous household groups and categories; (3) be composed of socio-economic groups that are recognisable for policy purposes, i.e. they should be distinguishable as target groups for policy experiments; (4) be based on comparatively stable characteristics that are reliable and easily measured; and (5) be derivable from (a combination of) existing data sources. The intention is to group households with similar income sources and expenditure patterns so that the representative household group assumption, which basically entails an assumption that all individual households within a household group are affected and react to economic shocks in the same, is as realistic as possible.

The formation of the 162 household groups in the South African SAM is discussed in detail in the *PROVIDE Project Technical Paper 2005:2* (PROVIDE, 2005c). The household accounts are disaggregated by province, race, farming/non-farming, homelands/non-homelands, gender of the head of the household, education level of the head of the household, and income of the household. The four regions that have been identified for the purpose of regional analyses within the PROVIDE Project are made up of between two and three provinces each. These are the West Coast (Western Cape, Northern Cape), East Coast (Eastern Cape, KwaZulu-Natal), Central (Free State, North West, Gauteng) and Border (Mpumalanga, Limpopo) regions.

The racial group and homeland/non-homeland distinction is driven by the history of South Africa. There are large differences in income levels and sources of income, expenditure patterns, and other characteristics between households of different racial groups. African households living in homeland areas are also typically more impoverished and isolated from the formal economy than non-homeland African households, hence this distinction in certain provinces. A further consequence of South Africa's past is the presence of 'fractured families'. The country has a very large share of female-headed households who are left to run the household while their husbands search for work on mines and in the cities. This has had important social implications, especially in rural areas, with husbands never returning or failing to fulfil their commitments in terms of supporting their families at home.

Education levels capture a skills dimension and improve the relationship between factor and household accounts.²¹ Evidence in South Africa suggests a high correlation between education levels and employment status (Bhorat and Leibbrandt, 1996), and also between unemployment and poverty (see for example May, 1998). Only very large groups were further split into low-income and high-income groups, with the cut-off point around the median of income within the larger group.

Obviously not all provinces or races can be disaggregated fully using these criteria due to limited numbers of observations for some of the criteria. For example, there are no homelands in the Western Cape, and too few farming households in the Northern Cape to justify having separate household groups for these. In most provinces Coloured and Asian households are also grouped together due to limited number of either or both of these households.

9.2. Poverty rates for various population sub-groups

In all the tables in this section the first row of each cell shows the percentage poor and non-poor people in the particular group (row sums to 100%), while the second row shows the proportion of all the poor that fall in the particular group (column sums to 100%). A poverty line of R3,864 per capita per annum is used throughout.

Table 12: Poverty rates and poverty distribution by race

	Poor	Non-poor	Total
African	57.55	42.45	100.00
	94.98	67.20	80.80
Coloured	25.91	74.09	100.00
	4.64	12.73	8.77
Asian	5.28	94.72	100.00
	0.26	4.52	2.43
White	0.72	99.28	100.00
	0.12	15.55	8.00
Total	48.96	51.04	100.00
	100.00	100.00	100.00

²¹ Education levels are (1) none- or pre-primary, (2) primary, (3) lower secondary (or grade 10), (4) upper secondary (or grade 12), (5) tertiary, and (6) don't know or missing value.

Table 13: Poverty rates and poverty distribution by province

	Poor	Non-poor	Total
Western Cape	21.72	78.28	100.00
	4.08	14.10	9.20
Eastern Cape	68.79	31.21	100.00
	20.50	8.92	14.59
Northern Cape	46.82	53.18	100.00
	1.47	1.60	1.53
Free State	55.45	44.55	100.00
	6.41	4.94	5.66
KwaZulu-Natal	57.57	42.43	100.00
	24.73	17.48	21.03
North West	52.64	47.36	100.00
	7.43	6.41	6.91
Gauteng	27.72	72.28	100.00
	13.61	34.05	24.04
Mpumalanga	52.17	47.83	100.00
	6.60	5.80	6.19
Limpopo	68.49	31.51	100.00
	15.17	6.70	10.85
Total	48.96	51.04	100.00
	100.00	100.00	100.00

Table 14: Poverty rates and poverty distribution by region

	Poor	Non-poor	Total
West Coast	25.31	74.69	100.00
	5.55	15.70	10.73
East Coast	62.17	37.83	100.00
	45.23	26.40	35.62
Border	62.56	37.44	100.00
	21.77	12.50	17.04
Central	36.71	63.29	100.00
	27.45	45.40	36.61
Total	48.96	51.04	100.00
	100.00	100.00	100.00

Table 15: Poverty rates and poverty distribution by location (a)

	Poor	Non-poor	Total
Urban	32.00	68.00	100.00
	37.51	76.48	57.40
Rural	71.82	28.18	100.00
	62.49	23.52	42.60
Total	48.96	51.04	100.00
	100.00	100.00	100.00

Table 16: Poverty rates and poverty distribution by location (b)

	Poor	Non-poor	Total
Metro	26.99	73.01	100.00
	18.53	48.07	33.61
Urban	39.16	60.84	100.00
	20.20	30.11	25.26
Rural	72.93	27.07	100.00
	61.27	21.82	41.14
Total	48.96	51.04	100.00
	100.00	100.00	100.00

Note: The column shares for metro plus urban ($18.53 + 20.20 = 38.73$) should in theory equal the column share for 'urban' in Table 15. However, some areas that are classified as 'rural' in the IES/LFS 2000 actually fall within the metropolitan boundaries.

Table 17: Poverty rates and poverty distribution in the former homelands (a)

	Poor	Non-poor	Total
Rest of SA	37.36 51.03	62.64 82.05	100.00 66.86
Bophuthatswana	48.52 2.34	51.48 2.38	100.00 2.36
Ciskei	62.58 2.10	37.42 1.20	100.00 1.64
Transkei	81.74 14.50	18.26 3.11	100.00 8.68
Venda	71.42 2.64	28.58 1.01	100.00 1.81
Qwaqwa	76.80 1.18	23.20 0.34	100.00 0.75
Gazankulu	68.86 4.03	31.14 1.75	100.00 2.86
KwaZulu	76.81 10.25	23.19 2.97	100.00 6.53
KwaNdebele	64.46 1.70	35.54 0.90	100.00 1.29
Lebowa	71.62 7.85	28.38 2.98	100.00 5.36
KaNdwane	63.77 2.39	36.23 1.30	100.00 1.84
Total	48.96 100.00	51.04 100.00	100.00 100.00

Table 18: Poverty rates and poverty distribution in the former homelands (b)

	Poor	Non-poor	Total
Rest of SA	37.36 51.03	62.64 82.05	100.00 66.86
Homelands	72.36 48.97	27.64 17.95	100.00 33.14
Total	48.96 100.00	51.04 100.00	100.00 100.00

Table 19: Poverty rates and poverty distribution by gender

	Poor	Non-poor	Total
Male	46.32	53.68	100.00
	45.05	50.08	47.61
Female	51.36	48.64	100.00
	54.95	49.92	52.39
Total	48.96	51.04	100.00
	100.00	100.00	100.00

Table 20: Poverty rates and poverty distribution by age groups

	Poor	Non-poor	Total
Under 15	60.81	39.19	100.00
	40.29	24.91	32.44
Over 15	43.27	56.73	100.00
	59.71	75.09	67.56
Total	48.96	51.04	100.00
	100.00	100.00	100.00

Table 21: Poverty rates and poverty distribution by gender of the household head

	Poor	Non-poor	Total
Male-headed	38.00	62.00	100.00
	45.36	70.98	58.43
Female-headed	64.36	35.64	100.00
	54.64	29.02	41.57
Total	48.96	51.04	100.00
	100.00	100.00	100.00

Table 22: Poverty rates and poverty distribution by education level of the household head

	Poor	Non-poor	Total
No educ/unknown	75.52	24.48	100.00
	34.88	10.83	22.60
Primary	62.30	37.70	100.00
	40.87	23.68	32.09
Lower secondary	38.66	61.34	100.00
	17.84	27.11	22.57
Upper Secondary	16.77	83.23	100.00
	6.31	30.01	18.42
Tertiary	1.13	98.87	100.00
	0.10	8.38	4.33
Total	48.92	51.08	100.00
	100.00	100.00	100.00

9.3. Employment impact and the deficit financing closure

The large decline in investment under the deficit financing option has a relatively large impact on employment in industries that primarily produce investment-type commodities. Approximately 90% of total investment expenditure is on four commodity groups in our model, namely machinery (*cmach*), vehicles (*cvehic*), other manufacturing (*cmanuf*) and construction and building (*cconst*). The construction industry is a good example of an industry to illustrate the potential employment impact resulting from a large decline in investment. This industry has a number of unique features (data from the model SAM):

- It employs a relatively large proportion of workers in South Africa (approximately 4.3%).
- It attracts a large share of investment expenditure in South Africa (38%).
- Being a service it does not compete with imports.
- A relatively large share of the construction and buildings (58%) is sold as investment expenditure in the SAM; the rest is made up of intermediate input expenditure and final household consumption demand.
- Despite allowing for multi-product activities about 99% of the ‘commodity’ construction and buildings is supplied by the construction and buildings activity.

Given these circumstances a large decline in total investment is likely to have a relatively large employment effect in the construction and buildings industry. In fact, results suggest that under the deficit financing closure, which assumes full employment but mobility across sectors, employment in the construction industry declines by 7.4% and 9.4% for *sim01* and *sim06*. Under the tax replacement closure, also with full employment, the decline is only 0.4% (both simulations).

9.4. Accounts in the SAM

Table 23: Accounts in the model SAM

Account name	Description	Account name	Description
Commodities		Activities continued...	
cfield	Field crops	agnwest	Agric North West
chort	Horticulture	agfstat	Agric Free State
clstoc	Livestock and other animals	agecap	Agric East Cape
cfors	Forestry and other agric products	agkzn	Agric KwaZulu Natal
cmins	Mineral products	agmpum	Agric Mpumalanga
cmeat	Meat products	aglimp	Agric Limpopo
cfiprod	Processed fish products	aggaut	Agric Gauteng
cfruveg	Fruit and vegetable products	aforest	Forestry
Coils	Oils and fats products	afish	Fishing
cdairy	Dairy products	amins	Minerals
cgrain	Grain mill products	ameat	Meat products
cafeed	Animal feeds	afishp	Fish products
cbake	Bakery products	afruit	Fruit
csugar	Sugar products	aoils	Oils
cofood	Other food products	adairy	Dairy products
cbevs	Beverages and tobacco	agrain	Grain mills
ctext	Textile products	aafeed	Animal feeds
clwpap	Leather wood and paper products	abake	Bakeries
cpetro	Petroleum products	asugar	Sugar
Cfert	Fertilisers	aofood	Other food products
pcides	Pesticides	abev	Beverages and tobacco
cpharm	Pharmaceutical products	atext	Textiles
ochem	All other chemical products	alwpap	Leather Wood and Paper
cnonmet	Non metallic products	apetro	Petroleum
cmetprod	Metal products	afert	Fertilisers
cmach	Machinery	apest	Pesticides
cvehic	Vehicles	apharm	Pharmaceuticals
comanu	Other manufacturing	aochem	Other Chemicals
Cutil	Utilities	anonmet	Non metallics
cconst	Construction and building	ametals	Metals
ctraserv	Trade and transport services	amach	Machinery
coserv	Other services	avehic	Vehicles
Transport margins		aomanu	Other manufacturing
marg	Margins	autil	Utilities
Activities		aconst	Construction and Building
agwcap	Agric W Cape	atrad	Trade and transport services
agncap	Agric North Cape	aoserv	Other services

Table 23 continued...

Account name	Description	Account name	Description
Factors		Factors continued	
Egos	Gross operating surplus	fgtafskil	GT Skilled African labour
fland	Land	fgtafsemi	GT Semi skilled African labour
fwcafskil	WC Skilled African labour	fgtafunsk	GT Unskilled African labour
fwcafuns	WC Semi and Un skilled African labour	fgtcolab	GT Coloured labour
fwccoskil	WC Skilled Coloured and Asian labour	fgtaslab	GT Asian labour
fwccounsk	WC Unskilled Coloured labour	fgtwhskil	GT Skilled White labour
fwccofm	WC Farm Coloured and Asian labour	fgtwhunsk	GT Unskilled White labour
fwcwhskil	WC Skilled White labour	fmpafskil	MP Skilled African labour
fwcwhunsk	WC Unskilled White labour	fmpafsemi	MP Semi skilled African labour
fecafskil	EC Skilled African labour	fmpafunsk	MP Unskilled African labour
fecafunsk	EC Unskilled African labour	fmpcolab	MP Coloured and Asian labour
fecaffm	EC Farm African labour	fmpwhskil	MP Skilled White labour
feccoasskil	EC Coloured and Asian skilled labour	fmpwhunsk	MP Unskilled White labour
feccounsk	EC Coloured and Asian unskilled	flpafskil	LP Skilled African labour
fecwhskil	EC Skilled White labour	flpafsemi	LP Semi skilled African labour
fecwhunsk	EC Unskilled White labour	flpafunsk	LP Unskilled African labour
fncaflab	NC African labour	flpcolab	LP Coloured and Asian labour
fnccolab	NC Coloured and Asian labour	flpwhlab	LP White labour
fnwhlab	NC White labour	Government accounts	
ffsafskil	FS Skilled African labour	VATM	Value added taxes in imports
ffsafunsk	FS Unskilled African labour	VATD	Value added taxes on domestic goods
ffscolab	FS Coloured and Asian labour	IMPTAX	Import duties
ffswhskil	FS Skilled White labour	EXPTAX	Export taxes
ffswhunsk	FS Unskilled White labour	ECTAX	Excise duty
fkznafskil	KZN Skilled African labour	FUELTAX	Fuel Tax
fkznafsemi	KZN Semi skilled African labour	SALTAX	Sales taxes
fkznafunsk	KZN Unskilled African labour	SALSUB	Sales subsidies
fkznaffm	KZN Farm African labour	INDREF	Production rebates
fkzncolab	KZN Coloured labour	INDTAX	Production taxes
fkznasskil	KZN Skilled Asian labour	INDSUB	Production subsidies
fkznasunsk	KZN Unskilled Asian labour	FACTTAX	Factor taxes
fkznwhskil	KZN Skilled White labour	DIRTAX	Direct income taxes
fkznwhunsk	KZN Unskilled White labour	GOVT	Government
fnwafskil	NW Skilled African labour	Other accounts	
fnwafsemi	NW Semi skilled African labour	ENT	Enterprises
fnwafunsk	NW Unskilled African labour	KAP	Savings
fnwcolab	NW Coloured labour	DSTOC	Stock Changes
fnwhlab	NW White labour	ROW	Rest of World

9.5. Welfare effects – additional graphs

Figure 16: Household expenditure changes by province

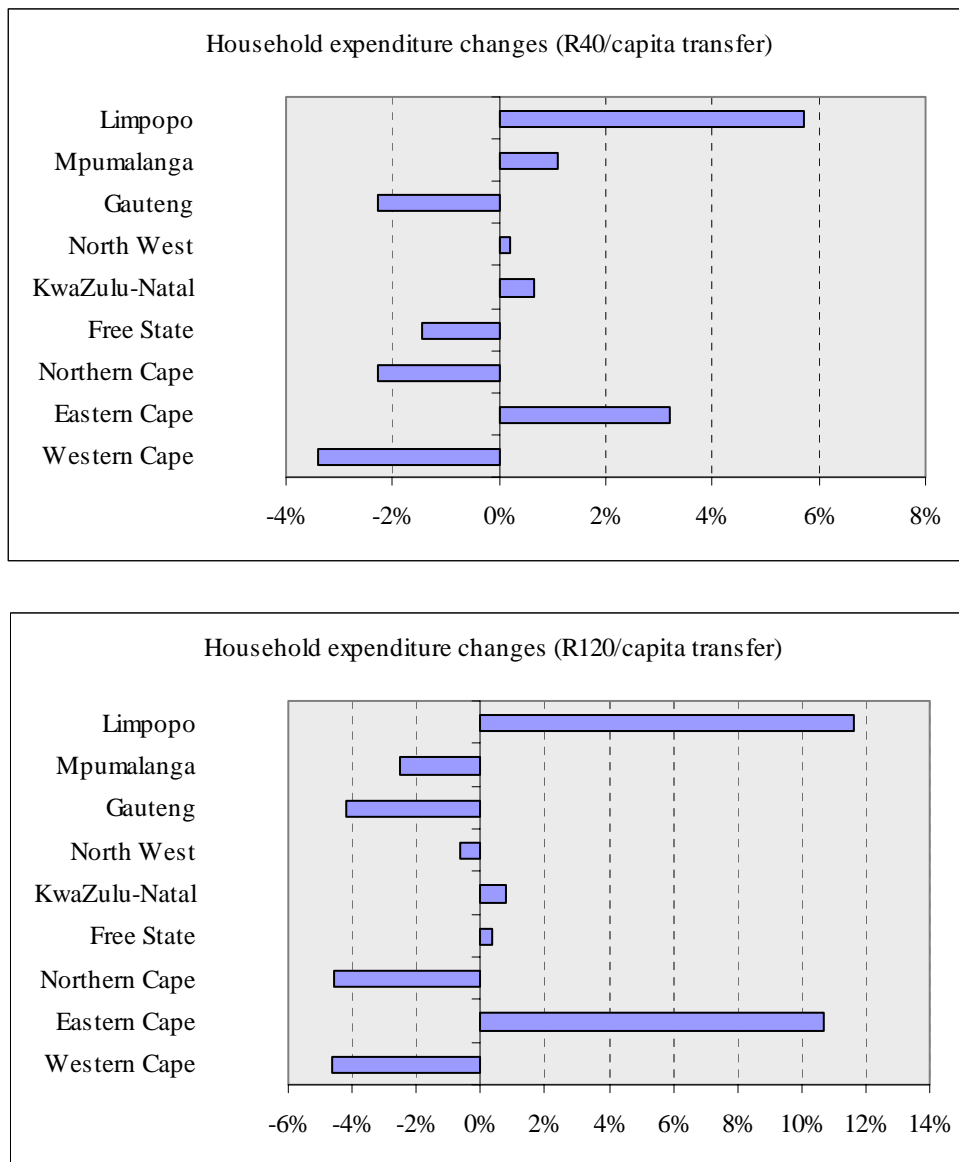

Note: Compare Figure 9 in the text.

Figure 17: Comparing consumption effects between targeted and non-targeted households

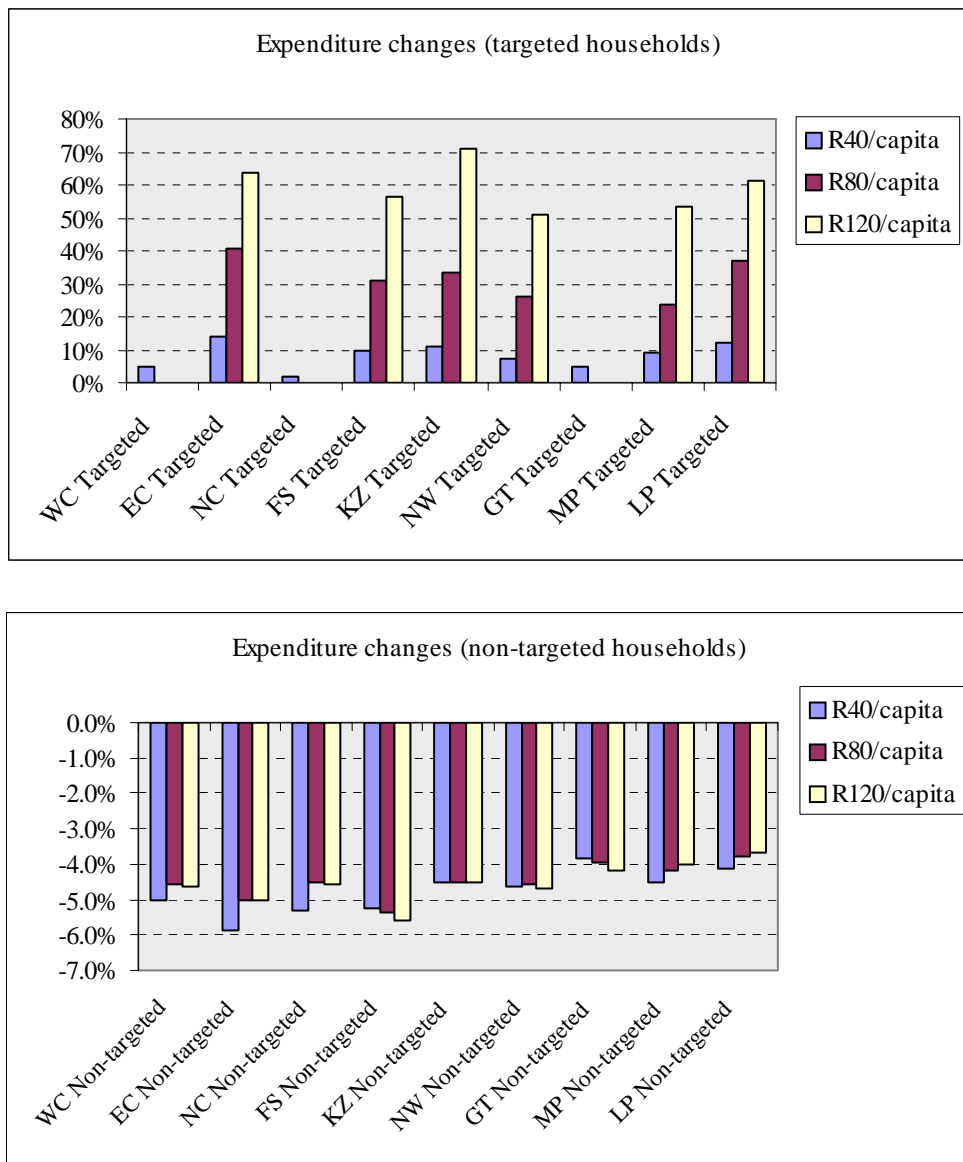

Note: Compare Figure 10 in the text.

Figure 18: Regional-level depth of poverty

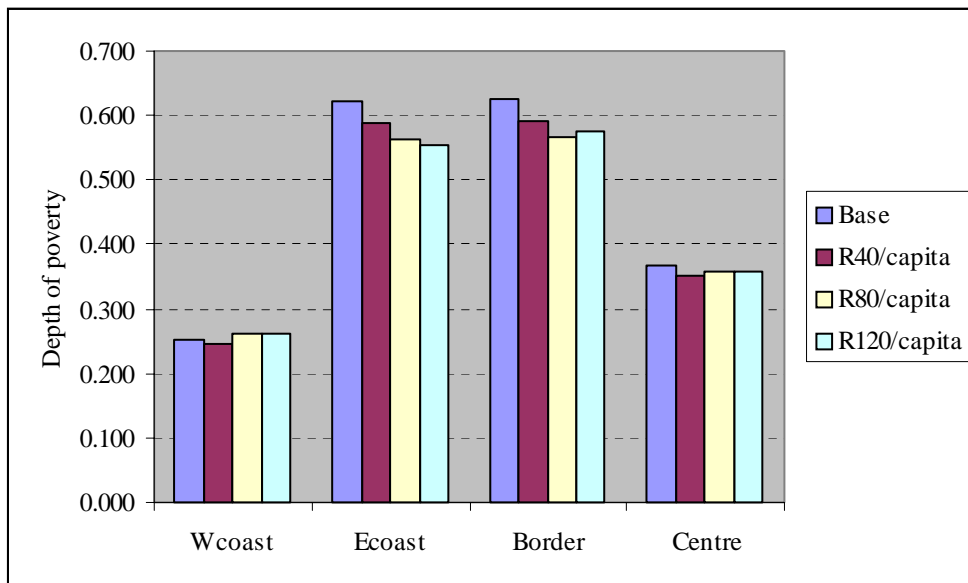

Note: Compare Figure 12 in the text.

Figure 19: Depth of poverty across racial groups

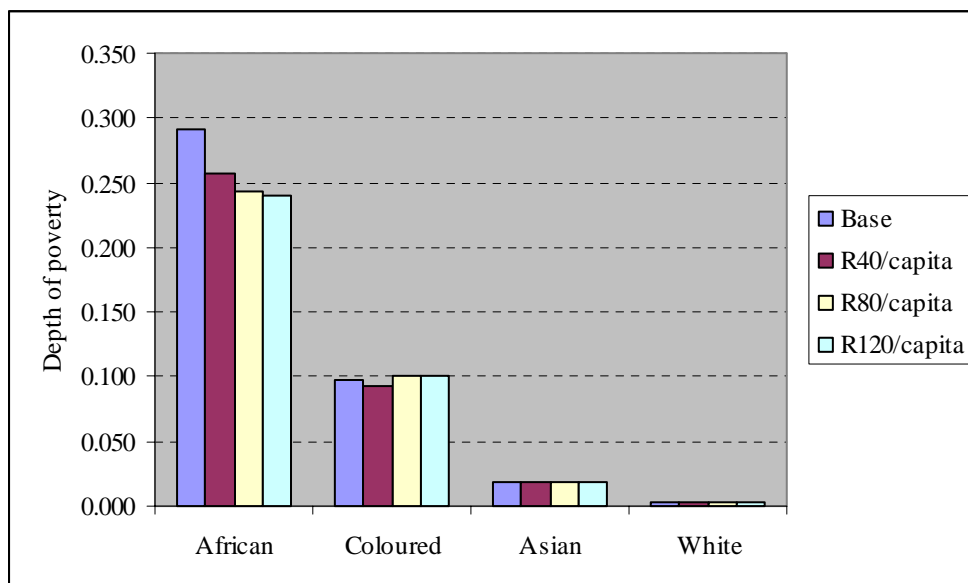

Note: Compare Figure 13 in the text.

Figure 20: Depth of poverty and the gender of the household head

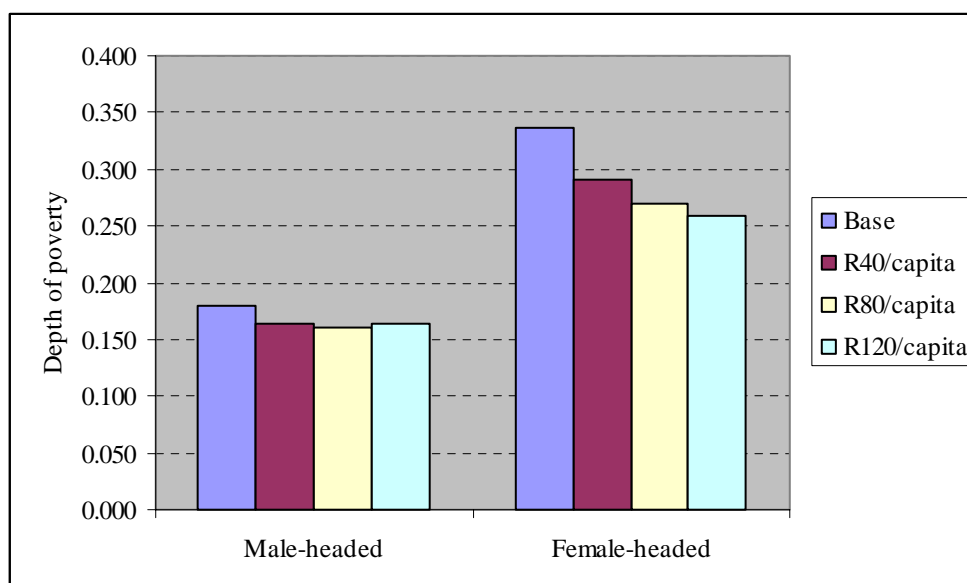

Note: Compare Figure 14 in the text.

9.6. Technical notes on dataset, weights and variables

All poverty rates calculated in Stata® dataset *ieslfsmerge.dta*. A poverty line of R3,864 per capita per annum (R322 per capita per month) – Hoogeveen and Özler's (2004) lower bound poverty line – is used (variable *pctotinc*). Variable *weight* is used throughout as the sampling weight (*gen wgtselect = weight*) rather than *mergepwt*. Variable *weight* will correctly reproduce the population estimates in the base-SAM. Use percentage changes in per capita incomes from the CGE model to calculate the effective change in the IES/LFS 2000 per capita income. Percentage changes are used since per capita income in the IES/LFS 2000 database and the SAM are NOT consistent in the base due to balancing in the SAM.

Working Papers in this Series

Number	Title	Date
WP2004:1	Trade Liberalisation, Efficiency, and South Africa's Sugar Industry	July 2004
WP2004:2	The Welfare Impacts of Domestic and International Agricultural Efficiency Gains: A South African Case Study	December 2004
WP2005:1	The Impact of Oil Price Increases in the South African Economy	February 2005
WP2005:2	Costs and Benefits of Higher Tariffs on Wheat Imports – A General Equilibrium Analysis	April 2005
WP2005:3	Quantifying the economic divide in South African agriculture: An income-side analysis	September 2005
WP2005:4	The impact of a higher fuel levy on the Western Cape	November 2005
WP2005:5	General Equilibrium Effects in the South African Maize Market: International Trade Simulations	November 2005
WP2005:6	The welfare impacts of targeted transfers to poor households	November 2005

Other PROVIDE Publications

Technical Paper Series
Background Paper Series
Research Reports