

**Working Paper Series**

**PROVIDE**  
PROJECT  
The Provincial Decision-making Enabling Project

**Working Paper 2004: 1**

**Trade Liberalisation, Efficiency  
and South Africa's Sugar  
Industry**

*Eisenburg  
July 2004*

# PROVIDE

# PROJECT

The Provincial Decision-making Enabling Project

## Overview

The Provincial Decision-Making Enabling (PROVIDE) Project aims to facilitate policy design by supplying policymakers with provincial and national level quantitative policy information. The project entails the development of a series of databases (in the format of Social Accounting Matrices) for use in Computable General Equilibrium models.

The National and Provincial Departments of Agriculture are the stakeholders and funders of the PROVIDE Project. The research team is located at Elsenburg in the Western Cape.

## PROVIDE Research Team

Project Leader:	Cecilia Punt
Senior Researchers:	Kalie Pauw Melt van Schoor
Junior Researchers:	Benedict Gilimani Lillian Rantho Rosemary Leaver
Technical Expert:	Scott McDonald
Associate Researchers:	Lindsay Chant Christine Valente

## PROVIDE Contact Details

 Private Bag X1  
Elsenburg, 7607  
South Africa

 [ceciliap@elsenburg.com](mailto:ceciliap@elsenburg.com)

 +27-21-8085191

 +27-21-8085210

For the original project proposal and a more detailed description of the project, please visit [www.elsenburg.com/provide](http://www.elsenburg.com/provide)

# **Trade Liberalisation, Efficiency and South Africa's Sugar Industry<sup>1</sup>**

## **Abstract**

This paper reports the results of a computable general equilibrium (CGE) analysis of the South African sugar industry. The study was inspired by analyses of the EU South Africa Free Trade Agreement that indicated the importance of sugar exports to the welfare gains from agricultural trade liberalisation and by the increasing pressure upon OECD countries to reform their sugar (trade) policies. In addition to the effects of trade liberalisation this study also considers the implications of increases in the efficiency with which sugarcane is converted to raw sugar, which is an important determinant of the competitiveness of sugar production and exports. The results indicate that there would be substantial welfare gains across all household groups and that overall agricultural producers in South Africa should benefit; however there are substantial variations in the impact upon agricultural producers in different provinces, with farmers in some provinces facing reductions in the profitability of farming.

---

<sup>1</sup> The main authors of the paper are Dr Scott McDonald, technical advisor to the project, Cecilia Punt, Project Leader, and Rosemary Leaver, Junior Researcher to the PROVIDE Project.

## Table of contents

<b>TRADE LIBERALISATION, EFFICIENCY AND SOUTH AFRICA'S SUGAR INDUSTRY .....</b>	<b>I</b>
1. INTRODUCTION .....	1
2. THE SOUTH AFRICAN SUGAR INDUSTRY .....	2
2.1. Sugar Milling and Refining .....	5
2.2. Cane Payment System.....	5
2.3. Production process.....	6
3. COMPUTABLE GENERAL EQUILIBRIUM MODEL AND DATA .....	7
3.1. Computable General Equilibrium Model.....	7
3.2. The Data.....	18
4. POLICY ANALYSIS .....	19
4.1. Policy Scenarios.....	19
4.2. Model Closure Rules .....	19
4.3. Results and Analyses .....	21
5. CONCLUSIONS .....	31
6. REFERENCES .....	32
7. APPENDIX .....	34

## List of figures

Figure 1: South African Sugar Producing and Processing Regions .....	3
Figure 2: South Africa's Total Raw Sugar Production from 1989 to 2002.....	4
Figure 3 South African Crop Data: Total Cane to Sugar Ratio and Sucrose Percentage of Cane for the 1989 to 2003 Seasons.....	7
Figure 4: Price Relationships for a Standard Model.....	16
Figure 5: Quantity Relationships for a Standard Model.....	17
Figure 6: GDP and the Exchange Rate – Small vs Large Country Assumption with 10 percent change in TCTS .....	22
Figure 7: Price of Value Added (PVA) for Agriculture and Sugar Processing – Small Country Assumption without change in TCTS .....	23
Figure 8 Price of Value Added (PVA) for Agriculture and Sugar Processing – Small Country Assumption with 10 percent change in TCTS.....	24
Figure 9 Prices of Agricultural Commodities Sold on the Domestic Market– Small Country Assumption with and without 10 percent change in TCTS.....	25
Figure 10: Activity Prices for Agricultural Activities – Small Country Assumption with and without 10 percent change in TCTS .....	26
Figure 11: Factor Demand by Agriculture for 30 percent Change in World price with and without 10 percent Change in TCTS– African Labour.....	27
Figure 12: Factor Demand by Agriculture for 30 percent Change in World price with and without 10 percent Change in TCTS– Coloured Labour .....	27
Figure 13: Factor Demand by Agriculture for 30 percent Change in World price with and without 10 percent Change in TCTS– White Labour .....	28
Figure 14: Household Welfare with Small Country Assumption.....	29
Figure 15: Household Welfare with Large Country Assumption.....	29
Figure 16: Selected Consumer Price Changes with Small Country Assumption (%).....	30
Figure 17: Selected Consumer Price Changes with Large Country Assumption (%) .....	31

**List of tables**

Table 1: Behavioural Relationships for the Standard Model..... 10  
Table 2: Transactions Relationships for the Standard Model..... 13  
Table 3: Fully Employed and Unemployed Labour Categories..... 21  
Table 4: SAM Accounts for this Study..... 34

## 1. Introduction

Sugar is a basic foodstuff that is consumed in all countries. Although it cannot be considered a dietary staple, as can rice and maize, raw sugar is nonetheless regarded as an essential food commodity by many governments. The sugar industry has a number of key characteristics that differ markedly to those of other agricultural commodities. These relate to its trade structures, production characteristics, and associated political economy issues. It is because of these characteristics that the sugar industry provides an interesting case study that warrants special attention.

Firstly, there are severe distortions in world sugar markets as a result of government policy interventions and preferential trade agreements. Policy interventions take the form of both tariff and non-tariff barriers to trade. The result of these distortions is that sugar trade is not governed by the price signals that usually accompany the normal forces of supply and demand. Secondly, the physical characteristics of sugar production provide a multiplier for economic growth through forward and backward linkages with other sectors in the economy. These linkages promote economic diversification. A further related aspect is that sugar has joint production characteristics, meaning that the growth, storage and processing of sugar cane are interdependent activities. This is unlike most agricultural crops, for which the production, storage and processing are independent activities, with markets existing for both the processed and unprocessed product. Finally, sugar is a political commodity, around which numerous political economy issues abound, both between and within countries.

South Africa produces an average of 2.5 million tons of raw sugar per season, of which approximately 50 percent is exported to markets in Africa, Asia, the Middle East, North America and Europe. For example, in the 2002/2003 season, South Africa exported almost 1.5 million tons of raw sugar, making it the world's seventh largest exporter of raw sugar ([www.illovosugar.co.za](http://www.illovosugar.co.za)). The remainder is marketed in the South African Customs Union (SACU), the group of countries comprising of South Africa, Swaziland, Lesotho, Botswana and Namibia. Thus, the South African sugar industry plays an important role at the international, national and regional levels. Furthermore there is evidence (McDonald and Walmsley, 2004) that suggests that the export performance of the South African sugar industry may be an important determinant of any welfare gains for South Africa achieved through the bilateral and/or multilateral liberalisation of food and agricultural trade.

If the on-going attempt to liberalise world agricultural trade via the World Trade Organisation, witness the discussion at Doha and Cancun, are to prove successful then sugar is one of those commodities that is likely to experience substantial changes in prices and trade flows, although it is also one of the most contentious commodities. South Africa, as one of the

world's larger sugar producers, would expect that substantial changes in the global sugar market are likely to have non trivial implications for the South African economy. The analyses reported in this paper are conducted under the assumption that there is some liberalisation of world sugar trade, which in line with other studies is presumed to cause the world (traded) price of sugar to rise and with the price rise that South Africa's export opportunities will increase. The response of the sugar industry is complicated by complex interactions between the sugar cane growers and the cane processing factories. A crucial dimension of the efficiency of sugar production is the tonnes of cane required to produce a tonne of raw sugar (TCTS); hence the analyses in this paper also consider the impact of improvements in the TCTS ratio. This could be conceived of as a consequence of the pro-competitive impact of trade liberalisation.

The rest of this paper is organised as follows. The next section looks in more detail at the South African sugar market. In section 3 the computable general equilibrium (CGE) model and the data used for these analyses are outlined. The core of the paper is section 4: this starts with a description of the policy scenarios that are simulated, followed by descriptions of the model's closure rules that are used for the simulations and then the results of the simulations are discussed. The discussion of the results focuses on both the internal effects and the trade effects. The final section provides some concluding comments and suggestions for future explorations.

## **2. The South African Sugar Industry**

The sugar industry is a key agricultural sector within the South African economy, both in terms of production and employment. South Africa was the seventh largest exporter of raw sugar in 2002/2003, making a significant contribution to the country's foreign exchange earnings. The industry is responsible for providing direct employment in cane production and cane processing, whilst simultaneously creating indirect employment in various support industries such as the chemicals and fertilisers, transport and food sectors.

Sugar cane is grown in an area that extends from the Northern Pondoland in the Eastern Cape through KwaZulu-Natal to the Mpumalanga Lowveld. There are a total of 15 sugar mills, of which 13 are located in KwaZulu-Natal and the remainder in Mpumalanga province. South Africa's sugar producing regions are shown in Figure 1.

**Figure 1: South African Sugar Producing and Processing Regions**



Source: South African Sugar Association, 2003, page 2.

Since 1996, an average of 22 million tons of sugar cane has been delivered to the mills each season, from which 2.5 million tons of raw sugar is extracted. Figure 2 shows South Africa’s raw sugar production since 1989. Note the decline in raw sugar production between 1992 and 1996, the result of the severe four-year drought that affected South Africa during this period.

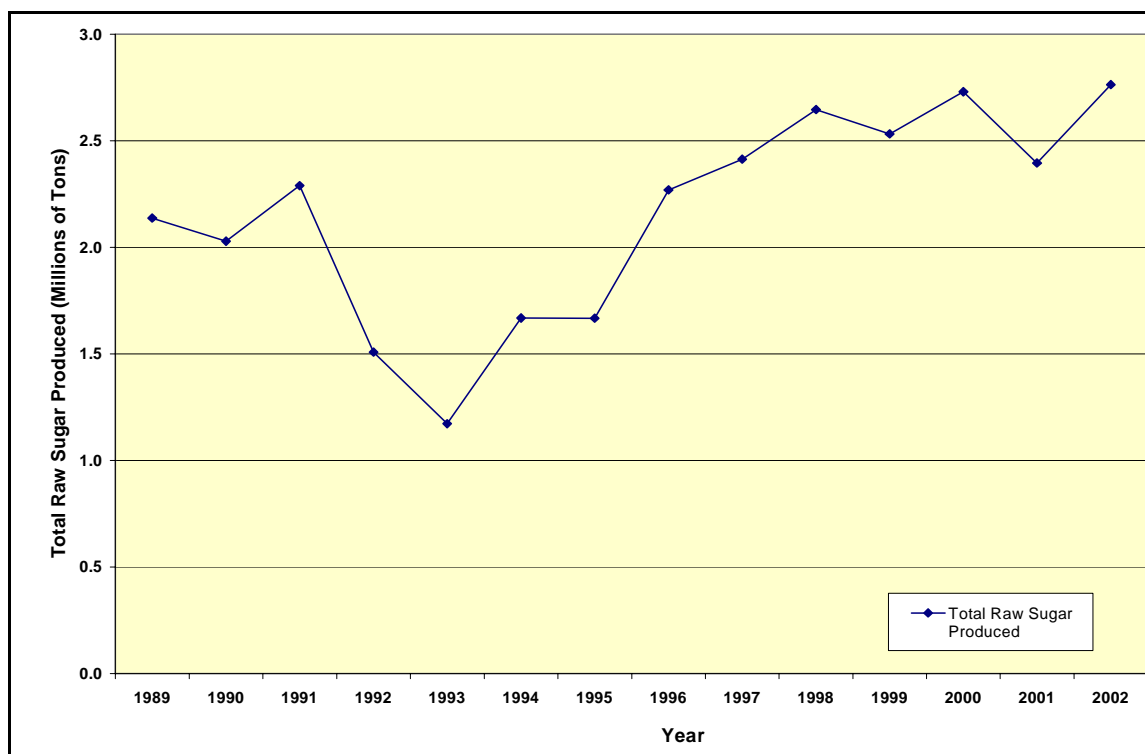
**Figure 2: South Africa's Total Raw Sugar Production from 1989 to 2002**

Source: South African Sugar Association, 2003.

There are approximately 50 000 registered sugar cane growers, of whom 48 000 are classified as small-scale growers (SSG's). SSG's are defined by Bates and Sokhela (2003: 105) as growers who produce less than 2 100 tons of sugar cane per season, whilst the South African Canegrowers Association describes them as those growers who currently deliver on average not more than 225 tonnes of Recoverable Value (RV) per year. The reason for this cutoff is that this tonnage would require a maximum of about 40 hectares (Bates & Sokhela, 2003:105). In the 2001–2002 season, SSG's "produced 14.4% of the sugar cane crop on 19.7% (85 418 hectares) of sugar cane land" (Bates and Sokhela, 2003: 105). The majority of SSGs produce sugar cane in the communal areas surrounding the Amatikulu, Felixton, Entumeni, and Umfolozi mills in KwaZulu-Natal (see Figure 1). In contrast, there are approximately 2,000 large-scale growers who account for 75 percent of total sugar cane production. Milling companies who own their own sugar estates produce the remaining 11 percent of the crop. However, according to SASA (2003), this percentage has decreased over the past few years as the milling companies have attempted to promote economic development amongst previously disadvantaged people by making farms available to medium-scale farmers at market-related prices. There are likely to be increasing pressures to increase the number of SSG in response to the acceleration of the land reform/redistribution programme in South Africa following the 2004 elections.

## 2.1. Sugar Milling and Refining

The South African Sugar Millers' Association Limited oversees the interests of all sugar millers and refiners in South Africa. Of the country's 15 sugar mills, seven are owned by Illovo Sugar Ltd, five by Tongaat-Hulett Sugar Ltd, two by Transvaal Sugar Ltd, and one is a co-operative, the Union Co-operative Ltd (Illovo, 2003: 7). The two Transvaal Sugar Ltd mills are located in Mpumalanga province, whilst the remaining mills are located in KwaZulu-Natal.

Five of the mills are termed "white end" mills, meaning that they produce their own refined sugar. The raw sugar produced by Transvaal Sugar Ltd is exported via the sugar terminal in Maputo, whilst the raw sugar produced at the remaining mills is routed to Durban where it is either refined at the central refinery of Tongaat-Hulett Sugar Ltd or stored at the Sugar Association sugar terminal prior to export.

The domestic market is supplied by the local sugar industry, as well as by imports from other countries. There is a market access allowance for sugar imports from Zimbabwe, Zambia and Malawi under the South African Development Community (SADC) agreement. Sugar from Swaziland is allowed in free of duty, due to its membership of SACU. However, this is subject to a quantity limitation, believed to be 250 000 tons, although this has not been confirmed by the sugar industry (USDA, FAS, GAIN Report, 2003).

The domestic market for raw sugar consists of two segments: the consumer market and the industrial market. The majority of raw sugar sales are to the consumer market, which comprises mostly of sales to wholesalers and chain stores. The main consumers in the industrial market are minerals and squashes firms, i.e., the beverages industry, bakers and food processors, and sweets manufacturers. The average South African consumes about 32 kilograms of raw sugar per annum.

## 2.2. Cane Payment System

In South Africa, as in many other countries, there is conflict between growers and millers over a number of issues, most of which relate to the interdependency of sugar production and processing. Of particular contention is the payment for cane delivered to millers, based on its quality. Due to its long harvesting season of approximately 9 months, and combined with weather conditions that lead to significant variation in cane quality over the length of the season, the issue of cane quality payment has always been linked by growers to the length of the milling season (LOMS), a factor which is beyond growers' control.

In an attempt to create incentives for the growing and milling sectors to work together to ensure cost competitive sugar production, a cane quality system was introduced in April 2000.

The Recoverable Value (RV) payment system enhanced the incentives for growers to improve cane quality by more accurately rewarding them for the estimated value of the cane they delivered to millers. The amount of sugar that can be extracted from cane during the milling process is dependent not only on the amount of sucrose in cane, but also on the amount of non-sucrose and fibre that it contains. This factor is accounted for in the RV system, which includes the percentage of sucrose, non-sucrose, and fibre in the cane.

The RV formula is represented as follows (www.sacanegrowers.co.za , 2004):

$$RV = S - dN - cF$$

where  $S$  = sucrose percentage of cane delivered;

$N$  = non sucrose percentage of cane delivered;

$d$  = the relative value of sucrose lost from sugar production per unit of non-sucrose, taking into account the value of molasses recovered per unit of non-sucrose;

$F$  = fibre percentage of cane delivered;

$c$  = the loss of sucrose from sugar production per unit of fibre.

The coefficients  $d$  and  $c$  are approximately 0.42 and 0.02 respectively, indicating the higher importance of non-sucrose on cane quality relative to fibre. The  $c$  coefficient is calculated annually based on a three season moving average, whilst the  $d$  coefficient is calculated monthly based on a three season moving average and current sugar and molasses price estimates.

The cane price is determined by the cane quality, or what is termed the “RV percent” of the cane. Cane quality is determined by the freshness, maturity and cleanliness of the cane delivered to the mill, as well as by the size of the crop, world market price, exchange rate, and the performance of the domestic market.

### 2.3. Production process

The production of raw sugar requires the close coordination of cane growing and cutting with milling. Ideally sugarcane would be cut at the time in its growing cycle where the recoverable sugar content was at its greatest, but milling is a highly capital intensive activity and consequently profitable operation of sugar mills requires running the mills over an extended season, hence cane is cut over a long period of time (up to 9 months) despite the fact that the sugar yield varies over that period. In addition the profitability of milling is heavily influenced by the time lapse between cutting and processing the cane; the yield of raw sugar from a given quantity of sugarcane declines the longer the period between cutting and processing, with the rate of decline increasing rapidly. A key indicator of the efficiency of (integrated) sugar

production is therefore the quantity of cane required to produce a tonne of raw sugar, the so-called Tonnes Cane to Tonnes Sugar (TCTS) ratio. Since 1989 the TCTS ratio for South Africa has been between 8.5 and 10 (SASA, 2003) (see Figure 3).

**Figure 3 South African Crop Data: Total Cane to Sugar Ratio and Sucrose Percentage of Cane for the 1989 to 2003 Seasons**

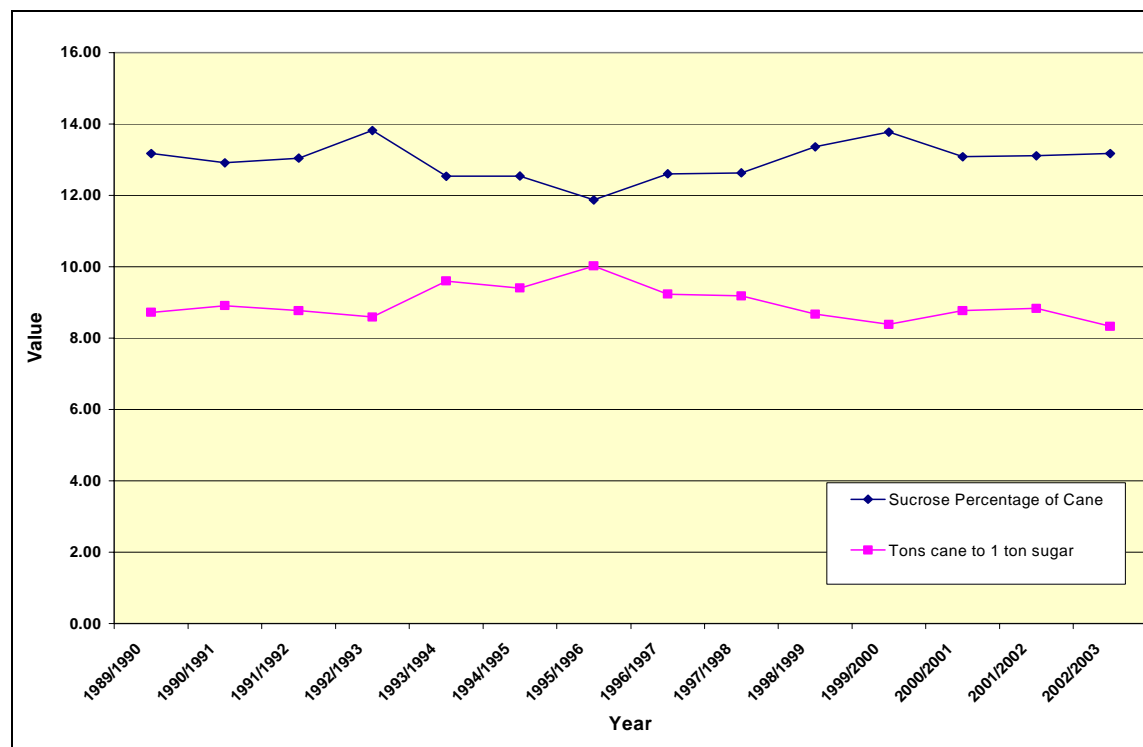

Source: South African Sugar Association, 2003.

### 3. Computable General Equilibrium Model and Data

#### 3.1. Computable General Equilibrium Model

The PROVIDE standard computable general equilibrium (CGE) model<sup>2</sup> is a member of the class of single country computable general equilibrium (CGE) models that are descendants of the approach to CGE modeling described by Dervis *et al.*, (1982). More specifically, the implementation of this model, using the GAMS (General Algebraic Modeling System) software, is a direct descendant and development of models devised in the late 1980s and early 1990s, particularly those models reported by Robinson *et al.*, (1990), Kilkenny (1991) and Devarajan *et al.*, (1994). The model is a SAM based CGE model, wherein the SAM serves to identify the agents in the economy and provides the database with which the model

<sup>2</sup> The PROVIDE standard computable general equilibrium (CGE) model used for this study is fully documented in PROVIDE TP2003:3; the description given below is a standard brief overview of the model's structure and principles.

is calibrated. The SAM also serves an important organisational role since the groups of agents identified by the SAM structure are also used to define sub-matrices of the SAM for which behavioural relationships need to be defined. As such the modeling approach has been influenced by Pyatt's 'SAM Approach to Modeling' (Pyatt, 1989).

The description of the model proceeds in three stages. The first stage is the identification of the behavioural relationships; these are defined by reference to the sub matrices of the SAM within which the associated transactions are recorded. The second stage is definitional, and involves the identification of the components of the transactions recorded in the SAM, while giving more substance to the behavioural relationships, especially with those governing inter-institutional transactions, and in the process defining the notation. The third stage uses a pair of figures to explain the nature of the price and quantity systems for commodity and activity accounts that are embodied within the model. The discussion of the default and optional closure rules available within the model are discussed in Section 4.

### 3.1.1. *Behavioural Relationships*

While the accounts of the SAM determine the agents that can be included within the model, and the transactions recorded in the SAM identify the transactions that took place, the model is defined by the behavioural relationships. The behavioural relationships in this model are a mix of non-linear and linear relationships that govern how the model's agents will respond to exogenously determined changes in the model's parameters and/or variables. Table 1 summarises these behavioural relationships by reference to the sub matrices of the SAM.

Households are assumed to choose the bundles of commodities they consume so as to maximise utility where the utility function is a Stone-Geary function that allows for subsistence consumption expenditures, which is an arguably realistic assumption when there are substantial numbers of very poor consumers. The households choose their consumption bundles from a set of 'composite' commodities that are aggregates of domestically produced and imported commodities. These 'composite' commodities are formed as Constant Elasticity of Substitution (CES) aggregates that embody the presumption that domestically produced and imported commodities are imperfect substitutes. The optimal ratios of imported and domestic commodities are determined by the relative prices of the imported and domestic commodities. This is the so-called Armington assumption (Armington, 1969), which allows for product differentiation via the assumption of imperfect substitution (see Devarajan *et al.*, 1994). The assumption has the advantage of rendering the model practical by avoiding the extreme specialisation and price fluctuations associated with other trade assumptions. In this model the country is assumed to be a price taker for all imported commodities.

Domestic production uses a two-stage production process. In the first stage aggregate intermediate and aggregate primary inputs are combined using Leontief technology. Hence intermediate input demands are in fixed proportions relative to the output of each activity, and the residual prices per unit of output after paying for intermediate inputs, the so-called value added price, are the amounts available for the payment of primary inputs. Primary inputs are combined to form aggregate value added using CES technologies, with the optimal ratios of primary inputs being determined by relative factor prices. The activities are defined as multi-product activities with the assumption that the proportionate combinations of commodity outputs produced by each activity/industry remain constant; hence for any given vector of commodities demanded there is a unique vector of activity outputs that must be produced. The vector of commodities demanded is determined by the domestic demand for domestically produced commodities and export demand for domestically produced commodities. Using the assumption of imperfect transformation between domestic demand and export demand, in the form of a Constant Elasticity of Transformation (CET) function, the optimal distribution of domestically produced commodities between the domestic and export markets is determined by the relative prices on the alternative markets. The model can be specified as a small country, i.e., price taker, on all export markets, or selected export commodities can be deemed to face downward sloping export demand functions, i.e., a large country assumption. The other behavioural relationships in the model are generally linear.

A few features do however justify mention. First, all the tax rates are declared as parameters with associated scaling factors that are declared as variables. If a fiscal policy constraint is imposed then one or more of the sets of tax rates can be allowed to vary equiproportionately to define a new vector of tax rates that is consistent with the fiscal constraint. Relative tax rates can be adjusted by resetting the tax rate parameters. Similar scaling factors are available for a number of key parameters, e.g., household savings rates and inter-institutional transfers. Second, technology changes can be introduced through changes in the activity specific efficiency parameters. Third, the proportions of current expenditure on commodities defined to constitute subsistence consumption can be varied. Fourth, although a substantial proportion of the sub matrices relating to transfers, especially with the rest of the world, contain zero entries, the model allows changes in such transfers, e.g., aid transfers to the government from the rest of the world are defined equal to zero in the database but they can be made positive, or even negative, for model simulations. And fifth, the model is set up with a range of flexible closure rules. The specific choices about closure rules used in this study are defined in the Policy Analysis section below.

**Table 1: Behavioural Relationships for the Standard Model**

	Commodities	Activities	Factors	Households	Enterprises	Government	Capital	RoW	Total	Prices
<b>Commodities</b>	0	Leontief Input-Output Coefficients	0	Utility Functions (CD or Stone-Geary)	Fixed in Real Terms	Fixed in Real Terms and Export Taxes	Fixed Shares of Savings	Commodity Exports	Commodity Demand	Consumer Commodity Price Prices for Exports
<b>Activities</b>	Domestic Production	0	0	0	0	0	0	0	Constant Elasticity of Substitution Production Functions	
<b>Factors</b>	0	Factor Demands (CD or CES)	0	0	0	0	0	Factor Income from RoW	Factor Income	
<b>Households</b>	0	0	Fixed Shares of Factor Income	Fixed (Real) Transfers	Fixed (Real) Transfers	Fixed (Real) Transfers	0	Remittances	Household Income	
<b>Enterprises</b>	0	0	Fixed Shares of Factor Income	0	0	Fixed (Real) Transfers	0	Transfers	Enterprise Income	
<b>Government</b>	Tariff Revenue	Indirect Taxes on Activities	Fixed Shares of Factor Income	Direct Taxes on Household Income	Direct Taxes on Enterprise Income	0	0	Transfers	Government Income	
<b>Capital</b>	0	0	Depreciation	Household Savings	Enterprise Savings	Government Savings (Residual)	0	Current Account 'Deficit'	Total Savings	
<b>Rest of World</b>	Commodity Imports	0	Fixed Shares of Factor Income	0	0	0	0	0	Total 'Expenditure' Abroad	
<b>Total</b>	Commodity Supply	Activity Input	Factor Expenditure	Household Expenditure	Enterprise Expenditure	Government Expenditure	Total Investment	Total 'Income' from Abroad		
	Producer Commodity Prices Domestic and World Prices for Imports	Value Added Prices								

### 3.1.2. Transaction Relationships

The transactions relationships are laid out in Table 2, which is in two parts. The prices of domestically consumed (composite) commodities are defined as  $PQD_c$ , and they are the same irrespective of which agent purchases the commodity. The quantities of commodities demanded domestically are divided between intermediate demand,  $QINTD_c$ , and final demand, with final demand further subdivided between demands by households,  $QCD_c$ , enterprises,  $QENTD_c$ , government,  $QGD_c$ , investment,  $QINVD_c$ , and stock changes,  $dstocconst_c$ . The value of total domestic demand, at purchaser prices, is therefore  $PQD_c * QQ_c$ . Consequently the decision to represent export demand,  $QE_c$ , as an entry in the commodity row is slightly misleading, since the domestic prices of exported commodities,  $PE_c = PWE_c * ER$ , do not accord with the law of one price. The representation is a space saving device that removes the need to include separate rows and columns for domestic and exported commodities. The price wedges between domestic and exported commodities are represented by export duties,  $te_c$ , that are entered into the commodity columns. Commodity supplies come from domestic producers who receive the common prices,  $PXC_c$ , for outputs irrespective of which activity produces the commodity, with the total domestic production of commodities being denoted as  $QXC_c$ . Commodity imports,  $QM_c$ , are valued carriage insurance and freight (cif) paid, such that the domestic price of imports,  $PM_c$ , is defined as the world price,  $PWM_c$ , times the exchange rate,  $ER$ , plus an *ad valorem* adjustment for import duties,  $tm_c$ . All domestically consumed commodities are subject to a sales tax,  $ts_c$ .

Domestic production activities receive average prices for their output,  $PX_a$ , that are determined by the commodity composition of their outputs. Since activities produce multiple outputs their outputs can be represented as an index,  $QX_a$ , formed from the commodity composition of their outputs. In addition to intermediate inputs, activities also purchase primary inputs,  $FD_{f,a}$ , for which they pay average prices,  $WF_f$ . To create greater flexibility the model allows the price of each factor to vary according to the activity that employs the factor. Finally each activity pays production taxes, the rates,  $tx_a$ , for which are proportionate to the value of activity outputs.

The model allows for the domestic use of both domestic and foreign owned factors of production, and for payments by foreign activities for the use of domestically owned factors. Factor incomes therefore accrue from payments by domestic activities and foreign activities,  $factwor_f$ , where payments by foreign activities are assumed exogenously determined and are denominated in foreign currencies. After allowing for depreciation,  $deprec_f$ , and the payment of factor taxes,  $tf_f$ , the residual factor incomes,  $YFDIST_f$ , are divided between domestic institutions (households, enterprises and government) and the rest of the world in fixed proportions.

Households receive incomes from factor rentals and/or sales, inter household transfers,  $hohoconst_{h,h}$ , transfers from enterprises,  $hoentconst_h$ , and government,  $hogovconst_h$ , and remittances from the rest of the world,  $howor_h$ , where remittances are defined in terms of the foreign currency. Household expenditures consist of payments of direct/income taxes,  $ty_h$ , after which savings are deducted, where the savings rates,  $caphosh_h$ , are fixed exogenously in the base model. The residual household income is then divided between inter household transfers and consumption expenditures, with the pattern of consumption expenditures determined by the household utility functions.

The enterprise account receives income from factor sales, primarily in the form of retained profits,<sup>3</sup> transfers from government,  $entgovconst$ , and foreign currency denominated transfers from the rest of the world,  $entwor$ . Expenditures then consist of the payment of direct/income taxes,  $tye$ , consumption, which is assumed fixed in real terms,<sup>4</sup> and savings, which are defined as a residual, i.e., the difference between income,  $YE$ , and committed expenditure,  $EENT$ . There is an analogous treatment of government savings, i.e., the internal balance, which is defined as the difference (residual) between government income,  $YG$ , and committed government expenditure,  $EG$ . In the absence of a clearly definable set of behavioural relationships for the determination of government consumption expenditure, the quantities of commodities consumed by the government are fixed in real terms, and hence government consumption expenditure will vary with commodity prices.<sup>5</sup> Transfers by the government to other domestic institutions are fixed in nominal terms, although there is a facility to allow them to vary, e.g., with consumer prices. On the other hand government incomes can vary widely. Incomes accrue from the various tax instruments (import and export duties, sales, production and factor taxes, and direct taxes), that can all vary due to changes in the values of production, trade and consumption. The government also receives foreign currency denominated transfers from the rest of the world,  $govwor$ , e.g., aid transfers.

---

<sup>3</sup> Hence the model contains the implicit presumption that the proportions of profits retained by incorporated enterprises are constant.

<sup>4</sup> Hence consumption expenditure is defined as the fixed volume of consumption,  $QENTD_c$ , times the variable prices. It requires only a simple adjustment to the closure rules to fix consumption expenditures. Without a utility function, or equivalent, for enterprises it is not possible to define the quantities consumed as the result of an optimisation problem.

<sup>5</sup> The closure rules allow for the fixing of government consumption expenditure rather than real consumption.

**Table 2: Transactions Relationships for the Standard Model**

	Commodities	Activities	Factors	Households
<b>Commodities</b>	0	$(PQD_c * QINTD_c)$	0	$(PQD_c * QCD_c)$
<b>Activities</b>	$(PXC_c * QXC_c)$ $(PX_a * QX_a)$	0	0	0
<b>Factors</b>	0	$(WF_f * FD_{f,a})$	0	0
<b>Households</b>	0	0	$\sum_f hovash_{h,f} * YFDISP_f$	$(\sum_{hh} hohoconst_{hh,h})$
<b>Enterprises</b>	0	0	$\left( \sum_f entvash_f * YFDISP_f \right)$	0
<b>Government</b>	$(tm_c * PWM_c * QM_c * ER)$ $(te_c * PWE_c * QE_c * ER)$ $(ts_c * PQS_c * QQ_c)$	$(tx_a * PX_a * QX_a)$	$\left( \sum_f govvash_f * YFDISP_f \right)$ $(tf_f * YFDISP_f)$	$(ty_h * YH_h)$
<b>Capital</b>	0	0	$\sum_f deprec_f$	$(caphosh_n * YH_h)$
<b>Rest of World</b>	$(PWM_c * QM_c * ER)$	0	$\left( \sum_f worvash_f * YFDISP_f \right)$	0
<b>Total</b>	$(PQD_c * QQ_c)$	$(PX_a * QX_a)$	$YF_f$	$YH_h$

**Table 2b Transactions Relationships for the Standard Model**

	Enterprises	Government	Capital	RoW	Total
<b>Commodities</b>	$(PQD_c * QENTD_c)$	$(PQD_c * QGD_c)$	$(PQD_c * QINVD_c)$ $(PQD_c * dstocconst_c)$	$(PWE_c * QE_c * ER)$	$(PQD_c * QQ_c)$
<b>Activities</b>	0	0	0	0	$(PX_a * QX_a)$
<b>Factors</b>	0	0	0	$(factwor_f * ER)$	$YF_f$
<b>Households</b>	$hoentconst_h$	$(hogovconst_h * HGADJ)$	0	$(howor_h * ER)$	$YH_h$
<b>Enterprises</b>	0	$(entgovconst * EGADJ)$	0	$(entwor * ER)$	$EENT$
<b>Government</b>	$(TYEADJ * tye * YE)$	0	0	$(govwor * ER)$	$EG$
<b>Capital</b>	$(YE - EENT)$	$(YG - EG)$	0	$(CAPWOR * ER)$	$TOTSAV$
<b>Rest of World</b>	0	0	0	0	Total 'Expenditure' Abroad
<b>Total</b>	$YE$	$YG$	$INVEST$	Total 'Income' from Abroad	

Domestic investment demand consists of fixed capital formation,  $QINVD_c$ , and stock changes,  $dstocconst_c$ . The comparative static nature of the model and the absence of a capital composition matrix underpin the assumption that the commodity composition of fixed capital formation is fixed, while a lack of information means that stock changes are assumed invariant. However the value of fixed capital formation will vary with commodity prices while the volume of fixed capital formation can vary both as a consequence of the volume of savings changing or changes in exogenously determined parameters. In the base version of the model domestic savings are made up of savings by households, enterprises, the government (internal balance) and foreign savings, i.e., the balance on the capital account or external balance,  $CAPWOR$ . The various closure rules available within the model allow for different assumptions about the determination of domestic savings, e.g., flexible versus fixed savings rates for households, and value of ‘foreign’ savings, e.g., a flexible or fixed exchange rate.

Incomes to the rest of the world account, i.e., expenditures by the domestic economy in the rest of the world, consist of the values of imported commodities and factor services. On the other hand expenditures by the rest of the world account, i.e., incomes to the domestic economy from the rest of the world, consist of the values of exported commodities and NET transfers by institutional accounts. All these transactions are subject to transformation by the exchange rate. In the base model the balance on the capital account is fixed at some target value, denominated in foreign currency terms, e.g., at a level deemed equal and opposite to a sustainable deficit on the current account, and the exchange rate is variable. This assumption can be reversed, where appropriate, in the model closure.

### 3.1.3. Price and quantity systems

Figures 4 and 5 provide an overview of the interrelationships between the prices and quantities. The supply prices of the composite commodities ( $PQS_c$ ) are defined as the weighted averages of the domestically produced commodities that are consumed domestically ( $PD_c$ ) and the domestic prices of imported commodities ( $PM_c$ ), which are defined as the products of the world prices of commodities ( $PWM_c$ ) and the exchange rate ( $ER$ ) uplifted by *ad valorem* import duties ( $tm_c$ ). These weights are updated in the model through first order conditions for optima. The supply prices exclude sales taxes, and hence must be uplifted by (*ad valorem*) sales taxes ( $ts_c$ ) to reflect the composite consumer price ( $PQD_c$ ). The producer prices of commodities ( $PXC_c$ ) are similarly defined as the weighted averages of the prices received for domestically produced commodities sold on domestic and export ( $PE_c$ ) markets; the weights are updated in the model through first order conditions for optima. The prices received on the export market are defined as the products of the world price of exports ( $PWE_c$ ) and the exchange rate ( $ER$ ) less any exports duties due, which are defined by *ad valorem* export duty rates ( $te_c$ ).

The average price per unit of output received by an activity ( $PX_a$ ) is defined as the weighted average of the domestic producer prices, where the weights are constant. After paying indirect/production/output taxes ( $tx_a$ ), this is divided between payments to aggregate value added ( $PVA_a$ ), i.e., the amount available to pay primary inputs, and aggregate intermediate inputs ( $PINT_a$ ). Total payments for intermediate inputs per unit of aggregate intermediate input are defined as the weighted sums of the prices of the inputs ( $PQD_c$ ).

**Figure 4: Price Relationships for a Standard Model**

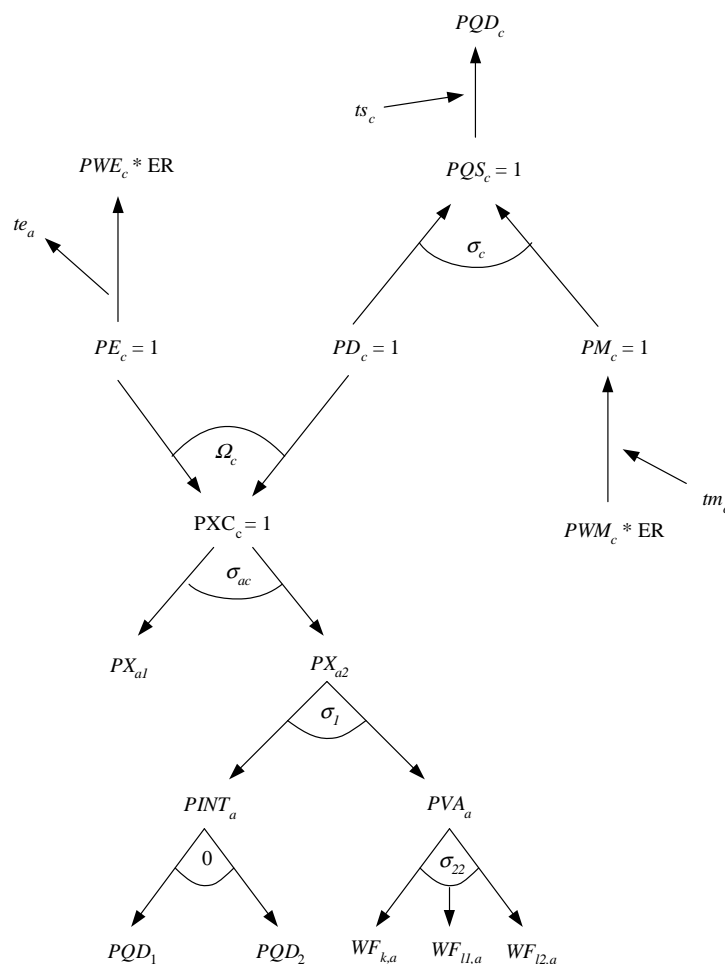

Total demands for the composite commodities,  $QQ_c$ , consist of demands for intermediate inputs,  $QINTD_c$ , consumption by households,  $QCD_c$ , enterprises,  $QENTD_c$ , and government,  $QGD_c$ , gross fixed capital formation,  $QINVD_c$ , and stock changes,  $dstocconst_c$ . Supplies from domestic producers,  $QD_c$ , plus imports,  $QM_c$ , meet these demands; equilibrium conditions ensure that the total supplies and demands for all composite commodities equate. Commodities are delivered to both the domestic and export,  $QE_c$ , markets subject to equilibrium conditions that require all domestic commodity production,  $QXC_c$ , to be either domestically consumed or exported.

Figure 5: Quantity Relationships for a Standard Model

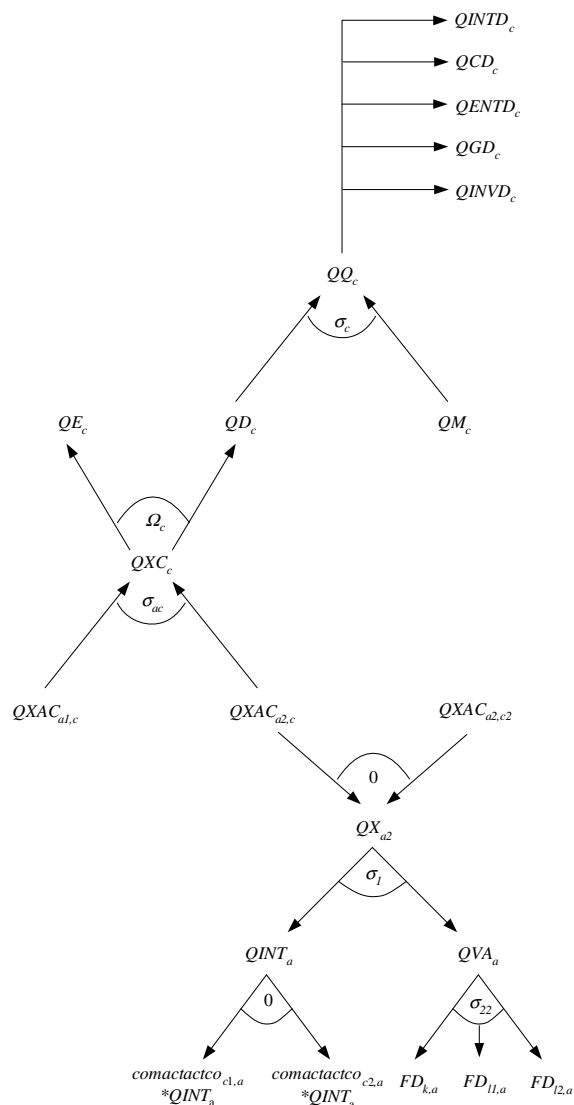

The presence of multiple product activities means that domestically produced commodities can come from multiple activities, i.e., the total production of a commodity is defined as the sum of the amount of that commodity produced by each activity. Hence the domestic production of a commodity ( $QXC_c$ ) is a CES aggregate of the quantities of that commodity produced by a number of different activities ( $QXAC_{a,c}$ ), which are produced by each activity in activity specific fixed proportions, i.e., the output of  $QXAC_{a,c}$  is a Leontief (fixed proportions) aggregate of the output of each activity ( $QX_a$ ).

Production relationships by activities are defined by a series of nested Constant Elasticity of Substitution (CES) production functions. The nesting structure is illustrated in the lower part of Figure 5, where, for illustration purposes only, two intermediate inputs and three

primary inputs ( $FD_{k,a}$ ,  $FD_{l1,a}$  and  $FD_{l2,a}$ ) are identified. Activity output is a CES aggregate of the quantities of aggregate intermediate inputs ( $QINT_a$ ) and value added ( $QVA_a$ ), while aggregate intermediate inputs are a Leontief aggregate of the (individual) intermediate inputs and aggregate value added is a CES aggregate of the quantities of primary inputs demanded by each activity ( $FD_{f,a}$ ). The allocation of the finite supplies of factors ( $FS_f$ ) between competing activities depends upon relative factor prices via first order conditions for optima. While the base model contains the assumption that all factors are fully employed and mobile this assumption can be, and often is, relaxed.

### 3.2. The Data

The data used for this study are arranged in three groups; a SAM that records all transactions between agents in the economy, a factor use matrix that identifies the quantities of each different factor used by each activity in the period to which the SAM refers, and series of elasticities that control the operation of the model's behavioural functions.

The SAM is a 118 account aggregation of the PROVIDE SAM for South Africa in 2000 (see PROVIDE TP2004:1 for a full description of the South Africa SAM database). The model SAM has 39 commodity groups (11 and 10 for agricultural and food commodities respectively), 37 activity groups (9 and 10 for agricultural and food activities), 14 factor groups – 12 types of labour plus land and capital, 14 household groups – distinguished by residential location, income level and racial group, and miscellaneous enterprise, government, capital (savings and investment) and rest of the world accounts. A full list of the SAM accounts is provided as Appendix Table 4.

A feature of the SAM that justifies emphasis here is the treatment of activities and specifically agricultural activities. The SAM uses a supply and use structure<sup>6</sup> that allows for the possibility that all activities can produce multiple products, which is the case for all activities in this SAM. Agricultural activities are defined by reference to regions of the country; ideally this would be by agronomic region but the agricultural census data are by magisterial district. This classification of agricultural activities has, *inter alia*, a number of implications: each agricultural activity can produce a range of commodities; land is specific to each agricultural activity and cannot be transferred to another use; and the profitability of farming for all agricultural activities depends upon the effects of policy shock across a range of commodity (output) prices.

---

<sup>6</sup> By definition each activity in an input-output structure (as opposed to a supply and use structure) produce a single commodity and each commodity is produced by a single activity.

## 4. Policy Analysis

### 4.1. Policy Scenarios

The policy scenarios examined in this study are analyses of the South African sugar industry in the context of increased liberalisation of the international sugar market; the scenarios are relatively straightforward and derive from the discussion above. Any substantive liberalisation of global sugar trade, particularly if it was accompanied by sustained reductions in the levels of domestic support in the EU and USA, would be expected to result in an increase in the world price (export and import) of sugar and sugar products as the proportion of sugar traded on a 'free' market increases (Mitchell, 2004). However increased liberalisation of global sugar trade is likely to increase the degree of competition and hence provide a strong incentive for the South African sugar industry to increase its efficiency. Hence there three sets of experiments

- sugar trade liberalisation that manifests as increases of up to 50 percent in the export price of South African sugar;<sup>7</sup>
- improvements of up to 10 percent in the efficiency with which cane is transformed into raw sugar (effectively a reduction in the TCTS ratio); and
- a combination of increases of up to 50 percent in the world price of sugar and improvements of up to 10 percent in the efficiency of transforming cane into raw sugar.

All the policy experiments are run twice; in the first cycle it is assumed that South Africa is a price taker of the newly liberalised global sugar market while in the second cycle it is assumed that South Africa is a sufficiently large producer and exporter of sugar to cause the world price to decline as it increases exports.

### 4.2. Model Closure Rules

The model closure rules were selected with the objective of providing a realistic representation of the South African economy and can be categorised under six headings.

#### 4.2.1. *Foreign Exchange Market Closure*

The foreign exchange market is assumed to clear via a flexible exchange rate and therefore the external balance – surplus/deficit on the current account – is assumed to be fixed. For all imports South Africa is assumed to be a price taker on global markets; hence it can import any quantity of a particular good or service at a constant price (in terms of foreign currency units).

---

<sup>7</sup> Mitchell (2004) reports estimates of up to 40 percent increase in world sugar prices as a result of global (multilateral) liberalisation.

But on the export markets South Africa is assumed to have some power over the world price of gold; hence it is assumed that South Africa faces a downward sloping export demand curve for gold, with a constant price elasticity of demand of  $-0.5$  – the more gold South Africa exports the lower the price it receives per unit of gold exported.

South Africa is also assumed to face a downward sloping export demand curve for sugar exports, with a constant price elasticity of demand of  $-0.2$ . However unlike the other closure rules for the foreign exchange market this closure rule is relaxed in one sequence of the simulations.

#### 4.2.2. *Investment-Savings Closure*

The capital account – investment and savings – is closed by assuming that the share of domestic absorption accounted for by investment, in terms of expenditure, remains constant. This allows for some variation in the volume of investment from both changes in the prices of investment goods and from any change in the total value of domestic absorption. The equilibrating variable is therefore a change in the savings rate; in this case the savings rates of all households and incorporated business enterprises are allowed to vary equiproportionately.

#### 4.2.3. *Government Closure Rules*

The government account is closed by variations in the level of government borrowing/savings. All tax rates are assumed to remain constant and the government is assumed to consume a fixed share of domestic absorption. The impacts of the policy shocks upon government revenue are small and hence the impact upon government borrowing is small; consequently the impact of allowing the government savings to vary is marginal.

#### 4.2.4. *Factor Market Closure*

The factor market closure involves different treatments for different factors. The land factor is assumed to be activity specific and the demand is fixed; this reflects the fact that the agricultural activities are defined by specific locations and hence cannot change the amount of land available. The labour categories are subdivided into three broad groups – skilled, unskilled and manual (see Table 3). Skilled labour is assumed to be fully employed and mobile across economic activities and hence the equilibrating variable is the wage rate. The supply of unskilled and manual labour is assumed to be perfectly elastic hence activities can consume as much labour as they want at a constant wage rate. The equilibrating variable is the quantity of unskilled labour employed. For physical capital two alternative scenarios are explored; a short run scenario where the quantity of capital used by each activity is fixed, and a long run scenario where the total quantity of capital is fixed but it is mobile across activities.

**Table 3: Fully Employed and Unemployed Labour Categories**

<b>Fully Employed Labour</b>	<b>Unemployed Labour</b>
African skilled labour	African unskilled labour
Coloured skilled labour	African manual labour
Asian skilled labour	Coloured unskilled labour
Asian unskilled labour	Coloured manual labour
Asian manual labour	
White skilled labour	
White unskilled labour	
White manual labour	

#### 4.2.5. *Model Numéraire*

The model numéraire is the consumer price index; hence all the value results are in real terms.

#### 4.3. Results and Analyses

Despite the agricultural sector accounting for a relatively small share of GDP, some 4 percent, and the sugar industry being a relatively small part of the agricultural sector, the liberalisation of the sugar trade has a noticeable impact upon GDP (see Figure 6). In the small country case and without technical change in sugar processing, GDP (GDP\_sc) increases by up to 0.03 percent, this is more than doubled (0.078 percent) when there is technical change (GDP\_sc\_tc). The increase in exports associated with liberalisation (see below) causes the exchange rate to appreciate by 0.085 percent without technical change (ER\_sc),<sup>8</sup> but with technical change (ER\_sc\_tc) it depreciates unless the change in the world price of sugar exceeds about 42 percent (the reasons behind this are explored below).

---

<sup>8</sup> The exchange rate in the model is defined as the quantity of domestic currency required to purchase a unit of 'world' currency. Hence an appreciation of the exchange rate results in a reduction in the amount of domestic currency required to purchase a unit of world currency.

**Figure 6: GDP and the Exchange Rate – Small vv Large Country Assumption with 10 percent change in TCTS**

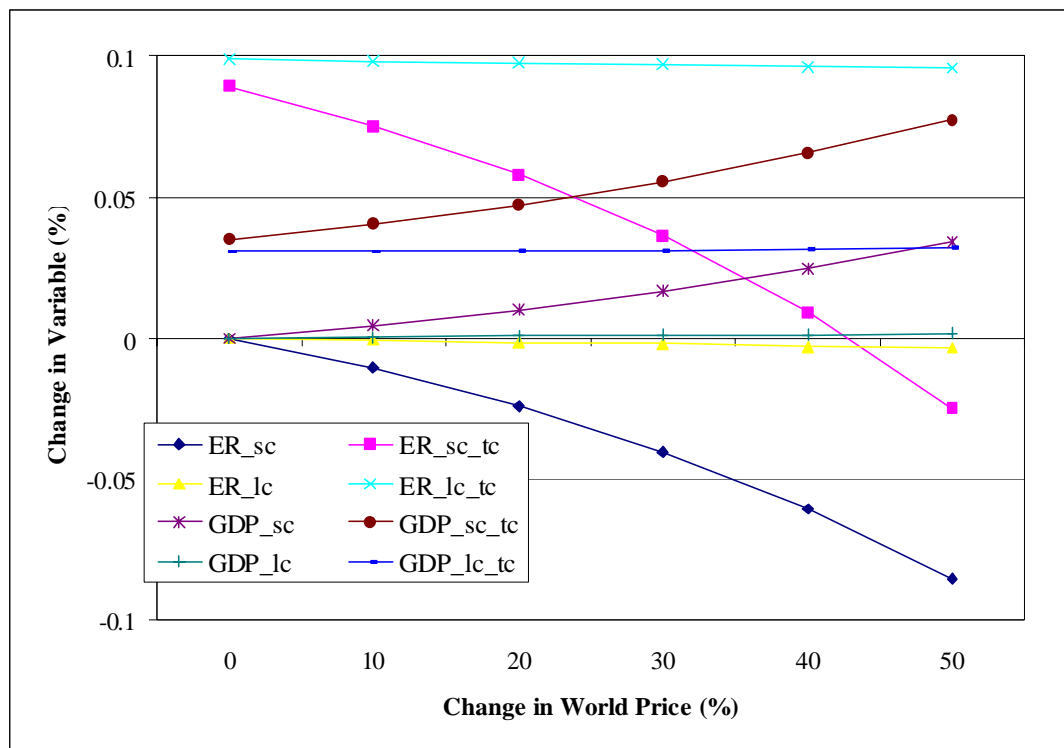

Source: Simulation results

The large country case produces a very different picture: without technical change in sugar processing the potential gains in GDP are cancelled out by the declining export price and hence the exchange rate is largely unchanged, whereas with technical change all the benefits, in terms of GDP, are realised from the technical change effects with which there is an associated depreciation of the exchange rate. Clearly there would have been increases in GDP if the price elasticity of demand for sugar exports had been larger, i.e., less negative. While this may be the case, the fundamental point remains unaffected: if increases in South African sugar exports exert any downward pressure on world prices some, and maybe all, of the potential benefits may be nullified.

**Figure 7: Price of Value Added (PVA) for Agriculture and Sugar Processing – Small Country Assumption without change in TCTS**

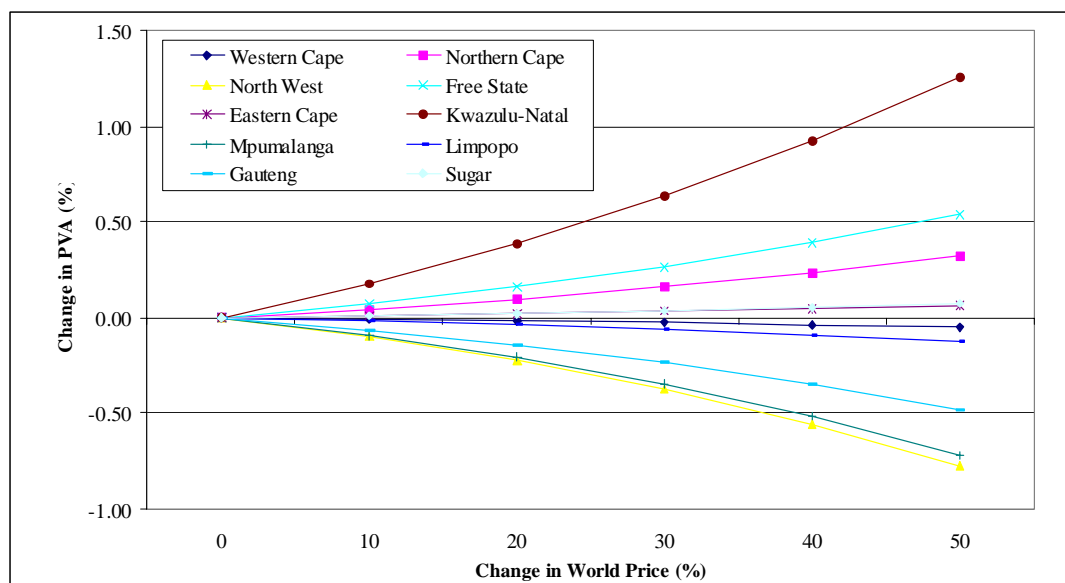

Source: Simulation results

Arguably of greater interest are the consequences of sugar trade liberalisation for agriculture in South Africa. *A priori* it might be reasonable to expect that agriculture in the provinces that produce sugar would benefit, while the implications for other provinces would be limited. These simulations indicate that the outcomes may be more complex. An important indicator of the implications for agriculture are the rates of return to aggregate primary inputs, i.e., the prices of value added, which indicate the extent to which activities seek to expand or contract as a result of the policy shock – these are reported for agriculture and the sugar processing industry in Figure 7 and 8. In the small country case without technical change, Figure 7, the impact upon agriculture in KwaZulu-Natal confirms with expectations, the price of value added rises by up to 1.25 percent, but in contrast it falls by up to 0.72 percent in Mpumalanga, which is the other province that produces substantial amounts of sugar. Moreover the prices of value added vary appreciably across agriculture in different provinces, with the Northern Cape (up to 0.32 percent), the Free State (up to 0.54 percent) and the Eastern Cape (up to 0.07 percent) also gaining but with the Western Cape (up to -0.05 percent), Limpopo (up to -0.13 percent), North West (up to -0.77 percent) and Gauteng (up to -0.48 percent) losing.

The generality of the results presented in Figure 7 are unaffected by the presence of technical change in sugar processing (see Figure 8). Technical change in sugar processing changes the starting point, with KwaZulu-Natal and the Free State (marginally) losing out if world prices remain unchanged and the other agricultural activities gaining. But as the world

price of sugar increases so the same patterns of responses in price of value added (PVA) assert themselves; such that the overall impact of the change in technology is to cause a shift upwards in the PVA curves and move the point of intersection to when the world price has increased by about 15 percent.

**Figure 8 Price of Value Added (PVA) for Agriculture and Sugar Processing – Small Country Assumption with 10 percent change in TCTS**

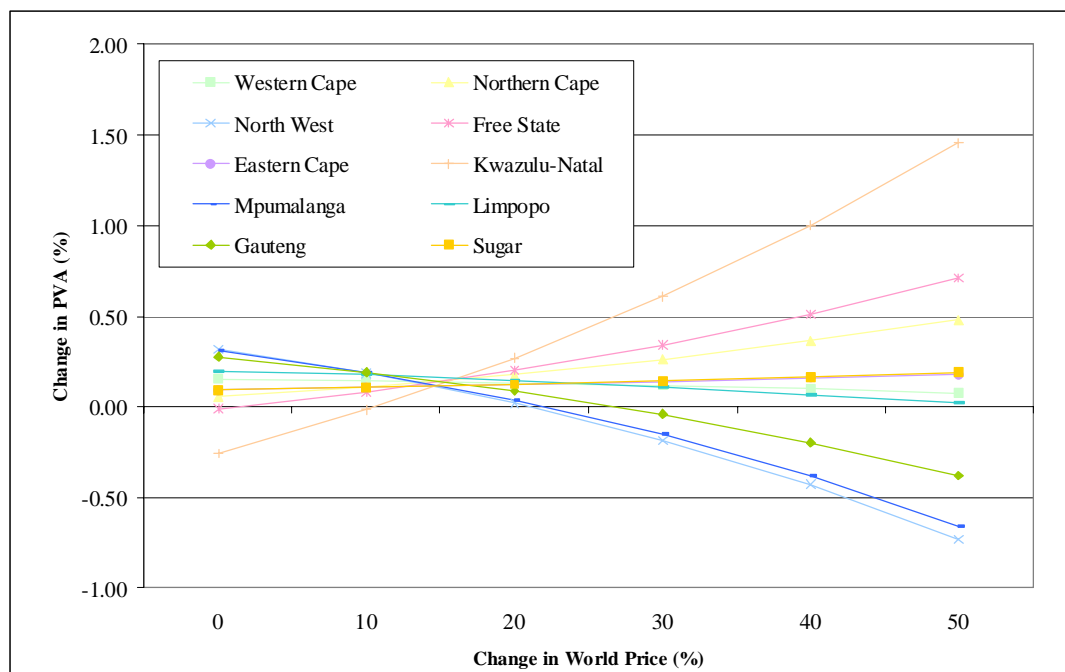

Source: Simulation results

The initially counterintuitive nature of these results is a consequence of the fact that the agricultural activities, defined by province of location, are multi product activities, i.e., they produce a range of agricultural commodities. The liberalisation of the sugar trade causes changes in the exchange rate, which means that the prices of all traded commodities are subject to change and therefore the prices received by domestic producers will change (see Figure 9 for the combined effects of a 30 percent change in export price and a 10 percent improvement in the TCTS ratio).<sup>9</sup> Apart from sugarcane all the changes are relatively small but in combination with differences in the output mix of the different agronomic regions they are sufficient to generate a range of different ‘average’ prices received by each province for their composite outputs (see Figure 10). As can be seen the signs on the changes in prices for

<sup>9</sup> It is worth noting that the technical change reduces the (derived) price of sugarcane, which is to be expected since relatively less is demanded as an input, but that the combined effects of the increased export price and technical change are appreciably greater than the sum of the component parts.

composite outputs by each agricultural activity explain the signs on the prices of value added – the results for the increase in export price correspond to the results in Figure 7, while the results for the change in export prices and technical change correspond to the results in Figure 8.

**Figure 9 Prices of Agricultural Commodities Sold on the Domestic Market– Small Country Assumption with and without 10 percent change in TCTS**

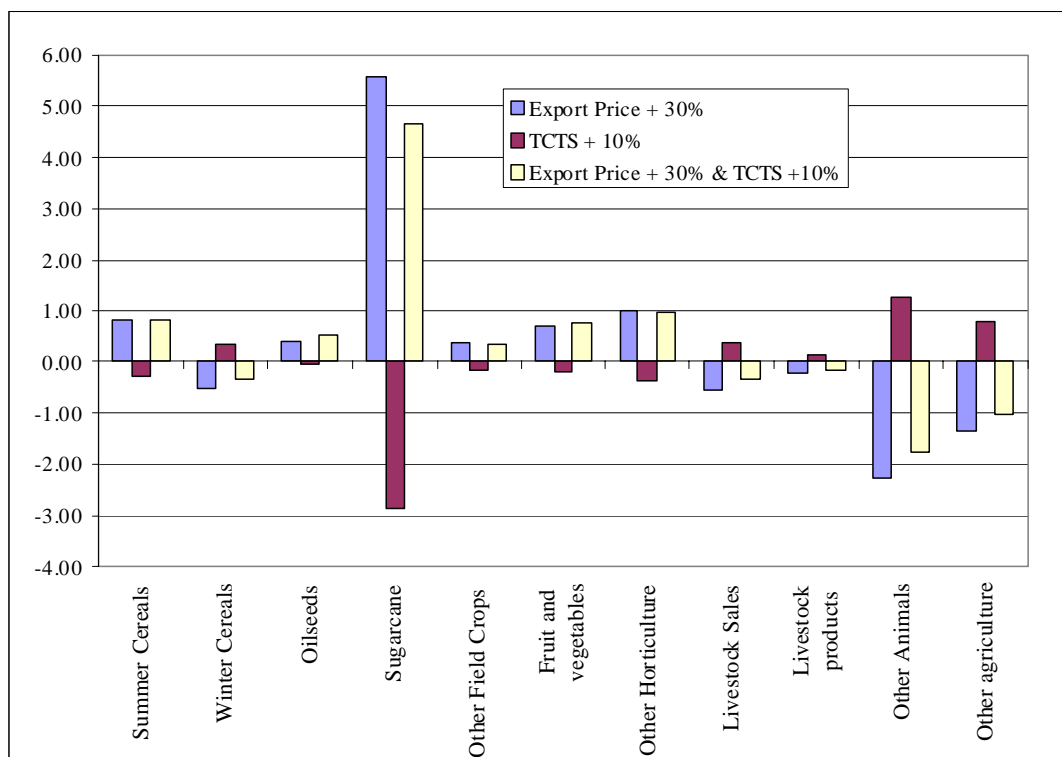

Source: Simulation results

Consequently it is the differences in output mix produced in each agronomic region, in combination with the prices changes driven initially by the changes in the exchange rate, and to a lesser extent the small income effect, that cause the effects of sugar trade liberalisation to have repercussions for South African agriculture beyond those areas that produce sugarcane. This is especially relevant in the of Mpumalanga, where the impact of technical change alone increases the activity price, which is the reverse of the case in KwaZulu-Natal while the trade liberalisation effect is to reduce the activity price, which again is the reverse of the case for KwaZulu-Natal. A further interesting effect is how technical change in the sugar industry increases the composite activity prices across all provinces, and that these price increases are sufficient in the case of the Western Cape and Limpopo (just) to cancel out the negative effect of the exchange rate.<sup>10</sup>

<sup>10</sup> There is also an income effect associated with the increase in GDP and welfare (see below) that will result in a minor expansion of agricultural activity.

**Figure 10: Activity Prices for Agricultural Activities – Small Country Assumption with and without 10 percent change in TCTS**

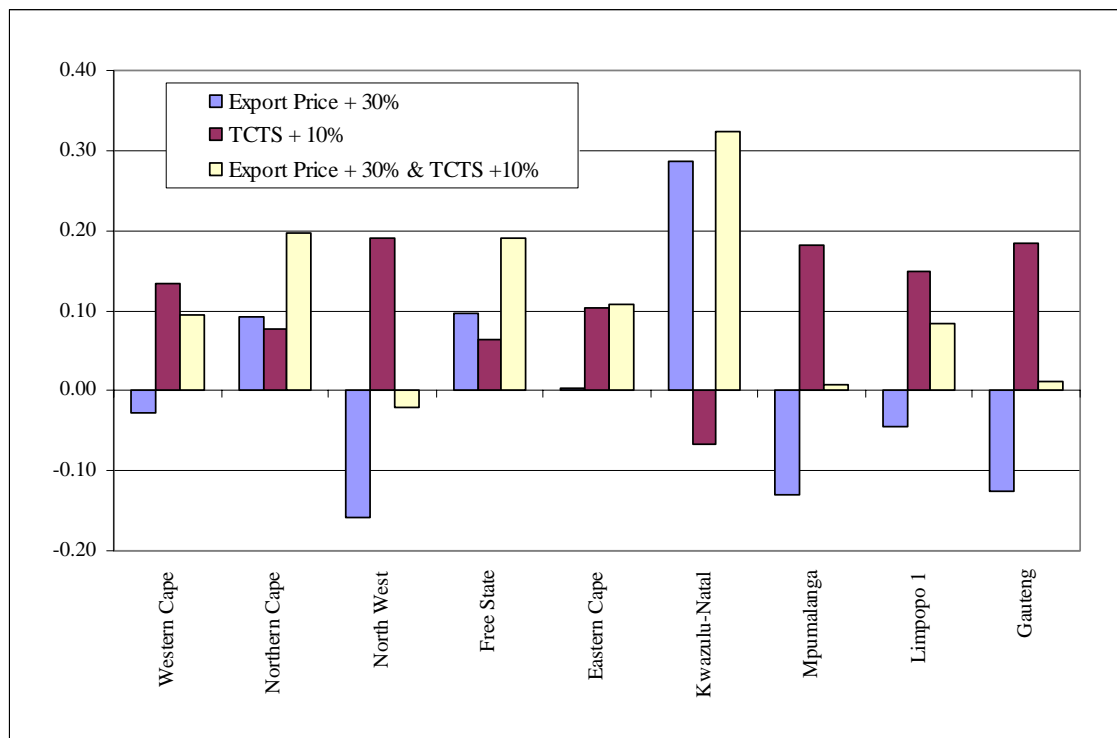

Source: Simulation results

These price changes stimulate substantial changes in factor demand by agriculture across the provinces. For the combined effects of a 30 percent change in export price and a 10 percent improvement in the TCTS ratio these range from plus 5.2 percent to minus 2.9 percent for African labour in KwaZulu-Natal and Limpopo respectively (Figure 11), from plus 1.9 percent to minus 0.4 percent for Coloured labour in the Free State and in the Western Cape (Figure 12) and from plus 4.8 percent to minus 2.9 percent for White labour in the KwaZulu-Natal and in the North West (Figure 13). Even allowing for the relatively small proportions of the South Africa workforce that are engaged in agriculture these changes in factor demands represent a substantial structural change that may take some time to be effected.

**Figure 11: Factor Demand by Agriculture for 30 percent Change in World price with and without 10 percent Change in TCTS– African Labour**

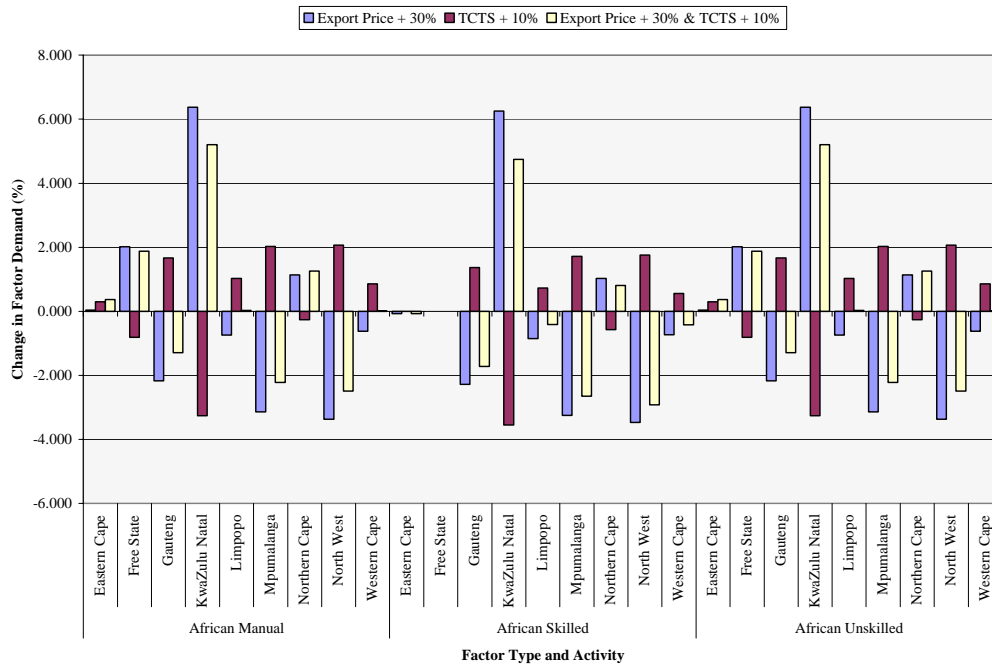

Source: Simulation results

**Figure 12: Factor Demand by Agriculture for 30 percent Change in World price with and without 10 percent Change in TCTS– Coloured Labour**

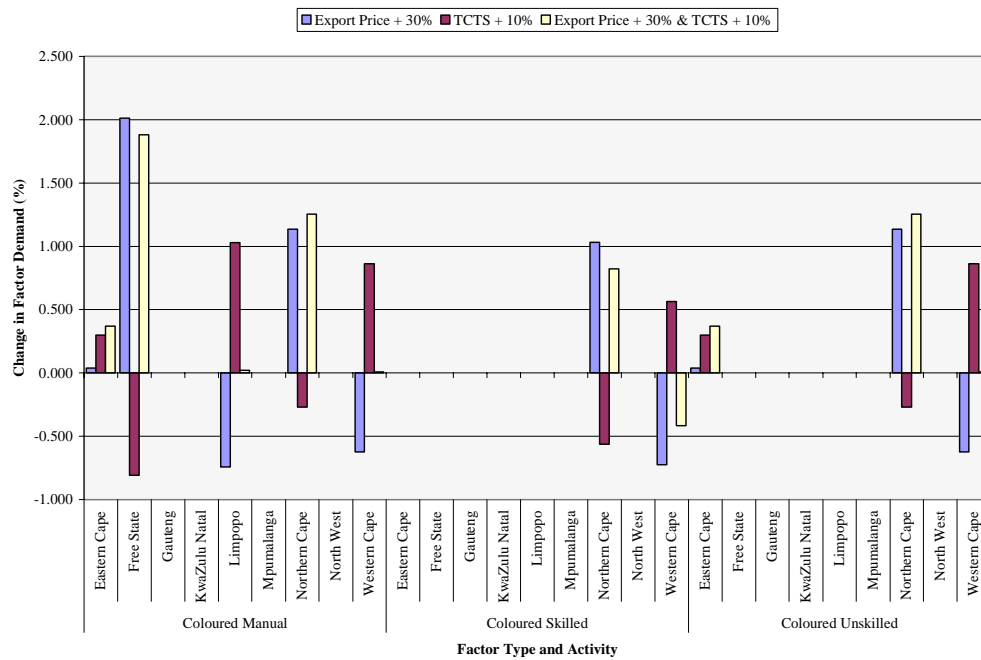

Source: Simulation results

**Figure 13: Factor Demand by Agriculture for 30 percent Change in World price with and without 10 percent Change in TCTS– White Labour**

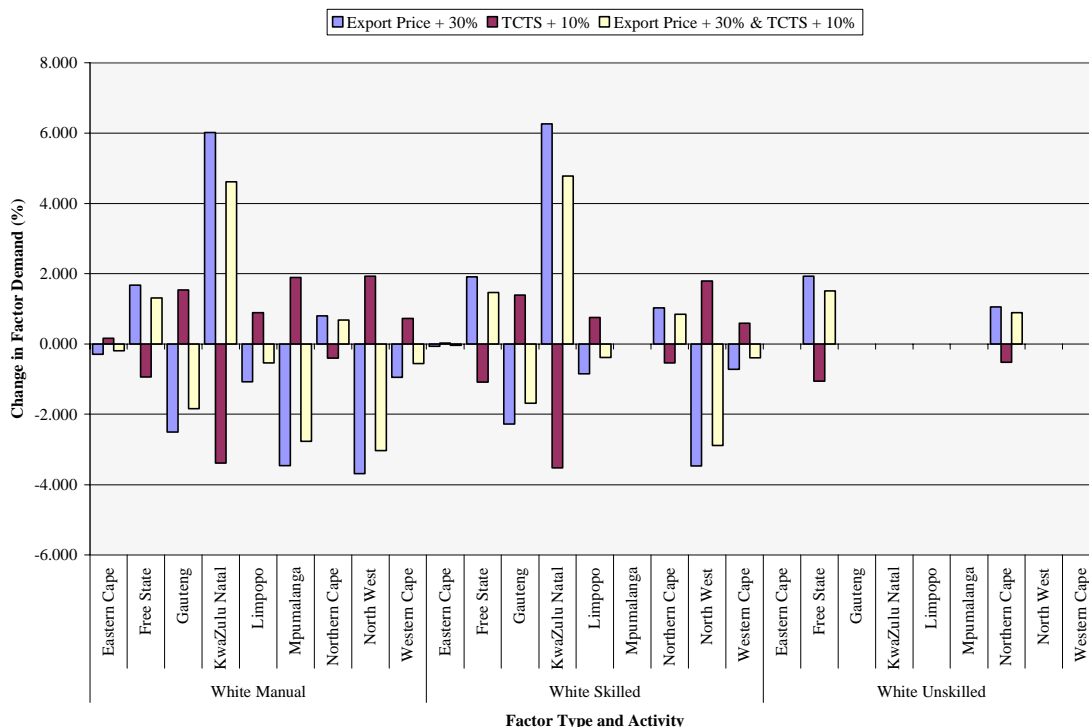

Source: Simulation results

If the new equilibria are achieved there are however across the board welfare gains for the (representative) households. Under the maintained small country assumption the total welfare gains (equivalent variation) are R311m, R792m and R1,186m for the 30 percent increase in the world price, the 10 percent increase in technical efficiency and the combination of the two effects respectively. The distribution of these gains shows some evidence of being biased towards the lower income households – see Figure 14 – since the gains are concentrated among African and Coloured households, but there are also substantial welfare gains for the Urban White Households who have appreciably higher incomes and are fewer in number. The across the board welfare gains are also found when there is a downward sloping export demand curve for sugar, although the total gains are substantially reduced (R18m, R711m and R728m for the 30 percent increase in the world price, the 10 percent increase in technical efficiency and the combination of the two effects respectively), the distribution of the gains is remarkably similar – see Figure 15.

**Figure 14: Household Welfare with Small Country Assumption**

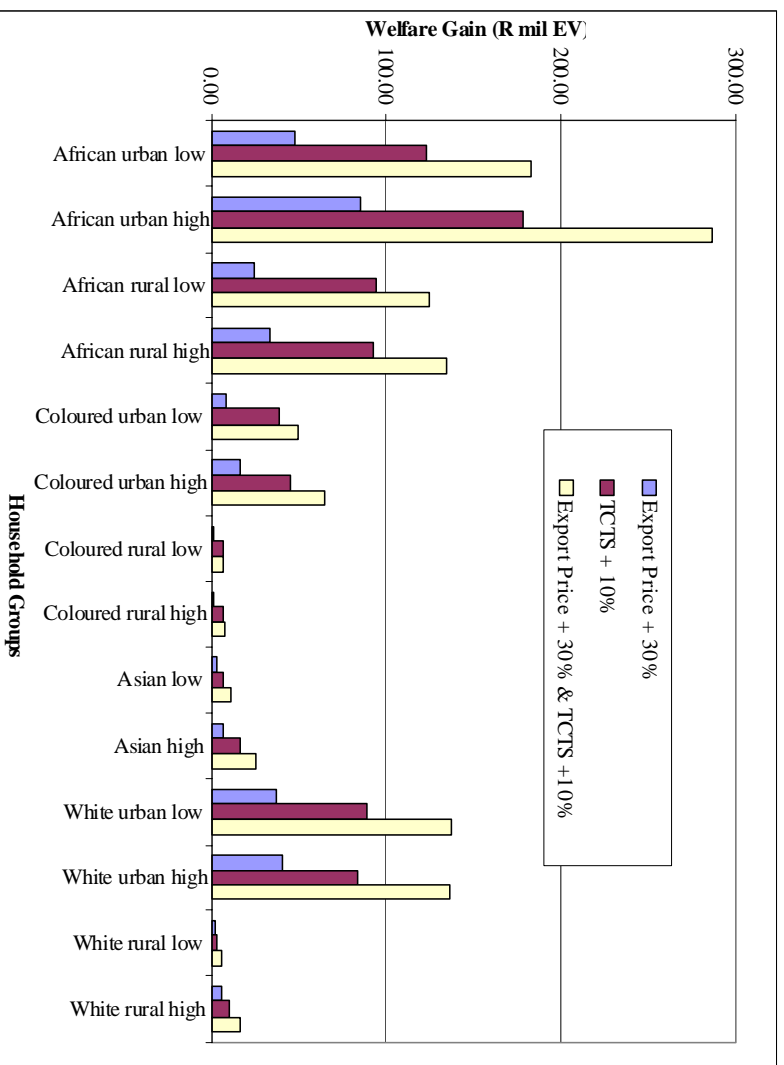

Source: Simulation results

**Figure 15: Household Welfare with Large Country Assumption**

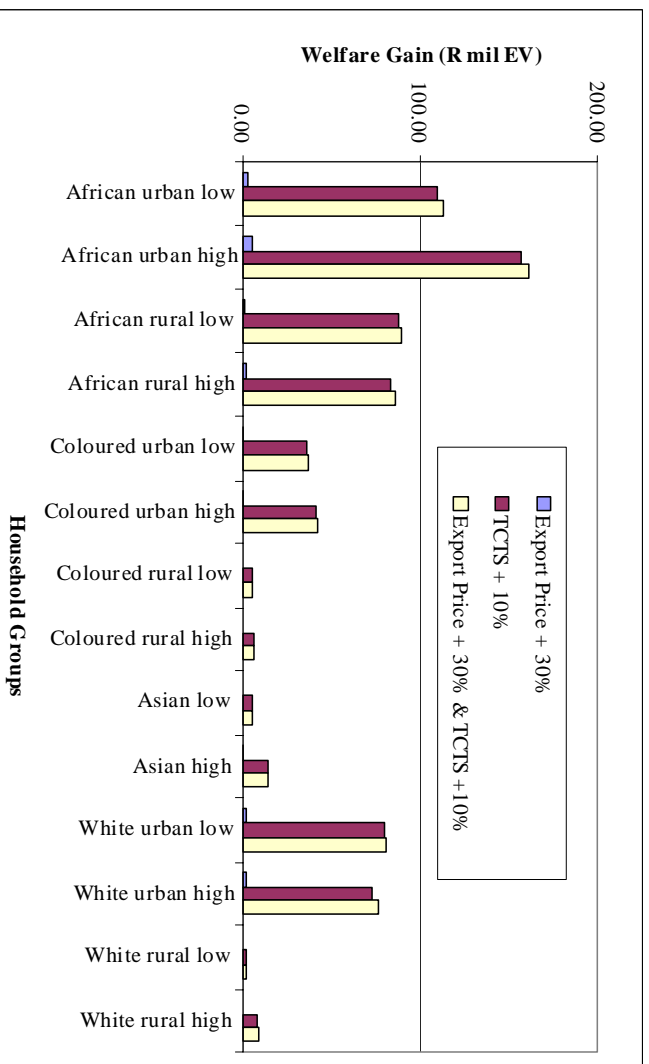

Source: Simulation results

An important feature of the welfare gains is the extent to which they demonstrate both the relative importance of and the complementarity of the trade liberalisation and technical efficiency gains. In the small country case the impacts of the efficiency gain on welfare are greater than the trade liberalisation effects for all households and the welfare effects of the combined simulations are greater than the sum of the two separate components. In the large country case the welfare effects of the trade liberalisation scenario are close to zero, which is not surprising, but the benefits from technical change are virtually unaffected.

These welfare effects are a combination of income and prices effects, but in the main the income effects are relatively small and hence the primary factor behind the welfare gains is the change in relative (consumer) prices – see Figures 16 and 17. However the consumer price changes differ appreciably between the small and large country cases – this is to be expected since the large country case is configured such that the exchange rate effect is largely nullified. Nevertheless the overall effect is positive in both cases.

**Figure 16: Selected Consumer Price Changes with Small Country Assumption (%)**

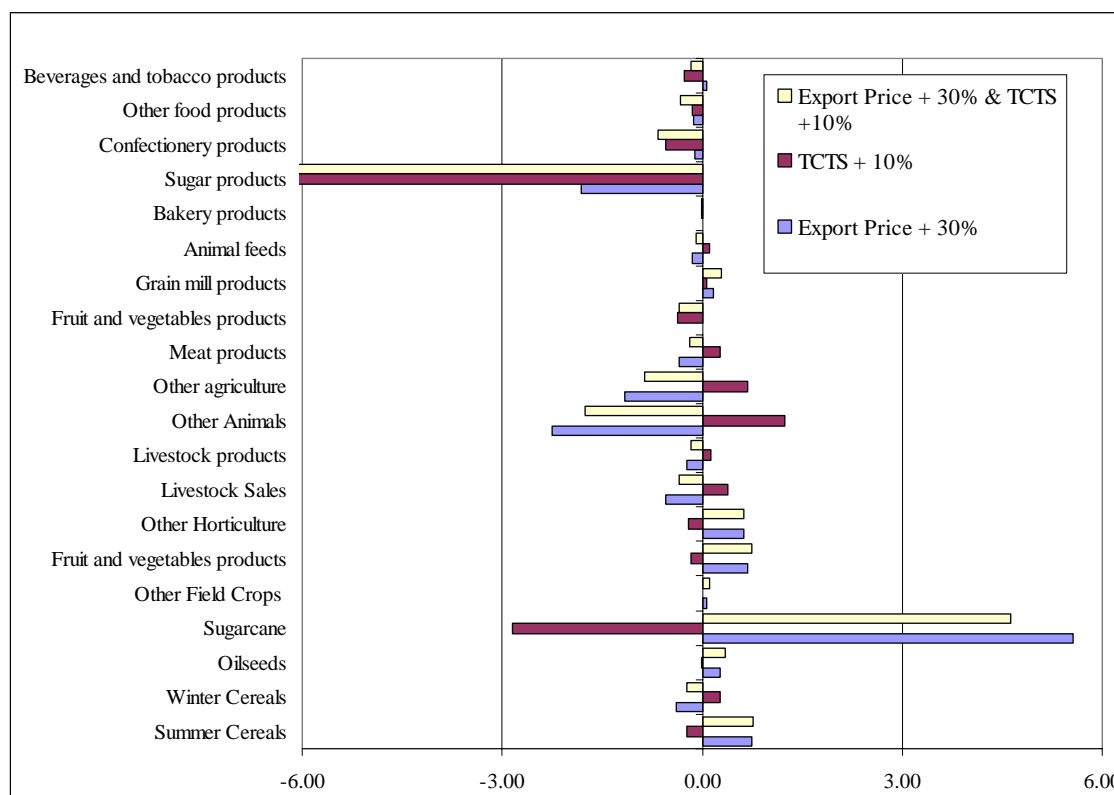

Source: Simulation results

**Figure 17: Selected Consumer Price Changes with Large Country Assumption (%)**

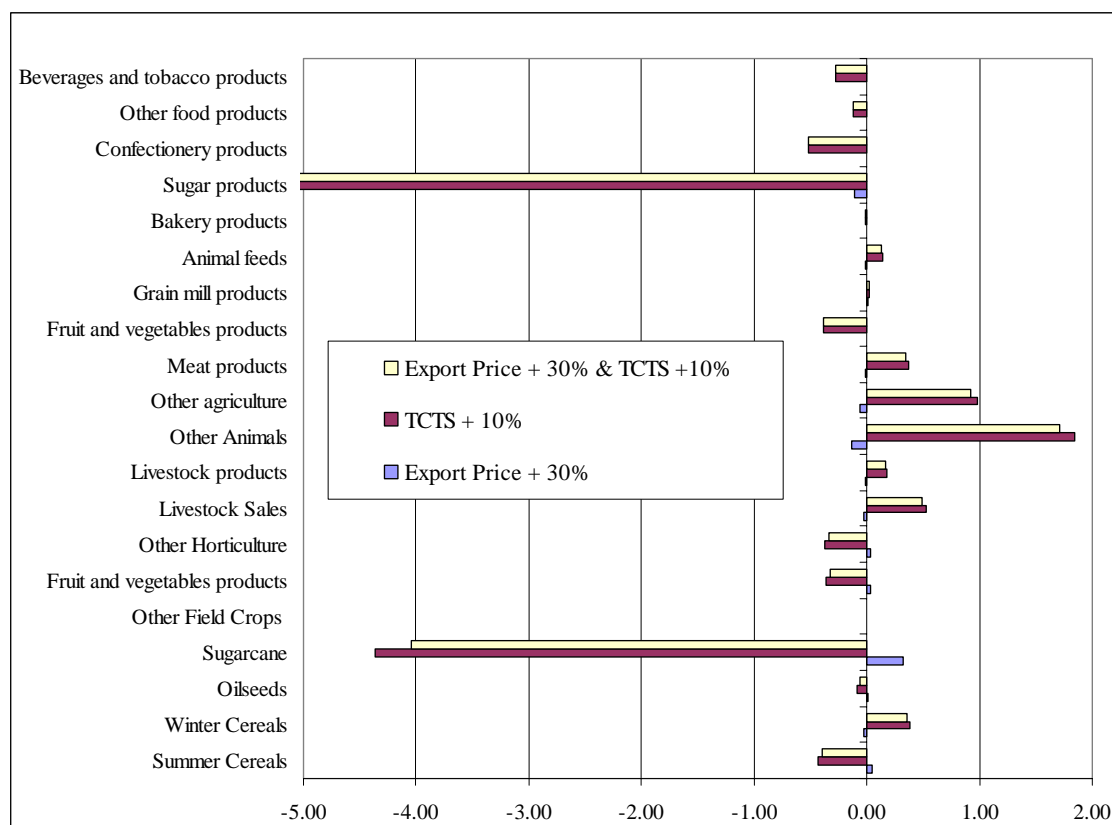

Source: Simulation results

## 5. Conclusions

The results in this study derive from the maintained assumption that global trade in sugar will be liberalised. In a market so characterised by market interventions, bilateral trade agreements, domestic support mechanisms and political positioning it is difficult to make a strong argument that trade liberalisation is imminent. However there is some evidence to suggest that the OECD countries are beginning to reduce the extent to which they intervene in sugar markets, e.g., the on-going downward reduction in the extent to which the EU's domestic prices exceed world prices, and hence that some liberalisation is likely to be seen over the next few years. Moreover, recent (mid 2004) WTO rulings about the EU's subsidies for sugar producers, especially with respect to the effects of subsidies associated with exports that match the preferential imports of sugar for the ACP (African, Caribbean and Pacific) group of countries suggest pressure to liberalise sugar trade may be growing more meaningful. Importantly the results from these analyses indicate that the benefits to South Africa from the liberalisation of global sugar trade may be appreciable and hence that there are substantial reasons for South Africa to argue for liberalisation both multilaterally, through the WTO, and

bilaterally in its negotiations with OECD trading partners. In the former case there is clearly an argument for further analyses using a global model to assist in the identification of South Africa's natural allies in multilateral negotiations.

The outcomes for South Africa of sugar trade liberalisation are not however unambiguously positive. While all the representative household groups, on average, gain under all the scenarios considered here there are likely to be some households that lose out. Predominately these are likely to be those households that are affected directly by the reorganisation of agricultural production across the different provinces of South Africa, with the negative effects being most concentrated in Gauteng, Mpumalanga and the North West. In some instances these negative consequences may be quite severe since they will be associated with job losses. On the other hand these negative effects seem to be more than offset by the positive effects that are most concentrated in KwaZulu-Natal, the Free State and Northern Cape.

A critical aspect of the results is the degree to which welfare gains can be realised through technical change. These results indicate that there are strong incentives from the consumers' perspective to foster improvements in the TCTS ratio despite the potentially negative consequences for producers of sugarcane. This begs two questions. First, can the South African sugar industry develop to such an extent that it can reduce the TCTS and second, how will changes in the structure of cane production, especially the move towards production on smaller family farms rather than large estates, affect the TCTS ratios. This latter is especially relevant to the land reform issue since there is some evidence that land under sugarcane production is particularly favoured for redistribution. These results suggest that land reform in the sugarcane growing areas needs to pay particular attention to the coordination of cane growing, cutting and milling to maintain the profitability of land reform farms.

## 6. References

- Armington, P.S., (1969). A theory of demand for products distinguished by place of production. IMF Staff Papers. Vol. 16.
- Commission of the European Communities (2003). "Reforming the European Union's sugar policy: Summary of impact assessment work", Commission staff working paper.
- Bates, R and P. Sokhela (2003). "The Development of Small-Scale Sugar Cane Growers: A Success Story?" In L. Nieuwoudt & J. Groenewald (eds), *The Challenge of Change: Agriculture, Land and the South African Economy*, University of Natal Press: Pietermaritzburg, South Africa, pp. 105-118.
- Beghin, J. C., and A. Aksoy. (2003). "Agricultural Trade and the Doha Round. Lessons from Commodity Studies". Paper prepared for the Annual World Bank Conference on Development Economics – Europe. Available online at: [www.worldbank.org/eurvp/web.nsf/Pages/Paper+by+Beghin/\\$File/BEGHIN.PDF](http://www.worldbank.org/eurvp/web.nsf/Pages/Paper+by+Beghin/$File/BEGHIN.PDF)

- Common Organisation of the Sugar Market: Description (2003) OECD Publication available online?
- Dervis, K., de Melo, J. and Robinson, S., (1982). *General Equilibrium Models for Development Policy*. Washington: World Bank.
- Devarajan, S., Lewis, J.D. and Robinson, S., (1994). *Getting the Model Right: The General Equilibrium Approach to Adjustment Policy*. Mimeo.
- Illovo Sugar (2004). Available online at [www.illovosugar.com/worldofsugar/index.htm](http://www.illovosugar.com/worldofsugar/index.htm)
- Kilkenny, M., (1991). 'Computable General Equilibrium Modeling of Agricultural Policies: Documentation of the 30-Sector FPGE GAMS Model of the United States', *USDA ERS Staff Report AGES 9125*.
- Matsebula, M. (2001). "Key Issues Facing Sugar Industries in the Southern African Development Community". Development Policy Research Unit, Working Paper Number 01/50, University of Cape Town.
- Malzbender, D. (2003). "Reforming the EU Sugar Regime: Will Southern Africa Still Feature?" Tralac Working Paper Number 12/2003.
- McDonald, S. and Walmsley, T., (2004). 'An Ex post Assessment of the EU South Africa Free Trade Agreement: The Welfare Costs of Excluding Commodities from the Agreement', *mimeo*.
- Mitchell, D., (2004). 'Sugar Policies: Opportunities for Change', *World Bank Policy Research WP 3222*. World Bank: Washington.
- PROVIDE (2004). 'A Social Accounting Matrix for South Africa: 2000'. *PROVIDE Technical Paper 2004:1*. Department of Agricultural Economics: Elsenburg. *Forthcoming*.
- PROVIDE (2003). 'Standard Computable General Equilibrium Model: Technical Documentation'. *PROVIDE Technical Paper 2003:3*. Department of Agricultural Economics: Elsenburg.
- Pursell, G., and A. Gupta. (1998). "Trade Policies and Incentives in Indian Agriculture: Methodology, Background Statistics and Protection and Incentive Indicators, 1965 –95. Background Paper No. 1: Sugar and Sugarcane". World Bank Working Paper Number 1953.
- Pyatt, G., (1988). 'A SAM Approach to Modeling', *Journal of Policy Modeling*, Vol 10, pp 327-352.
- Robinson, S., Kilkenny, M. and Hanson, K., (1990). 'USDA/ERS Computable General Equilibrium Model of the United States', *USDA ERS Staff Report AGES 9049*.
- South African Canegrowers' Association. Available online: [www.sacanegrowers.co.za](http://www.sacanegrowers.co.za)
- South African Sugar Association (2003). "South African Sugar Industry Directory" available online at: [www.sugar.org.za](http://www.sugar.org.za)
- USDA. (2003). South Africa Sugar Semi-Annual Report 2003, GAIN Report, Foreign Agricultural Service (FAS).

## 7. Appendix

Table 4: SAM Accounts for this Study

GAMS Name	Description	GAMS Name	Description	GAMS Name	Description
CSCER	Summer Cereals	AGWC	Western Cape	GOS	Gross operating surplus
CWCER	Winter Cereals	AGNC	Northern Cape	LND	Land
COSEED	Oilseeds	AGNW	North West	AFSKIL	African skilled labour
CSCANE	Sugarcane	AGFS	Free State	AFUSKIL	African unskilled labour
COFIELD	Other Field Crops	AGEC	Eastern Cape	AFMAN	African manual labour
CPOTVEG	Fruit and vegetables products	AGKZ	Kwazulu-Natal	COSKIL	Coloured skilled labour
COHORT	Other Horticulture	AGMP	Mpumalanga	COUSKIL	Coloured unskilled labour
CLSTOC	Livestock Sales	AGLP	Limpopo 1	COMAN	Coloured manual labour
CLPROD	Livestock products	AGGT	Gauteng	ASSKIL	Asian skilled labour
COANIM	Other Animals	AMINES	Other mining	ASUSKIL	Asian unskilled labour
CAGOTHER	Other agriculture	AMEATA	Meat	ASMAN	Asian manual labour
CMINES	Mining	AFRUITA	Fruit	WHSKIL	White skilled labour
CMEATA	Meat products	AOILSA	Oils and dairy	WHUSKIL	White unskilled labour
CFRUITA	Fruit and vegetables products	AGRAINA	Grainmills	WHMAN	White manual labour
COILSA	Oils fats and dairyproducts	AAFEEDA	Animal feeds	HAFUL	African urban low
CGRAINA	Grain mill products	ABAKEA	Bakeries	HAFUH	African urban high
CAFEEDA	Animal feeds	ASUGAR	Sugar	HAFRL	African rural low
CBAKEA	Bakery products	ACONFEC	Confectionery	HAFRH	African rural high
CSUGAR	Sugar products	AFOODA	Otherfood	HCOUL	Coloured urban low
CCONFEC	Confectionery products	ABEVTA	Beverages & tobacco	HCOUH	Coloured urban high
CFOODA	Other food products	ATEXTIL	Textile and leather products	HCORL	Coloured rural low
CBEVTA	Beverages and tobacco products	AWPAP	Wood and Paper	HCORH	Coloured rural high
CTEXTIL	Textile and leather products	ACHEM	Chemical Products	HASRL	Asian low
CWPAP	Wood and Paper	ARUBPL	Rubber and Plastic	HASRH	Asian high
CCHEM	Chemical Products	ANONMET	Non metal products	HWHUL	White urban low
CRUBPL	Rubber and Plastic	AMETAL	Metal products	HWHUH	White urban high
CNONMET	Non metal products	AMACH	Machinery	HWHRL	White rural low
CMETAL	Metal products	AELMACH	Electrical machines	HWHRH	White rural high
CMACH	Machinery	AVEHIC	Vehicles	IMPTAX	Import duties
CELMACH	Electrical machines	AMISC	Miscellaneous manufactures	EXPTAX	Export taxes
CVEHIC	Vehicles	AUTIL	Utilities	SALTAX	Sales taxes
CMISC	Miscellaneous manufactures	ACONSTR	Construction	INDTAX	Production taxes
CUTIL	Utilities	ATRADE	Trade	FACTTAX	Factor taxes
CCONSTR	Construction	ATRANS	Transport services	DIRTAX	Direct income taxes
CTRADE	Trade services	ASERV	Other services	GOVT	Government
CTRANS	Transport services	AGOVT	Government services	ENT	Enterprises
CSERV	Other services	ADSERV	Domestic Services	KAP	Savings
CGOVT	Government services			DSTOC	Stock Changes
CDSERV	Domestic Services			ROW	Rest of World
				TOTAL	Account Totals

**Working Papers in this Series**

<b>Number</b>	<b>Title</b>	<b>Date</b>
WP2004: 1	Trade Liberalisation, Efficiency, and South Africa's Sugar Industry	July 2004
WP2004: 2	The Impact of Oil Price Increases in the South African Economy	December 2004
WP2004: 3	The Welfare Impacts of Domestic and International Agricultural Efficiency Gains: A South African Case Study	December 2004

**Other PROVIDE Publications**

Technical Paper Series

Working Paper Series

Research Reports